Categories for the practising physicist

Bob Coecke¹ and Éric Oliver Paquette²

¹ OUCL, University of Oxford Bob.Coecke@comlab.ox.ac.uk

² DIRO, Université de Montréal eopaquette@inexistant.net

Summary. In this chapter we survey some particular topics in category theory in a somewhat unconventional manner. Our main focus will be on monoidal categories, mainly symmetric ones, for which we propose a physical interpretation. Special attention is given to the category of sets and relations, posetal categories, diagrammatic calculi, strictification, compact categories, biproduct categories and abstract matrix calculi, internal structures, and topological quantum field theories. In our attempt to complement the existing literature we (on purpose) omitted some very basic topics for which we point to other available sources.

0 Prologue: cooking with vegetables

Consider a raw potato. Conveniently, we refer to it as A . Raw potato A admits several *states* e.g. ‘dirty’, ‘clean’, ‘skinned’, ... We usually don’t eat raw potatoes so we need to *process* A such that it becomes eatable. We refer to this cooked version of A as B . Also B admits several states e.g. ‘boiled’, ‘fried’, ‘baked with skin’, ‘baked without skin’, ... Correspondingly, there are several ways to turn raw potato A into cooked potato B e.g. ‘boiling’, ‘frying’, ‘baking’, respectively referred to as f , f' and f'' . We make the fact that these cooking *processes* apply to raw potato A and produce cooked potato B explicit by *labelled arrows*:

$$A \xrightarrow{f} B \quad A \xrightarrow{f'} B \quad A \xrightarrow{f''} B.$$

A plain cooked potato tastes a bit dull so we’d like to process it into ‘spiced cooked potato’ C . We refer to the *composite process* resulting from first ‘boiling’ $A \xrightarrow{f} B$ and then ‘salting’ $B \xrightarrow{g} C$ as

$$A \xrightarrow{g \circ f} C.$$

Note that this composite process *hides* the intermediate *type* B , that is, we conceive processes as monolithic entities: they encode into which output state

of type B an input state of type A is transformed, but not the details of the manner in which this is done. Refer to ‘doing nothing to vegetable X ’ as

$$X \xrightarrow{1_X} X.$$

Then obviously $1_Y \circ \xi = \xi \circ 1_X = \xi$ for all processes $X \xrightarrow{\xi} Y$.

Potato is only one type (= kind) of vegetable. There are other types e.g. carrot. We refer to a raw carrot as D . It is indeed very important to distinguish our potato and our carrot explicitly in terms of their respective name A and D , or any other vegetable such as lettuce L , since each of these not only taste different but (in general) also admits distinct ways of processing.

We will make carrot-potato mash. We refer to the fact that *both A and D* are involved as $A \otimes D$. Refer to ‘frying the carrot’ as $D \xrightarrow{h} E$. Then, by

$$A \otimes D \xrightarrow{f \otimes h} B \otimes E$$

we mean ‘boil the potato’ *while* ‘frying the carrot’. ‘Mashing our spiced cooked potato C and our spiced cooked carrot F ’ is referred to as

$$C \otimes F \xrightarrow{x} M.$$

The whole process from raw components A and D to ‘meal’ M is

$$A \otimes D \xrightarrow{f \otimes h} B \otimes E \xrightarrow{g \otimes k} C \otimes F \xrightarrow{x} M = A \otimes D \xrightarrow{x \circ (g \otimes k) \circ (f \otimes h)} M,$$

where ‘peppering the carrot’ is referred to as $E \xrightarrow{k} F$.

The two operations ‘and then’ (i.e. $- \circ -$) and ‘while’ (i.e. $- \otimes -$) which we have at our disposal are not totally independent but *interact* in a certain way. In particular, distinct recipes can yield the same meal. E.g.

$$(1_B \otimes h) \circ (f \otimes 1_D) = (f \otimes 1_E) \circ (1_A \otimes h), \quad (1)$$

that is, it makes no difference whether ‘we first boil the potato and then fry the carrot’, or, ‘first fry the carrot and then boil the potato’.

Eq.(1) is in fact a generally valid equational law for cooking vegetables. Of course, chefs usually do not perform computations involving this law since their ‘intuition’ sufficiently accounts for the content of eq.(1). But, if we were to teach an android how to become a chef, which would require it/him/her to reason about which receipts yield the same dish, then we would need to tell it/him/her explicitly about the laws governing *cooking processes* (= recipes).

There is in fact a more general law governing cooking processes, from which eq.(1) can be derived (a proof of this is in Proposition 2 below), namely,

$$(g \circ f) \otimes (k \circ h) = (g \otimes k) \circ (f \otimes h), \quad (2)$$

that is, ‘boiling the potato and then salting it, while, frying the carrot and then peppering it’, is equal to ‘boiling the potato while frying the carrot, and then, salting the potato while peppering the carrot’.

Eq.(2) is a *logical* statement. In particular, note the remarkable similarity, but at the same time also the essential difference, of eq.(2) with the well-known distributive law of *classical logic* which states that

$$A \text{ and } (B \text{ or } C) = (A \text{ and } B) \text{ or } (A \text{ and } C). \tag{3}$$

Our ‘intuition’ also accounts for this distributive law (as long as we are not dealing with very complicated situations). But again it needs to be explicitly taught to androids if we require them to perform logical reasoning. This distributive law is key to the resolution method which is the standard implementation of artificial reasoning in AI and robotics [55].

The (\circ, \otimes) -logic is a *logic of interaction*. It applies to cooking processes, physical processes, biological processes, logical processes (i.e. proofs), or computer processes (i.e. programs). *Monoidal categories*, the subject of this chapter, constitute the unifying mathematical theory of all these types of processes. The framework of monoidal categories enables to *model* and *axiomatise* (or ‘classify’) the extra structure which certain families of processes may have. For example, how quantum processes differ from classical processes, and how are cooking processes differ from computational processes.

In the remainder of this chapter we provide a formal tutorial on several kinds of monoidal categories that are relevant to physics. If you’d rather stick to the informal story of this prologue you might want to take a bite of [17, 18].³

We pointed to the fact that our intuition accounts for (\circ, \otimes) -logic. Wouldn’t it be nice if there would be mathematical structures which also ‘automatically’ (or ‘implicitly’) account for the logical mechanisms which we intuitively perform? These mathematical structures exists and are becoming more and more prominent in recent developments in mathematics, including in important ‘Fields Medal awarding areas’ such as algebraic topology and representation theory e.g. [50, and references therein]. It are pictures! By far ****the**** coolest thing about monoidal categories is that they admit a purely pictorial calculus, and these pictures automatically account for the logical mechanisms which we intuitively perform. In these pictures both sites of eq.(2) are:

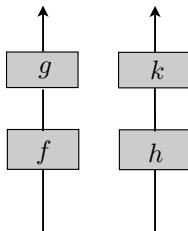

So eq.(2) becomes an implicit salient feature of the graphical calculus and needs no explicit attention anymore. This, as we will see below, substantially

³Paper [17] provided a conceptual template for setting up the content of this paper. However, here we go in more detail and provide more examples.

simplifies many computations. The differences between the two sites of eq.(2) can be recovered by introducing ‘artificial’ brackets within the two pictures:

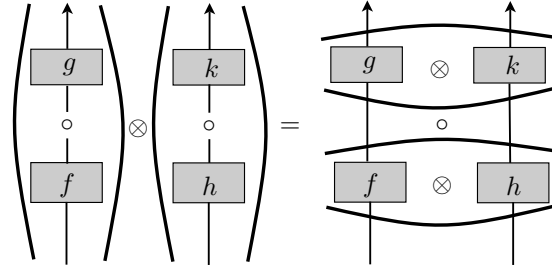

A detailed account on this graphical calculus is in Section 2.2.

That we do not give any serious attention to the subject of adjoints does not mean that we disagree with the fact that this is probably the greatest achievement of category theory thus far. Firstly, we do not consider ourselves to be by any means qualified to write on that. Secondly, adjoints are treated in great detail in the existing literature. The same goes for other important topics such as limits, monads [12] and n -categories [45]. What we tried to do here is to write a text we would have liked to have available at the time we started our own research in applications of category theory to physics. We in particular focused on categorical concepts with a direct physical interpretation and tried to present them in a way which complements the existing literature.

1 The 1D case: New arrows for your quiver

The core argument of the previous section involved the interaction of the two ways in which we can compose systems and operations: *sequentially* and *in parallel*, or more physically put, in time and in space. These are indeed the situations we truly care about. However, historically, category theoreticians cared mostly about *one-dimensional fragments* of the *two-dimensional* monoidal categories, simply called, *categories*.

Some people will get rebuked by the terminology and particular syntactic language used in category theory, which can sound and look like unintelligible jargon, resulting in its unfortunate label of *generalised abstract nonsense*. The reader should realise that initially category theory was crafted as ‘a theory of mathematical structures’. Hence substantial effort was made not to make any reference to the underlying *concrete models*, resulting in its seemingly idiosyncratic format. The personalities involved in crafting category theory, however brilliant minds they had, also did not always help the cause of making category theory accessible to a broader community.

But this ‘theory of mathematical structures’ view is not the only way to conceive category theory. As we argued above, and as is witnessed by its important use in computer science, in proof theory, and more recently also in

quantum informatics and in quantum foundations, category theory is a theory which brings the notion of *type* and *process* to the forefront, two notions which are hard to cast within traditional monolithic mathematical structures.

We profoundly believe that the fact that the mainstream physics community has not yet acquired this types/process structure as a primal part of its theories is merely accidental, and temporary, ... and will soon change.

1.1 Categories

Definition 1. A *category* \mathbf{C} consists of

1. A family⁴ $|\mathbf{C}|$ of *objects*;
2. For any $A, B \in |\mathbf{C}|$, a set $\mathbf{C}(A, B)$ of *morphisms*, the so-called *hom-set*;
3. For any $A, B, C \in |\mathbf{C}|$, and any $f \in \mathbf{C}(A, B)$ and $g \in \mathbf{C}(B, C)$, a *composite* $g \circ f \in \mathbf{C}(A, C)$, i.e., for all $A, B, C \in |\mathbf{C}|$ there is a *composition operation*

$$- \circ - : \mathbf{C}(A, B) \times \mathbf{C}(B, C) \rightarrow \mathbf{C}(A, C) :: (f, g) \mapsto g \circ f,$$

and this composition operation is *associative* and has *units*, that is,

- i. For any $f \in \mathbf{C}(A, B)$, $g \in \mathbf{C}(B, C)$ and $h \in \mathbf{C}(C, D)$ we have

$$h \circ (g \circ f) = (h \circ g) \circ f;$$

- ii. For any $A \in |\mathbf{C}|$, there exists a morphism $1_A \in \mathbf{C}(A, A)$ called *identity*, which is such that for any $f \in \mathbf{C}(A, B)$ we have

$$f = f \circ 1_A = 1_B \circ f.$$

A shorthand for $f \in \mathbf{C}(A, B)$ is $A \xrightarrow{f} B$. As already mentioned above, this definition was proposed by Samuel Eilenberg and Saunders Mac Lane in 1945 as part of a framework which intended to unify a variety of mathematical constructions within different areas of mathematics [30]. Consequently, most of the examples of categories that one encounters in the literature encode mathematical structures: the objects will be examples of this mathematical structure and the morphisms will be the *structure-preserving* maps between these. This kind of categories is usually referred to as *concrete categories* [5]. We also call them *concrete categorical models*.

1.2 Concrete categories

Traditionally, mathematical structures are defined as a set equipped with some operations, and some axioms, for instance:

⁴Typically, ‘family’ will mean a class rather than a set. While for many constructions the *size* of $|\mathbf{C}|$ is important, it will not play a key role in this paper.

- A *group* is a set G together with an associative binary operation

$$- \bullet - : G \times G \rightarrow G$$

with a two-sided identity 1 and where each element is invertible.

Similarly we define rings, fields and similar structures. Slightly more involved but still very much in the same spirit:

- A *vector space* is a pair (V, \mathbb{K}) of sets, respectively a commutative group and a field, which interact via the notion of scalar multiplication, that is, a mapping $V \times \mathbb{K} \rightarrow V$, which is also subject to some axioms.

Since the key structural data of a category is its composition, emphasis is given to the structure preserving maps rather than the structures themselves. Indeed, categorical structure neglects the structure of the objects themselves, which can be taken as a mere set of *labels* or *types*. Of course, for well-chosen notions of structure preservice, this ‘underlying’ structure is completely reflected within the compositional structure of the morphisms.

Examples of structure preserving functions are:

- *Group homomorphisms* i.e. functions which preserve $- \bullet -$ and 1 ;
- *Linear maps* i.e. functions which preserve linear combinations of vectors.

Example 1. Let **Set** be the concrete category with:

1. all sets as objects,
2. all functions between sets as morphisms,
3. ordinary composition of functions, that is, for $f : X \rightarrow Y$ and $g : Y \rightarrow Z$ we set $(g \circ f)(x) := g(f(x))$ for the composite $g \circ f : X \rightarrow Z$, and,
4. the obvious identities i.e. $1_X(x) := x$.

Set is indeed category since we have that:

- function composition is associative, and,
- for any function $f : X \rightarrow Y$ we have $(1_Y \circ f)(x) = f(x) = (f \circ 1_X)(x)$.

Example 2. **FdVect $_{\mathbb{K}}$** is the concrete category with:

1. finite dimensional vectors spaces over \mathbb{K} as objects,
2. all linear maps between these vectors spaces as morphisms, and
3. ordinary function composition –which yields a linear map when composing two linear maps– and identity functions –which are indeed linear functions.

Example 3 (elements). We are still able to single out elements within the objects. For the set $X \in |\mathbf{Set}|$ and some chosen element $x \in X$ the function

$$e_x : \{*\} \rightarrow X :: * \mapsto x,$$

where $\{*\}$ is any one-element set, maps the unique element of $\{*\}$ onto the chosen element x . If X contains n elements, there are n such functions each

corresponding to the element on which $*$ is mapped. Hence the elements of the set X are now encoded as the set $\mathbf{Set}(\{*\}, X)$.

In a similar manner we can single out vectors in vector spaces. For the vector space $V \in |\mathbf{FdVect}_{\mathbb{K}}|$ and some fixed vector $v \in V$ the linear map

$$e_v : \mathbb{K} \rightarrow V :: 1 \mapsto v,$$

where \mathbb{K} is now the one-dimensional vector space over itself, maps the element $1 \in \mathbb{K}$ onto the chosen element v . Since e_v is linear it is completely characterised by the image of the single element 1 , since

$$e_v(\alpha) = e_v(\alpha \cdot 1) = \alpha \cdot e_v(1) = \alpha \cdot v,$$

that is, the element 1 is a base for the one-dimensional vector space \mathbb{K} .

Example 4. **Grp** is the concrete category with:

1. all groups as objects,
2. group homomorphisms between these groups as morphisms, and,
3. ordinary function composition and identity functions.

Example 5. **Pos** is the concrete category with:

1. all partially ordered sets, that is, a set together with a reflexive, anti-symmetric and transitive relation, as objects,
2. order preserving maps, i.e. $x \leq y \Rightarrow f(x) \leq f(y)$, as morphisms, and,
3. ordinary function composition and identity functions.

An extended version of this category is **Pre** where we consider arbitrary pre-ordered sets, that is, a set together with a reflexive and transitive relation.

Example 6. **Cat** is the concrete category with:⁵

1. all categories as objects,
2. so-called *functors* between these as morphisms (see Section 1.6), and,
3. functor composition and identity functors.

1.3 Real world categories

But viewing category theory as some kind of *metatheory about mathematical structure* is not necessarily the most useful perspective for the sort of applications that we have in mind. Here are a few examples of the kind of categories we truly care about, and which are not categories with mathematical structures as objects and structure preserving maps as morphisms.

Example 7. The category **PhysProc** with

⁵In order to conceive **Cat** as a concrete category, the family of objects should be restricted to the so-called “small” categories i.e., categories for which the family of objects is a set.

1. all physical systems A, B, C, \dots as objects,
2. all processes which take a physical system of type A into a physical system of type B as the morphisms of type $A \longrightarrow B$ –these processes typically require some finite amount of time to be completed–, and,
3. sequential composition of these processes as composition and the processes which leave the system invariant as identities.

Note that associativity of composition is in this case completely trivial: if we first have process f , then process g , and then process h , it really doesn't matter whether we consider $(g \circ f)$ or $(h \circ g)$ as a single entity. All this is just superfluous data.

Example 8. The category **PhysOpp** is an *operational variant* of the above where rather than general physical systems such as stars we focus on systems which can be manipulated in the lab, and rather than general processes we consider the operations which the practising experimenter performs on these systems, e.g. applying force-fields, performing measurements etc.

Example 9. The category **QuantOpp** is a restriction of the above where we restrict ourselves to quantum systems and operations thereon. Special processes in **QuantOpp** are *preparation procedures*, or *states*. If Q denotes a qubit then the type of a preparation procedure would be $I \longrightarrow Q$ where I stands for ‘unspecified’. Indeed, the point of a preparation procedure is to provide a qubit in a certain state, and the resources which we use to produce that state are typically not of relevance for the remainder of the experimental procedure. We can further specialise to either pure (or closed) quantum systems or mixed (or open) quantum systems, categories to which we respectively refer as **PurQuantOpp** and **MixQuantOpp**.

Obviously, Example 9 is related to the concrete category which has Hilbert spaces as objects and certain types of linear mappings (e.g. CPM's) as morphisms. The preparation procedures discussed above then correspond with elements in the sense of Example 3. We discuss this correspondence below.

While to the sceptical reader the above examples still might not seem very useful yet, the next two ones, which are very similar, have become really important respectively for Computer Science and Logic.⁶

Example 10. The category **Comp** with

1. all data types, e.g. Booleans, integers, reals, as objects,
2. all programs which take data of type A as their input and produce data of type B as their output as the morphisms of type $A \longrightarrow B$, and,
3. sequential composition of programs as composition and the programs which output their input unaltered as identities.

⁶They are the reason that, for example, the Computing Laboratory at University of Oxford offers category theory to its undergraduates.

Example 11. The category **Prf** with

1. all propositions as objects,
2. all proofs which conclude from proposition A that proposition B holds as the morphisms of type $A \longrightarrow B$, and,
3. concatenation (or chaining) of proofs as composition and the tautologies ‘from A follows A ’ as identities.

Computer scientists particularly like category theory because it explicitly introduces the notion of *type*: an arrow $A \xrightarrow{f} B$ has type $A \longrightarrow B$. These types prevent silly mistakes when writing programs, e.g. the composition $g' \circ f$ makes no sense for $g' : C \rightarrow D$ because the output *–codomain–* of f doesn’t match the input *–domain–* of g' . Computer scientists would say:

“types don’t match”.

Similar categories **BioProc** and **ChemProc** can be build for organisms and biological processes, chemicals and chemical reactions, etc.⁷ The recipe for producing these categories is obvious:

Name	Objects	Morphisms
some area of science	corresponding systems	corresponding processes

Composition boils down to ‘first f and then g happens’ and identities are just ‘nothing happens’. Somewhat more operationally put, composition is ‘first *do* f and then *do* g ’ and identities are just ‘*doing* nothing’.⁸

1.4 Abstract categorical structures and properties

One can treat categories as mathematical structures in their own right, just as groups and vector spaces are mathematical structures. In contrast with concrete categories, abstract categorical structures then arise by either endowing categories with more *structure* or by requiring them to satisfy certain *properties*.

Example 12. A *monoid* (M, \bullet, e) is a set together with a binary associative operation $\bullet : M \times M \rightarrow M$ which admits a unit *–one could say, a ‘group without inverses’*. Equivalently, we can define a monoid as a category **M** with

⁷The first time the 1st author heard about categories was in a Philosophy of Science course, given by a biologist specialised in population dynamics, who discussed the importance of category theory in the influential work of Robert Rosen [56].

⁸The reason for providing both the ‘objectivist’ (= passive) and ‘instrumentalist’ (= active) perspective is that we both want to appeal to the theoretical physics and the quantum information community. The first community typically doesn’t like instrumentalism since it just doesn’t seem to make sense in the context of theories such as cosmology; on the other hand, instrumentalism is as important to quantum informatics as it is to ordinary informatics. We leave it up to the reader to decide whether it should play a role in the interpretation of quantum theory.

a single object $*$. Indeed, it suffices to identify the elements of $\mathbf{M}(*, *)$ with those of M , the associative composition operation

$$- \circ - : \mathbf{M}(*, *) \times \mathbf{M}(*, *) \rightarrow \mathbf{M}(*, *)$$

with the associative monoid multiplication \bullet , and the identity $1_* : * \rightarrow *$ with the unit e . Dually, in any category \mathbf{C} , for any $A \in |\mathbf{C}|$, the set $\mathbf{C}(A, A)$ is always a monoid.

Definition 2. Two objects $A, B \in |\mathbf{C}|$ are *isomorphic* if there exists morphisms $f \in \mathbf{C}(A, B)$ and $g \in \mathbf{C}(B, A)$ such that $g \circ f = 1_A$ and $f \circ g = 1_B$. The morphism f is called an *isomorphism* and $f^{-1} := g$ the *inverse* to f .

The notion of isomorphism known to the reader is the set-theoretical one, namely permutation or bijection. Given functions $f : X \rightarrow Y$ and $g : Y \rightarrow X$ satisfying $g(f(x)) = x$ for all $x \in X$ and $f(g(y)) = y$ for all $y \in Y$ we have:

- $f(x_1) = f(x_2) \Rightarrow g(f(x_1)) = g(f(x_2)) \Rightarrow x_1 = x_2$ so f is injective, and,
- for all $y \in Y$, setting $x := g(y)$, we have $f(x) = y$ so f is surjective,

so f is indeed a bijection. Since the converse also holds the category-theoretical notion of isomorphism coincides in the concrete category **Set** with the notion of permutation/bijection. In all other concrete categories mentioned above this categorical notion of isomorphism also coincides with the usual one, that is, a structure preserving bijection.

Example 13. Since a group (G, \bullet, e) is a monoid with inverses it can now be equivalently defined as a category with one object in which each morphism has an inverse –or is an isomorphism. More generally, a *groupoid* is a category in which each morphism has an inverse. Groupoids are of key importance for homotopy theory [16]. The category **Bijec** which has sets as objects and bijections as morphisms is such a groupoid. So is **FdUnit** which has finite dimensional Hilbert spaces as objects and unitary operators as morphisms.

From this, we see that ‘groups’ provide an example of an abstract categorical structure. At the same time, all groups together, with structure preserving maps between them, constitute a concrete category. Still following? That categories allow several ways of representing mathematical structures might seem confusing at first, but it is a token of their versatility.

While monoids correspond to categories with only one object, with groups as a special case, pre-orders are categories with very few morphisms, with partially ordered sets as a special case.

Example 14. Any preordered set (P, \leq) can be seen as a category **P**:

- the elements of P are the objects of **P**,
- whenever $a \leq b$ for $a, b \in P$ then there is a single morphism of type $a \longrightarrow b$, that is, $\mathbf{P}(a, b)$ is a singleton, and, whenever $a \not\leq b$, then there is no morphism of type $a \longrightarrow b$, that is, $\mathbf{P}(a, b)$ is empty.

- whenever there is pair of morphisms of types $a \longrightarrow b$ and $b \longrightarrow c$ respectively, that is, whenever $a \leq b$ and $b \leq c$, transitivity of \leq guarantees existence of a unique morphism of type $a \longrightarrow c$, which we take to be the composite of the morphisms of type $a \longrightarrow b$ and $b \longrightarrow c$. Reflexivity guarantees the existence of a unique morphism of type $a \longrightarrow a$, which we take to be the identity on the object a .

Conversely, a category \mathbf{C} in which there is at most one morphism of any type, i.e. hom-sets are either singletons or empty, defines a preordered set:

- $|\mathbf{C}|$ are the elements of the preordered set, and,
- $A \leq B$ if and only if $\mathbf{C}(A, B)$ is non-empty.
- Since \mathbf{C} is a category, whenever there exists $f \in \mathbf{C}(A, B)$ and $g \in \mathbf{C}(B, C)$ then there exists $g \circ f \in \mathbf{C}(A, C)$, that is, also $\mathbf{C}(A, C)$ is non-empty. Hence $A \leq B$ and $B \leq C$ yields $A \leq C$. Since $1_A \in \mathbf{C}(A, A)$ we also have $A \leq A$.

So preordered sets constitute an abstract category: its defining property is that every hom-set contains at most one morphism. Such categories are sometimes called *thin categories*. Conversely, categories which non-trivial hom-sets are called *thick*. Partially ordered sets also constitute an abstract category, namely one in which:

- every hom-set contains at most one morphism ;
- whenever two objects are isomorphic then they must be equal.

This second condition imposes anti-symmetry on the partial order.

Let $\{*\}$ and \emptyset denote a singleton set and the empty set. Then for any set $A \in |\mathbf{Set}|$, the set $\mathbf{Set}(A, \{*\})$ of all functions of type $A \rightarrow \{*\}$ is itself a singleton, since there is only one function which maps all $a \in A$ unto $*$, the single element of $\{*\}$. This concept can be *dualised*. The set $\mathbf{Set}(\emptyset, A)$ of functions of type $\emptyset \rightarrow A$ is again a singleton consisting of the ‘empty function’. Due to these special properties which the objects $\{*\}$ and \emptyset enjoy in the category in \mathbf{Set} we respectively call them *terminal* and *initial* and for \mathbf{Set} . All this can be generalised to arbitrary categories as follows:

Definition 3. An object $\top \in |\mathbf{C}|$ is *terminal* in \mathbf{C} if, for any $A \in |\mathbf{C}|$, there is only one morphism of type $A \longrightarrow \top$. An object $\perp \in |\mathbf{C}|$ is *initial* in \mathbf{C} if, for any $A \in |\mathbf{C}|$, there is only one morphism of type $\perp \longrightarrow A$.

Proposition 1. *If a category \mathbf{C} has two initial objects then these must be isomorphic. The same property also holds for terminal objects.*

Indeed, let \perp and \perp' be two initial objects in \mathbf{C} , then $\mathbf{C}(\perp, \perp')$ consists of a unique morphism f as \perp' is initial, while $\mathbf{C}(\perp', \perp) = \{g\}$ as \perp is also initial. Moreover, as \mathbf{C} is a category, $g \circ f$ is defined and in $\mathbf{C}(\perp, \perp) = \{1_\perp\}$ as again, \perp is initial and \mathbf{C} is a category. It follows that f is an isomorphism with $g = f^{-1}$ and that $\perp \simeq \perp'$ as claimed. Similarly $\top \simeq \top'$ is shown.

Example 15. A partially ordered set P is *bounded* if there exist two elements \top and \perp such that for all $a \in P$ we have $\perp \leq a \leq \top$. Hence, when P is viewed as a category, this means that it has both a terminal and an initial object.

The next example of an abstract categorical structure is the most important one in this paper. Therefore we state it as a definition. Among many (more important) things, it axiomatise ‘cooking with vegetables’.

Definition 4. A *strict monoidal category* is a category for which:

1. objects come with monoid structure $(|\mathbf{C}|, \otimes, \mathbf{I})$, that is, we have

$$A \otimes (B \otimes C) = (A \otimes B) \otimes C \quad \text{and} \quad \mathbf{I} \otimes A = A = A \otimes \mathbf{I},$$

2. for all objects $A, B, C, D \in |\mathbf{C}|$ there exists an operation

$$- \otimes - : \mathbf{C}(A, B) \times \mathbf{C}(C, D) \rightarrow \mathbf{C}(A \otimes C, B \otimes D) :: (f, g) \mapsto f \otimes g$$

which is associative and has $1_{\mathbf{I}}$ as its unit, that is,⁹

$$f \otimes (g \otimes h) = (f \otimes g) \otimes h \quad \text{and} \quad 1_{\mathbf{I}} \otimes f = f = f \otimes 1_{\mathbf{I}},$$

3. eq.(2) holds for all morphisms for which the types match, and, finally,
4. for all objects $A, B \in |\mathbf{C}|$ we have

$$1_A \otimes 1_B = 1_{A \otimes B}. \tag{4}$$

The two equational constraints eq.(2) and eq.(4) can be conceived as a single principle, as we shall see in Section 5.1. The categories of systems and processes discussed in Section 1.3 are all examples of strict monoidal categories. We already explained in Section 0 what $- \otimes -$ stands for: it enables to deal with situations where several systems are involved. To a certain extend $- \otimes -$ can be interpreted as a logical conjunction.

$$A \otimes B := \text{system } A \text{ and system } B$$

$$f \otimes g := \text{process } f \text{ and process } g.$$

There is however considerable care required with this view: while $A \wedge A = A$, we do not have $A \otimes A = A$ in general. This is where the so-called *linear logic* [33, 57] kicks in, which is discussed in substantial detail in [4, 29].

For the special object \mathbf{I} we have $A \otimes \mathbf{I} = A = \mathbf{I} \otimes A$ since it is the unit for the monoid. Hence it refers to a system which leaves any system invariant when we adjoin it to it, that is, ‘unspecified’, or, ‘no system’, or, ‘nothing’. We already made reference to it in Example 9 when discussing preparation procedures. Similarly, $1_{\mathbf{I}}$ is the operation which ‘does nothing to nothing’. It does make a lot of sense to have this silly system and operations in our theory: they will allow us to encode a notion of state within arbitrary monoidal categories, and also a notion of number and probabilistic weight –see below.

⁹Note that this operation on morphisms is a *typed* variant of the notion of monoid.

Example 16. A monoid (M, \bullet, e) can now also be conceived as a strict monoidal category in which all morphisms are identities. Indeed, take M to be the objects, \bullet to be the tensor and e to be the unit for the tensor. By taking identities to be the only morphisms we can equip these with the same monoid structure, hence satisfying eq.(4). By

$$(1_A \circ 1_A) \otimes (1_B \circ 1_B) = 1_A \otimes 1_B = 1_{A \otimes B} = 1_{A \otimes B} \circ 1_{A \otimes B} = (1_A \otimes 1_B) \circ (1_A \otimes 1_B)$$

also eq.(2) is satisfied.

1.5 Categories in physics

In the previous section we saw how groups and partial orders, both of massive importance for physics, are themselves abstract categorical structures.

- While there is no need to argue for the importance of group theory to physics here, it is worth mentioning that John Slater (cf. Slater determinant in quantum chemistry) referred to Weyl, Wigner and others’ use of group theory in quantum physics as *der Gruppenpest*, what translates as the ‘plague of groups’. He wrote, even still in 1975: “As soon as [my] paper became known, it was obvious that a great many other physicists were as disgusted as I had been with the group-theoretical approach to the problem. As I heard later, there were remarks made such as ‘Slater has slain the Gruppenpest’. I believe that no other piece of work I have done was so universally popular.” On which planet does this guy live? Similarly, in the case of category theory, one could wonder who are the true aliens: category theoreticians or the mathematicians which strongly oppose its use.
- Partial orders embody spatio-temporal causal structure [53, 60]. Roughly speaking, if $a \leq b$ then events a and b are causally related, if $a < b$ then they are time-like separated, and if a and b don’t compare then they are space-like separated. This theme is discussed in great detail in [46].

Also preorders play an important role e.g.:

- Also preorders play an important role e.g. they provide the only elegant and conclusive account on measuring quantum entanglement [49]. The relevant preorder is Muirhead’s majorization order [48]. An elegant conclusive account on multipartite entanglement as well as on mixed state entanglement is not available yet; we strongly believe that category theory provides the key to the solution in the following sense:

$$\frac{\text{bipartite entanglement}}{\text{some preorder}} = \frac{\text{multipartite entanglement}}{\text{some thick category}}$$

We also acknowledge the use of category theory in several involved subjects in mathematical physics ranging from topological quantum field theories (TQFTs) to proposals for a theory of quantum gravity; in many of these cases

the motivation to use category theory is of a more mathematical nature. We discuss one such topic, namely TQFT, in Section 5.5.

But the particular perspective which we would like to promote here is *categories as physical theories*. Above we discussed three kinds of categories:

- *Concrete categories* which have mathematical structures as objects and structure preserving maps between these as morphisms.
- *Real world categories* which have some notion of system as objects and corresponding processes thereof as morphisms.
- *Abstract categorical structures* are mathematical structures in their own right; they are categories defined in terms of additional structure and/or properties which they satisfy.

The real world categories constitute the *area* of our focus (e.g. quantum physics, proof theory, computation, organic chemistry, ...), the concrete categories constitute the formal mathematical *models* for these (e.g., in the case of quantum physics, Hilbert spaces as objects, certain types of linear maps as morphisms, and the tensor product as the monoidal structure), while the abstract categorical structures constitute *axiomatisations* of these.

The latter is obvious the place to start when one is interested in comparing theories: we can study which axioms and/or structural properties are responsible for certain behavioural properties of systems, e.g. non-local effects for quantum systems (e.g. [2]), or, we can study which structural features for example distinguish classical from quantum theories (e.g. [23, 22]). Quantum theory is subject to the so-called No-Cloning, No-Deleting and No-Broadcasting theorems [7, 51, 65], which impose key constraint on our capabilities to process quantum states. Expressing these clearly requires a formalism that allows to vary types, from a single to multiple systems, as well as one which accommodates processes (cf. copying/deleting process). Monoidal categories provide the appropriate mathematical arena for this –on-the-nose.

Example 17. Why does a tiger have stripes and a lion doesn't?



One strategy for finding an answer to this question would be to take a big knife and cut the tiger and the lion's belly open; maybe the explanation is hidden in the nature of the building blocks which these two animals are made up from. We find intestines but they seem to be very much the same in both cases. So maybe the answer is hidden in even smaller constituents. With a tiny knife we keep cutting and after a century of advancing 'small knife technology' we are able to identify a smaller kind of building block we now refer to as a

‘cell’. Again, no obvious difference for tigers and lions at this level. So we need to go even smaller, further advancing small knife technology, looking for the constituents of the cell, and bingo! We discover DNA and this constituent truly reveals the difference. So yes, now we know why tigers have stripes and lions don’t! Do we really? No, of course not. The real *explanation* for the fact that tigers have stripes and lions is a process of type

$$\text{prey} \otimes \text{predator} \otimes \text{environment} \longrightarrow \text{dead prey} \otimes \text{eating predator}$$

which represents the successful challenge of a predator, operating within a certain environment, on a certain prey, thanks to its camouflage. Lions hunt in sandy savanna while tigers hunt in the forest and it is relative to this environment that stripes happen to be adequate camouflage for tigers and plain sandy colours happen to be adequate camouflage for lions. The fact that these differences are encoded in their respective DNA is an evolutionary consequence of this, via the process of natural selection, and certainly not the cause. This example illustrates how monoidal categories enable to shift the focus from an *atomistic* or *reductionist* view on scientific theories to a more *interactive* view on scientific theories where systems are studied in terms of their interaction with other systems, rather than in terms of their constituents. Clearly in recent history physics has solely focused on chopping down things into smaller things. This approach, as it was the case for tigers and lions, might not give us a satisfactory understanding of the fundamental theories of nature.

1.6 Structure preserving maps for categories

The notion of structure preserving map between categories which we referred to in Example 6 wasn’t made explicit yet. These ‘maps which preserve categorical structure’, so-called *functors*, must preserve the *structure of the category*, that is, *composition* and *identities*. An example of a functor that might be known to the reader, because of its applications in physics, is the linear representation of a group. A representation of a group G on a vector space V is a group homomorphism from G to $\text{GL}(V)$, the general linear group on V , that is, a map $\rho : G \rightarrow \text{GL}(V)$ which is such that

$$\rho(g_1 \bullet g_2) = \rho(g_1) \circ \rho(g_2) \quad \text{for all } g_1, g_2 \in G, \quad \text{and,} \quad \rho(1) = 1_V.$$

Consider G as a category \mathbf{G} as in Example 13. We also have that $\text{GL}(V) \subset \mathbf{FdVect}_{\mathbb{K}}(V, V)$ (cf. Example 2). Hence, a group representation ρ from G to $\text{GL}(V)$ induces ‘something’ from \mathbf{G} to $\mathbf{FdVect}_{\mathbb{K}}$:

$$\rho : G \rightarrow \text{GL}(V) \quad \rightsquigarrow \quad \mathbf{G} \xrightarrow{R_\rho} \mathbf{FdVect}_{\mathbb{K}}.$$

However, specifying $\mathbf{G} \xrightarrow{R_\rho} \mathbf{FdVect}_{\mathbb{K}}$ requires some care:

- Firstly, we need to specify that we are representing on the general linear group of the vector space $V \in \mathbf{FdVect}_{\mathbb{K}}$. We do this by mapping the unique object $*$ of \mathbf{G} on V , thus defining a map from objects to objects

$$R_\rho : |\mathbf{G}| \rightarrow |\mathbf{FdVect}_{\mathbb{K}}| :: * \mapsto V.$$

- Secondly, we need to specify to which linear map in $\mathbf{FdVect}_{\mathbb{K}}(R_\rho(*), R_\rho(*)) = \text{GL}(R_\rho(*))$ a group element $g \in \mathbf{G}(*, *) = G$ is mapped. This defines a map from hom-set(s) to hom-set(s)

$$R_\rho : \mathbf{G}(*, *) \rightarrow \mathbf{FdVect}_{\mathbb{K}}(R_\rho(*), R_\rho(*)) :: g \mapsto \rho(g).$$

Since this mapping is a group homomorphism and we consider groups as a categories, it must preserve the composition and identities of these. Hence, it preserves the categorical structure.

Having this example in mind, we infer that a functor must consists not of a single but of *two* kinds of mappings, one map on the objects and a family of maps on the hom-sets which preserve identities and composition.

Definition 5. Let \mathbf{C} and \mathbf{D} be categories. A *functor* $F : \mathbf{C} \rightarrow \mathbf{D}$ consists of:

1. A mapping

$$F : |\mathbf{C}| \rightarrow |\mathbf{D}| :: A \mapsto F(A);$$

2. For any $A, B \in |\mathbf{C}|$, a mapping

$$F : \mathbf{C}(A, B) \rightarrow \mathbf{D}(F(A), F(B)) :: f \mapsto F(f)$$

which preserves identities and composition, that is,

- i. for any $f \in \mathbf{C}(A, B)$ and $g \in \mathbf{C}(B, C)$ we have

$$F(g \circ f) = F(g) \circ F(f),$$

- ii. and, for any $A \in |\mathbf{C}|$ we have

$$F(1_A) = 1_{F(A)}.$$

Typically one drops the parenthesis unless they are necessary. For instance, $F(A)$ and $F(f)$ will be denoted simply as FA and Ff . Consider the category **PhysProc** of Example 7 and a concrete category **Mod** (e.g. **FdHilb**) in which we wish to model these mathematically, by assigning to each process a morphism in the concrete category **Mod**. Functoriality of

$$F : \mathbf{PhysProc} \rightarrow \mathbf{Mod}$$

means that sequential composition of physical processes is mapped on composition of morphisms in **Mod** and that void processes are mapped on the identity morphisms. Hence functoriality is an obvious requirement when designing mathematical models for physical processes.

Example 18. Define the category $\mathbf{Mat}_{\mathbb{K}}$ with

1. the set of natural numbers \mathbb{N} as objects,
2. all $n \times m$ -matrices with entries in \mathbb{K} as morphisms of type $n \longrightarrow m$, and
3. matrix composition and identity matrices.

This example is closely related to Example 2. It however strongly emphasizes that objects are but labels with no internal structure. Strictly speaking this is not a concrete category in the sense of Section 1.2. However, for all practical purposes it can serve as well as a model as any concrete category. Therefore we relax our conception of concrete categories also to this kinds of model. Assume now that for each vector space $V \in |\mathbf{FdVect}_{\mathbb{K}}|$ we pick a fixed base. Then any linear function $f \in \mathbf{FdVect}_{\mathbb{K}}(V, W)$ admits a matrix in these bases. This ‘assigning of matrices’ to linear maps is described by the functor

$$F : \mathbf{FdVect}_{\mathbb{K}} \rightarrow \mathbf{Mat}_{\mathbb{K}}$$

which maps a vector space on its dimension and which maps a linear map on the matrix in the chosen bases. Note that it is not the category $\mathbf{FdVect}_{\mathbb{K}}$ but the functor F which encodes the choosing of bases.

Example 19. If in $\mathbf{Mat}_{\mathbb{C}}$ we map each natural number on itself and conjugate all the entries of each matrix then we also obtain a functor.

We now introduce the concept of *duality*, already hinted at above. Simply put, it means reversal of the arrows in a given category \mathbf{C} . We illustrate this operation by an example. Transposition of matrices:

- i. preserves identities,
- ii. reverses the direction of the morphisms since the matrix M^T has type $m \longrightarrow n$ whenever the matrix M has type $n \longrightarrow m$, and,
- iii. preserves the composition ‘up to’ this reversal of the arrows i.e.

$$(N \circ M)^T = M^T \circ N^T$$

for any pair of matrices N and M for which types match.

So transposition is a functor *up to* reversal of the arrows.

Definition 6. A *contravariant functor* $F : \mathbf{C} \rightarrow \mathbf{D}$ consists of the same data as a functors, also preserves identities, but reverses composition, that is,

$$F(g \circ f) = Ff \circ Fg,$$

Ordinary functors are often called *covariant functors*.

Definition 7. The *opposite category* \mathbf{C}^{op} of a category \mathbf{C} is the category with the same objects as \mathbf{C} but in with morphisms are reversed, that is,

$$f \in \mathbf{C}(A, B) \Leftrightarrow f \in \mathbf{C}^{op}(B, A),$$

–to avoid confusion we denote $f \in \mathbf{C}^{op}(B, A)$ by f^{op} and we call this morphism the *opposite* to f –, identities in \mathbf{C}^{op} are those of \mathbf{C} , and if $h = g \circ f$ in \mathbf{C} then $h^{op} = f^{op} \circ g^{op}$, that is,

$$f^{op} \circ g^{op} = (g \circ f)^{op}.$$

Contravariant functors of type $\mathbf{C} \rightarrow \mathbf{D}$ can now be defined as functors of type $\mathbf{C}^{op} \rightarrow \mathbf{D}$. Of course, the operation $(-)^{op}$ on categories is involutive: reversing the arrows twice is the same as doing nothing. The process of reversing the arrow is sometimes indicated by the prefix ‘co’ indicating that the defining equations for those structures are the same as the defining equations for the original structure but with arrows reversed.

Example 20. The *transpose* is the involutive contravariant functor

$$T : \mathbf{FdVect}_{\mathbb{K}}^{op} \rightarrow \mathbf{FdVect}_{\mathbb{K}}$$

which maps each vector space on the corresponding dual vector space and which maps each linear map f on its transpose f^T .

Example 21. Let \mathbf{FdHilb} be the category with finite dim. Hilbert spaces as objects, that is, finite dim. vector spaces over \mathbb{C} , for which an inner-product

$$\langle -, - \rangle : \mathcal{H} \times \mathcal{H} \rightarrow \mathbb{C}$$

is specified, and with all linear maps as morphisms. One could of course define other categories with Hilbert spaces as objects, for example, the groupoid \mathbf{FdUnit} of Example 13. But as we will see below in Section 2.3, the category \mathbf{FdHilb} as defined here comes with enough extra structure to extract all unitary maps from it. Hence, \mathbf{FdHilb} when endowed with that extra structure subsumes \mathbf{FdUnit} . This extra structure comes as a functor, namely, the *adjoint* or *hermitian transpose*. This is the contravariant functor

$$\dagger : \mathbf{FdHilb}^{op} \rightarrow \mathbf{FdHilb}$$

which:

1. is *identity-on-object*, that is,

$$\dagger : |\mathbf{FdHilb}|^{op} \rightarrow |\mathbf{FdHilb}| :: \mathcal{H} \mapsto \mathcal{H},$$

2. and assigns morphisms to their adjoints, that is,

$$\dagger : \mathbf{FdHilb}(\mathcal{H}, \mathcal{K}) \rightarrow \mathbf{FdHilb}(\mathcal{K}, \mathcal{H}) :: f \mapsto f^\dagger.$$

Since for $f \in \mathbf{FdHilb}(\mathcal{H}, \mathcal{K})$ and $g \in \mathbf{FdHilb}(\mathcal{K}, \mathcal{L})$ we have:

$$1_{\mathcal{H}}^\dagger = 1_{\mathcal{H}} \quad \text{and} \quad (g \circ f)^\dagger = f^\dagger \circ g^\dagger$$

we indeed obtain a contravariant functor, which is moreover involutive, that is, for all objects \mathcal{H} and all morphisms f we have

$$f^{\dagger\dagger} = f.$$

While the morphisms of **FdHilb** do not reflect the inner-product structure, the latter is required to specify the adjoint. In turns, this adjoint will allow us in Section 2.3 to recover the inner-product in purely category-theoretic terms.

Example 22. Define the category **Funct**_{C,D} with

1. all functors from **C** to **D** as objects,
2. *natural transformations* between these as morphisms (cf. Section 5.2), and,
3. composition of natural transformations and corresponding identities.

Example 23. The defining equations for strict monoidal categories, that is,

$$(g \circ f) \otimes (k \circ h) = (g \otimes k) \circ (f \otimes h) \quad \text{and} \quad 1_A \otimes 1_B = 1_{A \otimes B}, \quad (5)$$

which we refer to as *bifunctoriality*, is nothing but functoriality of a certain functor, as we shall see in Section 5.1.

Example 24. The TQFTs of Section 5.5 are special kinds of functors.

2 The 2D case: Muscle power

We now genuinely start to study the interaction of the parallel and the sequential modes of composing systems and operations thereon.

2.1 Strict symmetric monoidal categories

The starting point of this Section are the strict monoidal categories in Definition 4. They enable to give formal meaning to physical processes which involve several types, e.g. classical and quantum, as the following example clearly demonstrates.

Example 25. Define **CQOpp** to be the strict monoidal category containing both classical and quantum systems with operations thereon as morphisms and with the obvious notion of monoidal tensor, that is, analogous to how we introduced it for vegetables in the prologue. In this category non-destructive von Neumann measurements have type $Q \rightarrow X \otimes Q$ where Q is a quantum system and X is the classical data produced by the measurement. Obviously the hom-sets **CQOpp**(Q, Q) and **CQOpp**(X, X) have a very different structure since **CQOpp**(Q, Q) stands for the operations we can perform on a quantum system while **CQOpp**(X, X) stands for the classical operations (e.g. classical computations) which we can perform on classical systems. But all of these now live within a single mathematical entity **CQOpp**.

The structure of a strict monoidal category does not yet capture certain important properties of cooking with vegetables. Denote the strict monoidal category constructed in the Prologue by **Cook**.

Clearly ‘boil the potato while fry the carrot’ is very much the same thing as ‘fry the carrot while boil the potato’. But we cannot just bluntly say that $h \otimes f = f \otimes h$ in **Cook**. For this equation to even be meaningful the two morphisms $h \otimes f$ and $f \otimes h$ need to live in the same set, that is, respecting the structure of a category, within the same hom-set. So $A \otimes D \xrightarrow{f \otimes h} B \otimes F$ and $D \otimes A \xrightarrow{h \otimes f} F \otimes B$ need to have the same type which implies that $A \otimes D = D \otimes A$ and $B \otimes F = F \otimes B$ must hold. All this completely blurs the distinction between a carrot and a potato. For example, we cannot distinguish anymore between ‘boil the potato while fry the carrot’, which was

$$A \otimes D \xrightarrow{f \otimes h} B \otimes F,$$

or ‘fry the potato while boil the carrot’ which we now can write as

$$A \otimes D = D \otimes A \xrightarrow{h \otimes f} F \otimes B = B \otimes F.$$

The solution to this problem is to introduce an operation

$$\sigma_{A,D} : A \otimes D \rightarrow D \otimes A$$

which *swaps* the role of the potato and the carrot relative to the monoidal tensor. The fact that ‘boil the potato while fry the carrot’ is essentially the same thing as ‘fry the carrot while boil the potato’ can now be expressed as

$$\sigma_{B,E} \circ (f \otimes h) = (h \otimes f) \circ \sigma_{A,D}.$$

In this ‘real world example’ this operation can be interpreted as physically swapping the vegetables [18]. The equational law governing ‘swapping’ is:

$$\sigma_{B,A} \circ \sigma_{A,B} = 1_{A \otimes B}.$$

Definition 8. A *strict symmetric monoidal category* is a strict monoidal category **C** that also comes with a family of isomorphisms

$$\left\{ A \otimes B \xrightarrow{\sigma_{A,B}} B \otimes A \mid A, B \in |\mathbf{C}| \right\},$$

with $\sigma_{B,A}$ the inverse to $\sigma_{A,B}$ for all $A, B \in |\mathbf{C}|$, and which for all $A, B, C, D \in |\mathbf{C}|$ and all f, g of appropriate type satisfy

$$\sigma_{C,D} \circ (f \otimes g) = (g \otimes f) \circ \sigma_{A,B}. \quad (6)$$

We refer to these special morphisms as *symmetry*.

All Examples of Section 1.3 are strict symmetric monoidal categories for the obvious notion of symmetry in terms of ‘swapping’. We can rewrite eq.(6) in a more lucid form which makes the types explicit:

$$\begin{array}{ccc}
 A \otimes B & \xrightarrow{\sigma_{A,B}} & B \otimes A \\
 f \otimes g \downarrow & & \downarrow g \otimes f \\
 C \otimes D & \xrightarrow{\sigma_{C,D}} & D \otimes C
 \end{array} \tag{7}$$

This representation is referred to as *commutative diagrams*.

Proposition 2. *In any strict monoidal category we have*

$$\begin{array}{ccc}
 A \otimes B & \xrightarrow{1_A \otimes g} & A \otimes D \\
 f \otimes 1_B \downarrow & & \downarrow f \otimes 1_D \\
 C \otimes B & \xrightarrow{1_C \otimes g} & C \otimes D
 \end{array} \tag{8}$$

Indeed, relying on bifunctionality we have:

$$\begin{aligned}
 (f \otimes 1_D) \circ (1_A \otimes g) &= (f \circ 1_A) \otimes (1_D \circ g) \\
 &\parallel \\
 &f \otimes g \\
 &\parallel \\
 (1_B \circ f) \otimes (g \circ 1_C) &= (1_C \otimes g) \circ (f \otimes 1_B).
 \end{aligned}$$

The reader can easily verify that, given a connective $- \otimes -$ both on objects and morphisms as in items 1 & 2 of Definition 4, the four equations

$$(f \circ 1_A) \otimes (1_D \circ g) = f \otimes g = (1_B \circ f) \otimes (g \circ 1_C) \tag{9}$$

$$(g \otimes 1_D) \circ (f \otimes 1_B) = (g \circ f) \otimes 1_D \tag{10}$$

$$(1_D \otimes g) \circ (1_B \otimes f) = 1_D \otimes (g \circ f), \tag{11}$$

when varying over all object $A, B, C, D \in |\mathbf{C}|$ and all morphisms f and g of appropriate type, are equivalent to the single equation

$$(g \circ f) \otimes (k \circ h) = (g \otimes k) \circ (f \otimes h) \tag{12}$$

when varying over f, g, h, k . Eqs.(10,11) together with $1_A \otimes 1_B = 1_{A \otimes B}$ is usually referred to as $- \otimes -$ being *functorial in both arguments*. They are indeed equivalent to, for all objects $C \in |\mathbf{C}|$, the assignments

$$(- \otimes 1_C) : \mathbf{C} \rightarrow \mathbf{C} \quad \text{and} \quad (1_C \otimes -) : \mathbf{C} \rightarrow \mathbf{C},$$

both being functors –the action of objects of these functors is

$$(- \otimes 1_C) :: A \mapsto A \otimes C \quad \text{and} \quad (1_C \otimes -) :: A \mapsto C \otimes A.$$

2.2 Graphical calculus for symmetric monoidal categories

The most attractive and at the same time also the most powerful feature of strict symmetric monoidal categories is that they admit a purely diagrammatic calculus. Such a graphical language is subject to the following requirements:

- The symbolic ingredients in the definition of strict symmetric monoidal structure, or any other other abstract categorical structure which refines it, all have a purely diagrammatic counterpart;
- The corresponding axioms become very intuitive graphical manipulations;
- An equational statement is derivable in the graphical language if and only if it is symbolically derivable from the axioms of the theory.

For a more formal presentation of what we precisely mean by a graphical calculus we refer the reader to Peter Selinger’s paper [59] in these volumes. These diagrammatic calculi trace back to Penrose’s work in the early 1970s, and have been given rigorous formal treatments in [32, 35, 36, 58]. Some examples of possible elaborations and corresponding applications of the graphical language presented in this paper are in [21, 22, 20, 42, 59, 61, 63, 64].

The graphical counterparts to the axioms are typically much simpler than their formal counterparts. For example, in the Prologue we mentioned that bifunctionality becomes a tautology. Therefore such a graphical language radically simplifies algebraic manipulations and in many cases trivialises something very complicated. Also the physical interpretation of the axioms, something which is dear to the authors of this paper, becomes very direct.

The graphical counterparts to strict symmetric monoidal structure are:

- The *identity* 1_I is not depicted (= empty picture).
- The *identity* 1_A for and object A different of I is depicted as

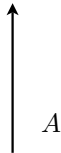

- A *morphism* $f : A \rightarrow B$ is depicted as

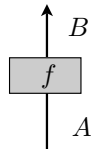

- The *composition* of morphisms $f : A \rightarrow B$ and $g : B \rightarrow C$ is depicted by locating g above f and by connecting the output of f to the input of g i.e.

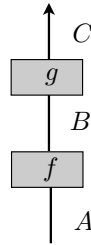

- The *tensor product* of morphisms $f : A \rightarrow B$ and $g : C \rightarrow D$ is depicted by aligning the graphical representation of f and g side by side in the order occurring within the expression $f \otimes g$ i.e.

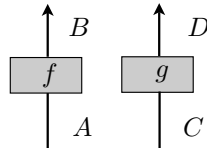

- *Symmetry* $\sigma_{AB} : A \otimes B \rightarrow B \otimes A$ is depicted as

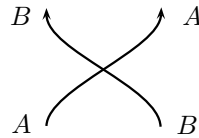

- Morphisms $\phi : I \rightarrow A$, $\pi : A \rightarrow I$, $s : I \rightarrow I$ are respectively depicted as

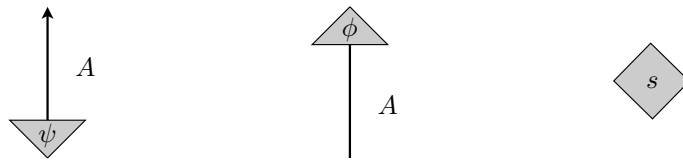

The diamond shape of the morphisms of type $I \rightarrow I$ indicates that they arise when composing two triangles:

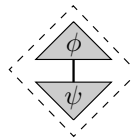

Example 26. In the category **QuantOpp** the triangles of respective types $I \rightarrow A$ and $A \rightarrow I$ represent states and effects, and the diamonds of type $I \rightarrow I$ can be interpreted as probabilistic weights: they give the likeliness of a certain effect to occur when the system is in a certain state. In the usual quantum formalism this corresponds to computing the Born rule or Luders' rule. In the

graphical language of appropriate categories we find these exact values back as one of these diamonds by composing a state and an effect [19, 59].

The equation

$$f \otimes g = (f \otimes 1_D) \circ (1_A \otimes g) = (1_B \otimes g) \circ (f \otimes 1_C) \quad (13)$$

established in Proposition 2 is depicted as:

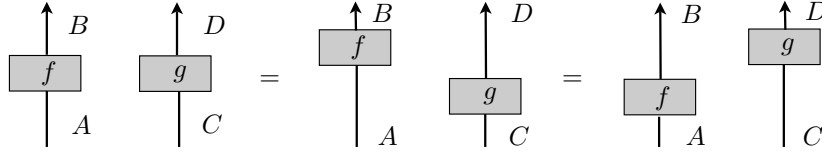

In words: we can ‘slide’ boxes along their wires. The first defining equation of symmetry, i.e. eq.(7), depicts as:

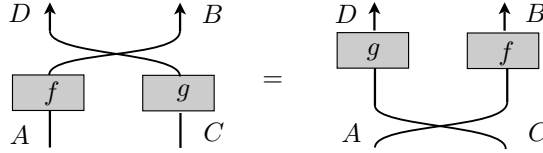

I.e. we can also ‘slide’ boxes along crossings of wires. Finally, the second defining equation of a strict symmetric monoidal category

$$\sigma_{B,A} \circ \sigma_{A,B} = 1_{A,B} \quad (14)$$

depicts as

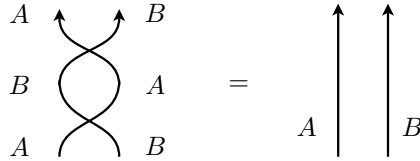

Suppose now that one intends to prove in any strict symmetric monoidal category that for three arbitrary morphisms $f : A \rightarrow A'$, $g : B \rightarrow B'$ and $h : C \rightarrow C'$ the equation

$$\begin{aligned} & (\sigma_{B',C'} \otimes f) \circ (g \otimes \sigma_{A,C'}) \circ (\sigma_{A,B} \otimes h) \\ &= (h \otimes \sigma_{A',B'}) \circ (\sigma_{A',C} \otimes 1_{B'}) \circ (1_{A'} \otimes \sigma_{B',C}) \circ (f \otimes g \otimes 1_C) \end{aligned}$$

always holds. Then, the typical textbook proof proceeds by *diagram chasing*:

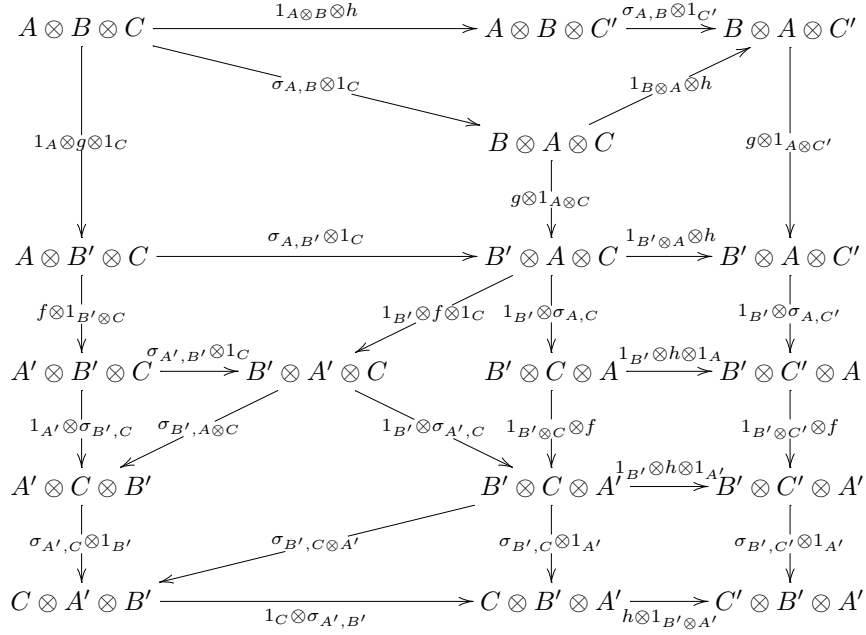

One needs to read this ‘monster’ as follows. The two outer paths both going from the left-upper-corner to the right-lower-corner represent the two sides of the equality we have to prove. Then we do what category-theoreticians call diagram chasing, that is, by ‘pasting’ together several commutative diagrams we try to pass from one of the outer paths to the other. For example, the triangle at the top of the diagram expresses that

$$(\sigma_{A,B} \otimes 1_{C'}) \circ (1_{A \otimes B} \otimes h) = (1_{B \otimes A} \otimes h) \circ (\sigma_{A,B} \otimes 1_C),$$

that is, an instance of bifactoriality. Using the properties of strict symmetric monoidal categories, that is, here, bifactoriality and eq.(7) expressed as commutative diagrams, we can pass from the outer path at the top and the right to the outer path on the left and the bottom. This a very tedious task and paper-writing becomes fairly unpleasant. On the other hand, graphically one immediately sees:

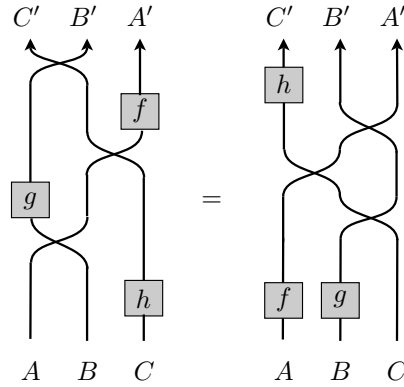

must hold. We pass from one picture to the other by sliding the boxes along wires, and by then rearranging these wires. In terms of the underlying equations of strict symmetric monoidal structure ‘sliding the boxes along wires’ uses eq.(7) and eq.(13), while ‘rearranging these wires’ means that we used again eq.(7) in the following manner:

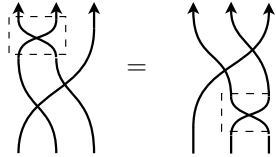

Indeed, since symmetry is a morphism like any other morphism, it can be conceived as a box and hence we can ‘slide it along wires’.

In a broader historical perspective we are somewhat unfair here. Writing equational reasoning down in terms of these commutative diagrams rather than long lists of equalities was an important step towards a better geometrical understanding of the structure of proofs.

2.3 Extended Dirac notation

Definition 9. A *strict dagger monoidal category* \mathbf{C} is a strict monoidal category which comes with an identity-on-objects contravariant involutive functor $\dagger : \mathbf{C}^{op} \longrightarrow \mathbf{C}$, that is, $A^\dagger = A$ for all objects A and $f^{\dagger\dagger} = f$ for all morphisms f , and which moreover satisfies

$$(f \otimes g)^\dagger = f^\dagger \otimes g^\dagger. \tag{15}$$

We will refer to $B \xrightarrow{f^\dagger} A$ as the *adjoint* to $A \xrightarrow{f} B$. A *strict dagger symmetric monoidal category* \mathbf{C} is both a strict dagger monoidal category and a strict symmetric monoidal category for which we have that

$$\sigma_{A,B}^\dagger = \sigma_{A,B}^{-1}.$$

Definition 10. [2] A morphism in a strict dagger monoidal category is called *unitary* if its inverse and its adjoint coincide. We define the *inner-product* of two ‘elements’ $\psi : I \longrightarrow A$ and $\phi : I \longrightarrow A$ of the same type in a strict dagger monoidal category to be the ‘scalar’

$$\langle \phi | \psi \rangle := \phi^\dagger \circ \psi : I \longrightarrow I.$$

In any strict monoidal category we indeed refer to morphisms of type $I \longrightarrow A$ as *elements* (cf. Exercise 3) and to those of type $I \longrightarrow I$ as *scalars*. To those of type $A \longrightarrow I$ we can refer as *co-elements*. As already discussed in Example 26 in the category **QuantOpp** these respectively correspond to states, probabilistic weights and effects.

Even at this abstract level many familiar things follow from Definition 10. For example, we recover the defining property of adjoints for any dagger:

$$\begin{aligned} \langle f^\dagger \circ \psi | \phi \rangle &= (f^\dagger \circ \psi)^\dagger \circ \phi \\ &= (\psi^\dagger \circ f) \circ \phi \\ &= \psi^\dagger \circ (f \circ \phi) \\ &= \langle \psi | f \circ \phi \rangle. \end{aligned}$$

From this it follows that unitary morphisms preserve the inner-product:

$$\begin{aligned} \langle U \circ \psi | U \circ \phi \rangle &= \langle U^\dagger \circ (U \circ \psi) | \phi \rangle \\ &= \langle (U^\dagger \circ U) \circ \psi | \phi \rangle \\ &= \langle \psi | \phi \rangle. \end{aligned}$$

The graphical calculus of the previous section extends to strict dagger symmetric monoidal categories. Following Selinger [59] we introduce an asymmetry in the graphical notation of the morphisms $A \xrightarrow{f} B$ as follows:

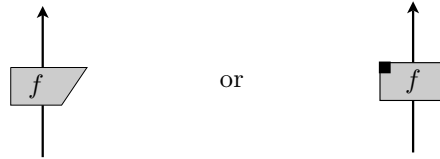

Then we depict the adjoint $A \xrightarrow{f^\dagger} B$ to $A \xrightarrow{f} B$ as follows

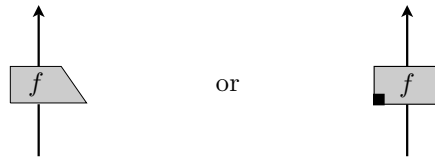

that is, we put the box representing f upside-down. All this enables interpretation of Dirac notation [27] in terms of strict dagger symmetric monoidal categories and in particular in terms of the corresponding graphical calculus:

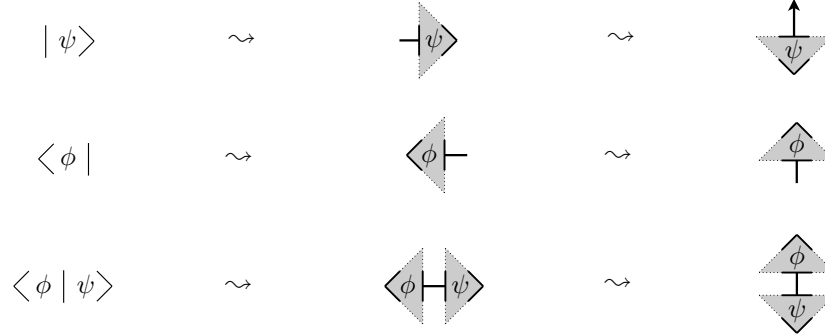

which merely requires closing the bra's and ket's and performing a 90° rotation.¹⁰ Summarising we now have:

Dirac	matrix	strict †-SMC	picture
$ \psi\rangle$	$\begin{pmatrix} \psi_1 \\ \vdots \\ \psi_n \end{pmatrix}$	$I \xrightarrow{\psi} A$	
$\langle\phi $	$(\bar{\phi}_1 \dots \bar{\phi}_n)$	$A \xrightarrow{\phi} I$	
$\langle\phi \psi\rangle$	$(\bar{\phi}_1 \dots \bar{\phi}_n) \begin{pmatrix} \psi_1 \\ \vdots \\ \psi_n \end{pmatrix}$	$I \xrightarrow{\psi} A \xrightarrow{\phi^\dagger} I$	
$ \psi\rangle\langle\phi $	$\begin{pmatrix} \psi_1 \\ \vdots \\ \psi_n \end{pmatrix} (\bar{\phi}_1 \dots \bar{\phi}_n)$	$A \xrightarrow{\phi^\dagger} I \xrightarrow{\psi} A$	

In particular, note that in the language of strict dagger symmetric monoidal categories both a bra-ket and a ket-bra are compositions of morphisms i.e. $\phi^\dagger \circ \psi$ and $\psi \circ \phi^\dagger$ respectively. What the diagrammatic calculus adds to all this is a second dimension to accommodate the monoidal composition:

¹⁰This 90° rotation is merely a consequence of our convention to read pictures from bottom-to-top. Other authors obey different conventions e.g. top-to-bottom or left-to-right reading.

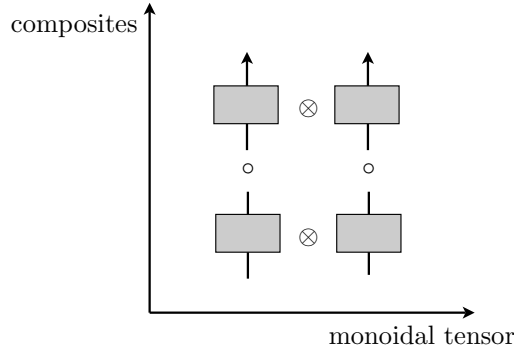

The advantages of this have already been made clear in the previous section and will even become clearer in Section 3.1.

In the light of the types of the morphisms in the third column of the above table, recall again that in Example 3 we showed that the vectors in Hilbert spaces \mathcal{H} can be faithfully represented by linear maps of type $\mathbb{C} \rightarrow \mathcal{H}$. Similarly, complex numbers $c \in \mathbb{C}$, that is, equivalently, vectors in the ‘one-dimensional Hilbert space \mathbb{C} , can be faithfully represented by linear maps

$$s_c : \mathbb{C} \rightarrow \mathbb{C} :: 1 \mapsto c$$

since by linearity the image of 1 fully specifies this map.

However, by making explicit reference to **FdHilb** and hence also by having matrices (that is, morphisms in **FdHilb** expressed relative to some bases) in the above table we are actually cheating. The fact that Hilbert spaces and linear maps are set-theory based mathematical structures has non-trivial ‘unpleasant’ implications. In particular, while the \otimes -notation for the monoidal structure of strict monoidal categories insinuates that the tensor product would turn **FdHilb** into a strict symmetric monoidal category, this turns out not to be true in the ‘strict’ sense of the word true.

2.4 The set-theoretic verdict on strictness

As outlined in Section 1.5 we ‘model’ real world categories in terms of concrete categories. While the real world categories *are* indeed strict monoidal categories their corresponding models typically *aren't*. What goes wrong is the following. For set-theory based mathematical structures such as groups, topological spaces, partial orders and vector spaces, neither

$$A \otimes (B \otimes C) = (A \otimes B) \otimes C \quad \text{nor} \quad I \otimes A = A = A \otimes I$$

hold. This is due to the fact that for the underlying sets X, Y, Z we have that $(x, (y, z)) \neq ((x, y), z)$ and $(* , x) \neq x \neq (x, *)$ so, as a consequence, neither

$$X \times (Y \times Z) = (X \times Y) \times Z \quad \text{nor} \quad \{*\} \times X = X = X \times \{*\}$$

hold. We do have something very closely related to this, namely

$$X \times (Y \times Z) \simeq (X \times Y) \times Z \quad \text{and} \quad \{*\} \times X \simeq X \simeq X \times \{*\}.$$

That is, we have *isomorphisms* rather than *strict* equations. On the other hand, these are not just ordinary isomorphisms but they are so-called *natural* isomorphisms. These natural isomorphisms are an instance of the more general *natural transformations* which we discuss in Section 5.2.¹¹ Meanwhile we introduce a restricted version of this general notion of natural transformations.

Consider a category \mathbf{C} for which the objects come with an operation

$$- \otimes - : |\mathbf{C}| \times |\mathbf{C}| \rightarrow |\mathbf{C}| :: (A, B) \mapsto A \otimes B \quad (16)$$

and that for all objects $A, B, C, D \in |\mathbf{C}|$ there also exists an operation

$$- \otimes - : \mathbf{C}(A, B) \times \mathbf{C}(C, D) \rightarrow \mathbf{C}(A \otimes C, B \otimes D) :: (f, g) \mapsto f \otimes g \quad (17)$$

on morphisms. Let

$$\Lambda(x_1, \dots, x_n, C_1, \dots, C_m) \quad \text{and} \quad \Xi(x_1, \dots, x_n, C_1, \dots, C_m)$$

be two well-formed expressions built from $- \otimes -$, brackets, variables x_1, \dots, x_n and constants $C_1, \dots, C_m \in |\mathbf{C}|$. Then a natural transformation is a family

$$\{\Lambda(A_1, \dots, A_n, C_1, \dots, C_m) \xrightarrow{\xi_{A_1, \dots, A_n}} \Xi(A_1, \dots, A_n, C_1, \dots, C_m) \mid A_1, \dots, A_n \in \mathbf{C}\}$$

of morphisms which are such that for all objects $A_1, \dots, A_n, B_1, \dots, B_n \in |\mathbf{C}|$ and all morphisms $A_1 \xrightarrow{f_1} B_1, \dots, A_n \xrightarrow{f_n} B_n$ we have:

$$\begin{array}{ccc} \Lambda(A_1, \dots, A_n, C_1, \dots, C_m) & \xrightarrow{\xi_{A_1, \dots, A_n}} & \Xi(A_1, \dots, A_n, C_1, \dots, C_m) \\ \downarrow \Lambda(f_1, \dots, f_n, 1_{C_1}, \dots, 1_{C_m}) & & \downarrow \Xi(f_1, \dots, f_n, 1_{C_1}, \dots, 1_{C_m}) \\ \Lambda(B_1, \dots, B_n, C_1, \dots, C_m) & \xrightarrow{\xi_{B_1, \dots, B_n}} & \Xi(B_1, \dots, B_n, C_1, \dots, C_m) \end{array}$$

A natural transformation is a *natural isomorphism* if all these morphisms ξ_{A_1, \dots, A_n} are isomorphisms in the sense of Definition 2.

Examples of such well-formed expressions are

$$x \otimes (y \otimes z) \quad \text{and} \quad (x \otimes y) \otimes z$$

¹¹Naturality is one of the most important concepts of formal category theory. In fact, in the founding paper [30] Eilenberg and MacLane argue that *their* main motivation for introducing the notion of a category is to introduce the notion of a functor, and that *their* main motivation for introducing the notion of a functor is to introduce the notion of a natural transformation.

and the corresponding constraint on the morphisms is

$$\begin{array}{ccc}
 A \otimes (B \otimes C) & \xrightarrow{\alpha_{A,B,C}} & (A \otimes B) \otimes C \\
 \downarrow f \otimes (g \otimes h) & & \downarrow (f \otimes g) \otimes h \\
 A' \otimes (B' \otimes C') & \xrightarrow{\alpha_{A',B',C'}} & (A' \otimes B') \otimes C'
 \end{array} \quad (18)$$

If diagram (18) commutes for all $A, B, C, A', B', C', f, g, h$ and the morphisms

$$\alpha := \{\alpha_{A,B,C} \mid A, B, C \in \mathbf{C}\}$$

are all isomorphisms the this natural isomorphism is called or *associativity*. Its name refers to the fact that this natural isomorphism embodies a *weakening* the strict associative law $A \otimes (B \otimes C) = (A \otimes B) \otimes C$. A better name would actually be *re-bracketing* since that is what it truly does: it is a morphism –which we like to think of as a *process*– which transforms type $A \otimes (B \otimes C)$ into type $(A \otimes B) \otimes C$. In other words, it provides a *formal witness* to the actual *processes of re-bracketing a mathematical expression*. The *naturality condition* in diagram (18) formally states that re-bracketing *commutes* with any triple of operations f, g, h we apply to the systems, and hence tells us that the process of re-bracketing *does not interfere* with non-trivial processes any f, g, h , almost as if it wasn't there.

Other important pairs of well-formed formal expressions are

$$x \quad \text{and} \quad c \otimes x \qquad x \quad \text{and} \quad x \otimes c$$

and, for I the constant object, the corresponding naturality constraint is

$$\begin{array}{ccc}
 A & \xrightarrow{\lambda_A} & A \otimes I \\
 \downarrow f & & \downarrow 1_I \otimes f \\
 B & \xrightarrow{\lambda_B} & I \otimes B
 \end{array}
 \qquad
 \begin{array}{ccc}
 A & \xrightarrow{\rho_A} & A \otimes I \\
 \downarrow f & & \downarrow f \otimes 1_I \\
 B & \xrightarrow{\rho_B} & B \otimes I
 \end{array} \quad (19)$$

The natural isomorphisms λ and ρ in diagrams (19) are called *left-* and *right unit*. In this case a better name would have been *left-* and *right introduction* since they are the process introducing a new object relative to an exiting one.

We encountered a fourth important example in Definition 8, namely

$$x \otimes y \quad \text{and} \quad y \otimes x,$$

for which diagram (7) is the naturality condition. The isomorphism σ is called *symmetry* but a better name could have been *exchange* or *swapping*.

Example 27. The category **Set** has associativity, left- and right unit and symmetry natural isomorphisms relative to the Cartesian product with the singleton set $\{*\}$ as the monoidal unit, and setting

$$f \times f' : X \times X' \rightarrow Y \times Y' :: (x, x') \mapsto (f(x), f'(x'))$$

for $f : X \rightarrow Y$ and $f' : X' \rightarrow Y'$, namely:

$$\alpha_{X,Y,Z} : X \times (Y \times Z) \rightarrow (X \times Y) \times Z :: (x, (y, z)) \mapsto ((x, y), z)$$

$$\lambda_X : X \rightarrow \{*\} \times X :: x \mapsto (*, x) \quad \rho_X : X \rightarrow X \times \{*\} :: x \mapsto (x, *)$$

$$\sigma_{X,Y} : X \times Y \rightarrow Y \times X :: (x, y) \mapsto (y, x)$$

for which one easily verifies that diagrams (18), (19), (7) all commute. Showing that bifactoriality holds is somewhat more tedious.

Definition 11. A *monoidal category* consists of the following data:

1. a category \mathbf{C} ;
2. an object $I \in |\mathbf{C}|$;
3. a *bifunctor* $-\otimes-$, that is, an operation both on objects and on morphisms as in prescriptions (16) and (17) above, which moreover satisfies

$$(g \circ f) \otimes (k \circ h) = (g \otimes k) \circ (f \otimes h) \quad \text{and} \quad 1_A \otimes 1_B = 1_{A \otimes B}$$

for all objects $A, B \in |\mathbf{C}|$ and all morphisms f, g, h, k of appropriate type;

4. three natural isomorphisms

$$\alpha = \{A \otimes (B \otimes C) \xrightarrow{\alpha_{A,B,C}} (A \otimes B) \otimes C \mid A, B, C \in |\mathbf{C}|\},$$

$$\lambda = \{A \xrightarrow{\lambda_A} I \otimes A \mid A \in |\mathbf{C}|\} \quad \text{and} \quad \rho = \{A \xrightarrow{\rho_A} A \otimes I \mid A \in |\mathbf{C}|\},$$

hence satisfying eq.(18) and eq.(19), and such that we also have

$$\begin{array}{ccc} A \otimes (B \otimes (C \otimes D)) & \xrightarrow{\alpha_-} & (A \otimes B) \otimes (C \otimes D) & \xrightarrow{\alpha_-} & ((A \otimes B) \otimes C) \otimes D & (20) \\ 1_A \otimes \alpha_- \downarrow & & & & \uparrow \alpha_- \otimes 1_D & \\ A \otimes ((B \otimes C) \otimes D) & \xrightarrow{\alpha_-} & & \xrightarrow{\alpha_-} & (A \otimes (B \otimes C)) \otimes D & \end{array}$$

for all $A, B, C, D \in |\mathbf{C}|$, and,

$$\begin{array}{ccc} A \otimes B & \xrightarrow{1_A \otimes \lambda_B} & A \otimes (I \otimes B) & (21) \\ & \searrow \rho_A \otimes 1_B & \downarrow \alpha_{A,I,B} & \\ & & (A \otimes I) \otimes B & \end{array}$$

for all $A, B \in |\mathbf{C}|$, and, finally,

$$\lambda_I = \rho_I. \quad (22)$$

A monoidal category is *symmetric* if there is a fourth natural isomorphism

$$\sigma = \{A \otimes B \xrightarrow{\sigma_{A,B}} B \otimes A \mid A, B \in |\mathbf{C}|\}$$

satisfying eq.(7), and such that we also have

$$\begin{array}{ccc} A \otimes B & \xrightarrow{\sigma_{A,B}} & B \otimes A \\ & \searrow 1_{A \otimes B} & \downarrow \sigma_{B,A} \\ & & A \otimes B \end{array} \quad (23)$$

for all $A, B \in |\mathbf{C}|$, and

$$\begin{array}{ccc} A & \xrightarrow{\lambda_A} & I \otimes A \\ & \searrow \rho_A & \downarrow \sigma_{I,A} \\ & & A \otimes I \end{array} \quad (24)$$

for all $A \in |\mathbf{C}|$, and

$$\begin{array}{ccccc} A \otimes (B \otimes C) & \xrightarrow{\alpha_-} & (A \otimes B) \otimes C & \xrightarrow{\sigma_{(A \otimes B), C}} & C \otimes (A \otimes B) \\ \downarrow 1_A \otimes \sigma_{B,C} & & & & \downarrow \alpha_- \\ A \otimes (C \otimes B) & \xrightarrow{\alpha_-} & (A \otimes C) \otimes B & \xrightarrow{\sigma_{A,B} \otimes 1_C} & (C \otimes A) \otimes B \end{array} \quad (25)$$

for all $A, B, C \in |\mathbf{C}|$.

The set-theoretic verdict on strictness is very hard!

The punishment is grave: a definition which stretches over two pages since we need to carry along associativity and unit natural isomorphisms, which, on top of that, are subject to a formal overdose of *coherence conditions*, that is, eqs.(20,21,22,23,25). They embody rules which should be obeyed when natural isomorphisms interact with each other, in addition to the naturality conditions which state how natural isomorphisms interact with other morphisms in the category. For example, eq.(24) tells us that if we introduce I on the left of A and then swap I and A then this should be the same as introducing I on the right of A . Eq.(24) tells us that the two ways of re-bracketing the four variable expressions involved should be the same.

The general idea behind these coherence conditions is the following: if there are two ways to go from formal expression $\Lambda(A_1, \dots, A_n, C_1, \dots, C_m)$ to formal expression $\Xi(A_1, \dots, A_n, C_1, \dots, C_m)$ by composing natural isomorphisms – including identities which trivially are natural isomorphisms for the formal expressions $\Lambda(A) = \Xi(A) = A$ – both with $- \otimes -$ and $- \circ -$ then these composites should be equal. The fact that eqs.(20,21,22,23,25) suffice for this purpose is the consequence of MacLane’s highly non-trivial coherence theorem

for symmetric monoidal categories [47] –otherwise things could have been even worse, potentially involving equations with an unbounded number of symbols.

Pffffffffffffffffffff . . .

. . . sometimes miracles do happen:

Theorem 1 (Strictification [47] p.257). *Any monoidal category \mathbf{C} is categorically equivalent, via a pair of strong monoidal functors $G : \mathbf{C} \longrightarrow \mathbf{D}$ and $F : \mathbf{D} \longrightarrow \mathbf{C}$, to a strict monoidal category \mathbf{D} .*

The definitions of categorical equivalence and strong monoidal functor can be found below in Section 5.3. In words, what this means is that for category-theoretic purposes arbitrary monoidal categories behave exactly the same as strict monoidal categories. In particular, the connexion between diagrammatic reasoning (incl. Dirac notation) and axiomatic reasoning for strict monoidal categories extends to arbitrary monoidal categories. The essence of the above theorem is that the unit and associativity isomorphisms are so well-behaved that they don't affect this correspondence. In graphical calculus the associativity natural isomorphisms becomes implicit when we write

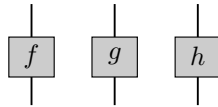

in that the absence of any brackets states that it does not matter whether we wish to interpret this picture either as:

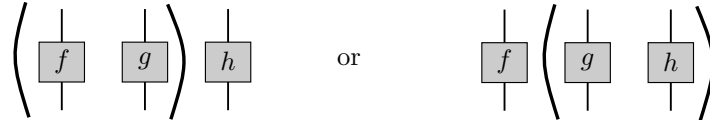

that is, whether in first order we want to associate f with g , and then in second order this pair as a whole with h , or whether in first order we want to associate g with h , and then in second order this pair as a whole with f .

So things turn out not to be not at all as bad as they looked at first sight!

Example 28. The category **Set** admits two important symmetric monoidal structures. We discussed the one provided by the Cartesian product in Example 27. The other one is provided by the *disjoint union*. Given two sets X and Y their disjoint union is the set

$$X + Y := \{(x, 1) \mid x \in X\} \cup \{(y, 2) \mid y \in Y\}.$$

This set can be thought of as the set of all elements both of X and Y , but where the elements of X are “coloured” with 1 while those of Y are “coloured” with 2. This guarantees that, when the same element occurs both in X and Y ,

it is twice accounted for in $X + Y$ since the “colours” 1 and 2 recall whether the elements in $X + Y$ either originated in X or in Y . As a consequence the intersection of $\{(x, 1) \mid x \in X\}$ and $\{(y, 2) \mid y \in Y\}$ is empty, hence the name ‘disjoint’ union. We take the empty set \emptyset as the monoidal unit and set

$$f + f' : X + X' \rightarrow Y + Y' :: \begin{cases} (x, 1) \mapsto (f(x), 1) \\ (x, 2) \mapsto (f'(x), 2) \end{cases}$$

for $f : X \rightarrow Y$ and $f' : X' \rightarrow Y'$. The natural isomorphisms of the symmetric monoidal structure are:

$$\alpha_{X,Y,Z} : X + (Y + Z) \rightarrow (X + Y) + Z :: \begin{cases} (x, 1) \mapsto ((x, 1), 1) \\ ((x, 1), 2) \mapsto ((x, 2), 1) \\ ((x, 2), 1) \mapsto (x, 2) \end{cases}$$

$$\lambda_X : X \rightarrow \emptyset + X :: x \mapsto (x, 2) \quad \rho_X : X \rightarrow X + \emptyset :: x \mapsto (x, 1)$$

$$\sigma_{X,Y} : X + Y \rightarrow Y + X :: (x, i) \mapsto (x, 3 - i)$$

for which one again easily verifies that diagrams (18), (19), (7) all commute. Showing that bifactoriality holds is again somewhat more tedious.

Example 29. The category $\mathbf{FdVect}_{\mathbb{K}}$ also admits two symmetric monoidal structures, respectively provided by the tensor product \otimes and by the direct sum \oplus . For the tensor product, the monoidal unit is the underlying field \mathbb{K} while the natural isomorphisms of the monoidal structure are given by

$$\alpha_{V_1, V_2, V_3} : V_1 \otimes (V_2 \otimes V_3) \rightarrow (V_1 \otimes V_2) \otimes V_3 :: v' \otimes (v'' \otimes v''') \mapsto (v' \otimes v'') \otimes v'''$$

$$\lambda_V : V \rightarrow \mathbb{K} \otimes V :: v \mapsto 1 \otimes v \quad \rho_V : V \rightarrow V \otimes \mathbb{K} :: v \mapsto v \otimes 1$$

$$\sigma_{V_1, V_2} : V_1 \otimes V_2 \rightarrow V_2 \otimes V_1 :: v' \otimes v'' \mapsto v'' \otimes v'$$

where the inverse to λ_V is

$$\lambda_V^{-1} : \mathbb{K} \otimes V \rightarrow V :: k \otimes v \mapsto k \cdot v.$$

We leave verification of bifactoriality to the reader. The ‘scalars’ (i.e. the diamonds of the graphical calculus) are provided by the field \mathbb{K} itself since it is in bijective correspondence with the linear maps from \mathbb{K} to itself. The monoidal unit for the direct sum is the 0-dimensional vector space.

Definition 12. A *dagger monoidal category* \mathbf{C} is a monoidal category which comes with an identity-on-objects contravariant involutive functor

$$\dagger : \mathbf{C}^{op} \longrightarrow \mathbf{C}$$

satisfying eq.(15) and for which all unit and associativity natural isomorphisms are unitary. A *dagger symmetric monoidal category* \mathbf{C} is both a dagger monoidal category and a symmetric monoidal category in which the symmetry natural isomorphisms is unitary.

Example 30. The category **FdHilb** admits two dagger symmetric monoidal structures respectively provided by the tensor product and by the direct sum with the adjoint of Example 21 in both cases as the dagger.

Example 31. As we will see in great detail in Section 3.2 below, the category **Rel** which has sets as objects and relations as morphisms, just like **Set**, also admits two symmetric monoidal structures, respectively provided by the Cartesian product and by the disjoint union, but unlike **Set**, it is moreover a dagger symmetric monoidal relative to both monoidal structures with the relational converse as the dagger.

Example 32. The category **2Cob** of 1-dimensional closed manifold and 2-dimensional cobordisms is dagger symmetric monoidal with the disjoint union of manifolds as its monoidal product and with the reversal of cobordism as the dagger. This will be discussed in great detail in Section 3.3.

Of course, in **FdHilb** the tensor product \otimes and the direct sum \oplus are very different monoidal structures as exemplified by the particular role each of these plays within quantum theory. In particular, as pointed out by Schrödinger in the 1930's, the tensor product description of compound quantum system is what makes quantum physics so different from classical physics. We will refer to monoidal structures which are somewhat like \otimes in **FdHilb** as *quantum-like* and to those that are rather like \oplus in **FdHilb** as *classical-like*. As we will see below, the quantum-like tensors allow for correlations between subsystems, so the joint state can in general not be reduced to states of the individual subsystems. In contrast, the classical-like tensors can only describe ‘separated’ systems, that is, the state of a joint system can always be faithfully represented by states of the individual subsystems.

The tensors considered in this paper have the following nature:

category	classical-like	quantum-like	other (see §4.3)
Set	\times		$+$
Rel	$+$	\times	
FdHilb	\oplus	\otimes	
nCob		$+$	

Observe the following remarkable facts:

- While \times behaves ‘classical-like’ in **Set**, it behaves ‘quantum-like’ in **Rel**, which contains **Set** as a sub monoidal category (in the obvious sense).
- There is a remarkable parallel between the role that the pair (\oplus, \otimes) plays for **FdHilb** and the role that the pair $(+, \times)$ plays for **Rel**.
- In **nCob** the direct sum even becomes ‘quantum-like’ – a point which has been strongly emphasized for a while by John Baez [9].

Sections 3 and 4 provide a detailed discussion of these two very distinct kinds of monoidal structures, which will shed a light on the above table. To avoid confusion concerning which monoidal structure on a category we are considering we will sometimes specify it e.g. (**FdHilb**, \otimes , \mathbb{C}).

2.5 Scalar valuation and multiples

In any monoidal category \mathbf{C} the hom-set $\mathbb{S}_{\mathbf{C}} := \mathbf{C}(I, I)$ is always a monoid with categorical composition as monoid multiplication. Therefore we call $\mathbb{S}_{\mathbf{C}}$ the *scalar monoid* of a monoidal category. It provides any monoidal category with explicit quantitative content, which, for example, in any dagger monoidal category can be produced in terms of the inner-product of Definition 10.

A fascinating fact discovered by Kelly and Laplaza in [38] is the following. Even for “non-symmetric” monoidal categories this scalar monoid will always be commutative. The proof is given by the following commutative diagram:

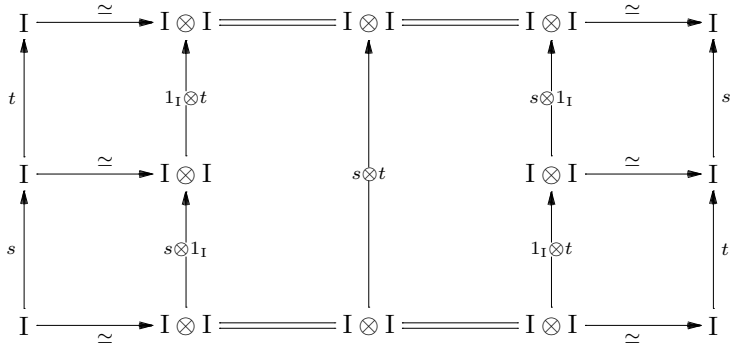

Equality of the two outer paths both going from the left-lower-corner to the right-upper-corner boils down to equality between:

- the outer left/upper path which consists of $t \circ s$ and the composite of an isomorphism $I \simeq I \otimes I$ with its inverse, i.e. 1_I , so all together $t \circ s$, and,
- the outer lower/right path $s \circ t$.

Their equality relies on bifunctoriality (cf. middle two rectangles) and naturality of the left- and right-unit isomorphisms (cf. the four squares).

Diagrammatically this fact trivially follows from the fact that scalars do not have wires and hence can ‘move freely around in the picture’:

$$\begin{array}{c} \diamond s \\ \diamond t \end{array} = \begin{array}{cc} \diamond s & \diamond t \end{array} = \begin{array}{c} \diamond t \\ \diamond s \end{array}$$

This result has physical consequences. Above we argued that strict monoidal categories model physical systems and processes thereon. We now discovered that a strict monoidal category \mathbf{C} always has a commutative endomorphism monoid $\mathbb{S}_{\mathbf{C}}$. So when varying quantum theory by changing the underlying field \mathbb{K} of the vector space we need to restrict ourselves to commutative fields, hence excluding things like ‘quaternionic quantum mechanics’ [31].

Example 33. We already saw that $\mathbb{S}_{(\mathbf{FdHilb}, \otimes, \mathbb{C})}$ is isomorphic to \mathbb{C} . Since there is only one function of type $\{*\} \rightarrow \{*\}$, namely the identity, we have that $\mathbb{S}_{(\mathbf{Set}, \times, \{*\})}$ is a singleton. So the scalar structure on $(\mathbf{Set}, \times, \{*\})$ is trivial. On the other hand, there are two relations of type $\{*\} \rightarrow \{*\}$, the identity and the empty relation, so $\mathbb{S}_{(\mathbf{Rel}, \times, \{*\})} \simeq \mathbb{B}$, the Booleans. Hence the scalar structure on $(\mathbf{Rel}, \times, \{*\})$ is non-trivial, it is that of Boolean logic. Operationally we can interpret these two scalars, for example, respectively as ‘possible’ and ‘impossible’. When rather considering \oplus on \mathbf{FdHilb} than \otimes we again have a trivial scalar structure since there is only one linear map from the 0-dimensional Hilbert space to itself. This exposes that scalars and scalar multiples are closer connected to the ‘multiplicative’ tensor product structure than to the ‘additive’ direct sum structure. As we will see below $\mathbb{S}_{(\mathbf{nCob}, +, \emptyset)} \simeq \mathbb{N}$. In general, it are the quantum-like monoidal structures which admit non-trivial scalar structure.

The right half of the above commutative diagram states that

$$s \circ t = I \xrightarrow{\simeq} I \otimes I \xrightarrow{s \otimes t} I \otimes I \xrightarrow{\simeq} I.$$

We generalize this by defining *scalar multiples* of a morphism $A \xrightarrow{f} B$ as

$$s \bullet f := A \xrightarrow{\simeq} I \otimes A \xrightarrow{s \otimes f} I \otimes B \xrightarrow{\simeq} B.$$

These scalars satisfy the usual properties, namely

$$(t \bullet g) \circ (s \bullet f) = (t \circ s) \bullet (g \circ f) \tag{26}$$

and

$$(s \bullet f) \otimes (t \bullet g) = (s \circ t) \bullet (f \otimes g), \tag{27}$$

cf. in matrix calculus we have

$$\left(y \begin{pmatrix} b_{11} & b_{12} \\ b_{21} & b_{22} \end{pmatrix} \right) \left(x \begin{pmatrix} a_{11} & a_{12} \\ a_{21} & a_{22} \end{pmatrix} \right) = yx \left(\begin{pmatrix} b_{11} & b_{12} \\ b_{21} & b_{22} \end{pmatrix} \begin{pmatrix} a_{11} & a_{12} \\ a_{21} & a_{22} \end{pmatrix} \right)$$

and

$$\left(x \begin{pmatrix} a_{11} & a_{12} \\ a_{21} & a_{22} \end{pmatrix} \right) \otimes \left(y \begin{pmatrix} b_{11} & b_{12} \\ b_{21} & b_{22} \end{pmatrix} \right) = xy \left(\begin{pmatrix} a_{11} & a_{12} \\ a_{21} & a_{22} \end{pmatrix} \otimes \begin{pmatrix} b_{11} & b_{12} \\ b_{21} & b_{22} \end{pmatrix} \right).$$

Diagrammatically these properties are again implicit and require ‘artificial’ brackets to be made explicit, for example, eq.(26) is hidden as:

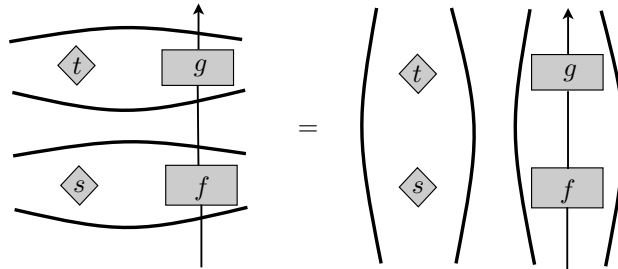

Of course, we could still prove these properties with commutative diagrams. For eq.(26) the left-hand-side the right-hand-side are respectively the top and the bottom path of the following diagram:

$$\begin{array}{ccccc}
 & & \mathbf{I} \otimes B & \xrightarrow{\lambda_B^{-1}} & B & \xrightarrow{\lambda_B} & \mathbf{I} \otimes B & & \\
 & \nearrow^{s \otimes f} & & \searrow^{\rho_{\mathbf{I}} \otimes 1_B} & & \nearrow^{\lambda_{\mathbf{I}}^{-1} \otimes 1_B} & & \searrow^{t \otimes g} & \\
 A \simeq \mathbf{I} \otimes A & & & & (\mathbf{I} \otimes \mathbf{I}) \otimes B & & & & \mathbf{I} \otimes C \simeq C \\
 & \searrow_{\rho_{\mathbf{I}} \otimes 1_A} & & \nearrow_{(s \otimes 1_{\mathbf{I}}) \otimes f} & & \searrow_{(1_{\mathbf{I}} \otimes t) \otimes g} & & \nearrow_{\lambda_{\mathbf{I}}^{-1} \otimes 1_C} & \\
 & & (\mathbf{I} \otimes \mathbf{I}) \otimes A & \xrightarrow{(s \otimes t) \otimes (g \circ f)} & (\mathbf{I} \otimes \mathbf{I}) \otimes C & & & &
 \end{array}$$

where we use the fact that $t \circ s = \lambda_{\mathbf{I}}^{-1} \circ (s \otimes t) \circ \rho_{\mathbf{I}}$. The diamond on the left commutes by naturality of $\rho_{\mathbf{I}}$. The top triangle commutes because both paths are equal to $1_{\mathbf{I} \otimes B}$ as $\lambda_{\mathbf{I}} = \rho_{\mathbf{I}}$. The bottom triangle commutes by eq.(13). Finally, the right diamond commutes by naturality of $\lambda_{\mathbf{I}}$.

3 Quantum-like tensors

So what makes \otimes so different from \oplus in the category **FdHilb**, what makes \times so different in the categories **Rel** and **Set**, and what makes \times so similar in the category **Rel** to \otimes in the category **FdHilb**?

3.1 Compact categories

Definition 13. A *compact (closed) category* **C** is a symmetric monoidal category in which every object $A \in |\mathbf{C}|$ comes with

1. another object A^* , the so-called *dual* to A ,
2. a pair of morphisms

$$\eta_A : \mathbf{I} \rightarrow A^* \otimes A \quad \text{and} \quad \epsilon_A : A \otimes A^* \rightarrow \mathbf{I},$$

the so-called *unit* and *counit*,

which are such that the following two diagrams commute:

$$\begin{array}{ccccc}
 A & \xrightarrow{\rho_A} & A \otimes \mathbf{I} & \xrightarrow{1_A \otimes \eta_A} & A \otimes (A^* \otimes A) & (28) \\
 \downarrow 1_A & & & & \downarrow \alpha_{A, A^*, A} \\
 A & \xleftarrow{\lambda_A^{-1}} & \mathbf{I} \otimes A & \xleftarrow{\epsilon_A \otimes 1_A} & (A \otimes A^*) \otimes A
 \end{array}$$

$$\begin{array}{ccccc}
 A^* & \xrightarrow{\lambda_{A^*}} & I \otimes A^* & \xrightarrow{\eta_A \otimes 1_{A^*}} & (A^* \otimes A) \otimes A^* & (29) \\
 \downarrow 1_{A^*} & & & & \downarrow \alpha_{A^*, A, A^*}^{-1} & \\
 A^* & \xleftarrow{\rho_{A^*}^{-1}} & A^* \otimes I & \xleftarrow{1_{A^*} \otimes \epsilon_A} & A^* \otimes (A \otimes A^*) & \\
 & & & & &
 \end{array}$$

In the case that \mathbf{C} is strict the above diagrams simplify to

$$\begin{array}{ccc}
 \begin{array}{ccc}
 A & & \\
 \downarrow 1_A \otimes \eta_A & \searrow 1_A & \\
 A \otimes A^* \otimes A & \xrightarrow{\epsilon_A \otimes 1_A} & A
 \end{array} & &
 \begin{array}{ccc}
 A^* & \xrightarrow{\eta_A \otimes 1_{A^*}} & A^* \otimes A \otimes A^* \\
 & \searrow 1_{A^*} & \downarrow 1_{A^*} \otimes \epsilon_A \\
 & & A^*
 \end{array} & (30)
 \end{array}$$

Definition 13 can also be expressed purely diagrammatically:

- As before A will be represented by an upward arrow:

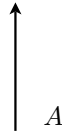

and we depict A^* either by an upward arrow labelled by A^* or by a downward arrow now labelled A :

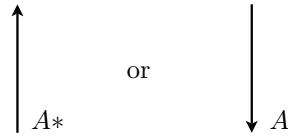

- the unit η_A and counit ϵ_A will respectively be depicted as



- Commutation of the two diagrams now boils down to:

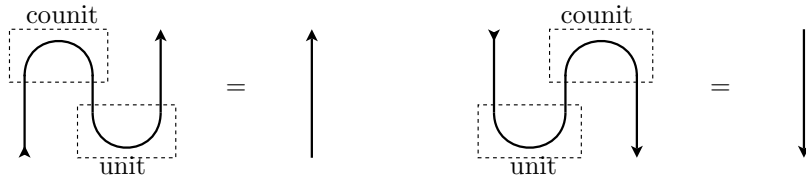

These equational constraints, when diagrammatically expressed, admit the simple interpretation of ‘yanking a wire’. While at first sight compactness of a category as stated in Definition 13 seems to be a somewhat ad hoc notion, this graphical interpretation establishes it as a very canonical one which extends the graphical calculus for symmetric monoidal categories with *cup*- and *cap*-shaped wires. As the following lemma shows, the equational constraints imply that we are allowed to ‘slide’ morphisms also along these cups and caps.

Lemma 1. *Given a morphism $f : A \rightarrow B$ define its transpose to be*

$$f^* := (1_{B^*} \otimes \epsilon_A) \circ (1_{B^*} \otimes f \otimes 1_{A^*}) \circ (\eta_B \otimes 1_{A^*}) : B^* \rightarrow A^* .$$

Diagrammatically, when depicting the morphism f as

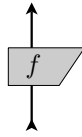

then its transpose depicts as

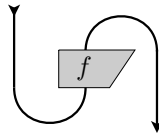

Anticipating what will follow, we abbreviate this notation for f^ to*

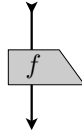

We have:

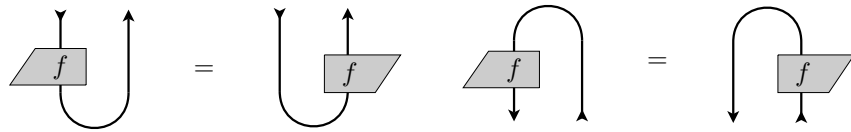

that is, we can ‘slide’ morphisms along cup- and cap-shaped wires.

The proof of the first equality is

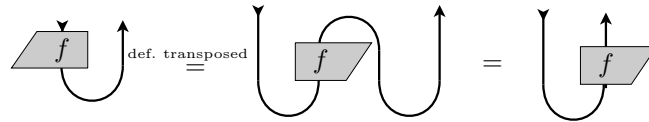

and that for the second equality proceeds analogously.

Example 34. The category $\mathbf{FdVect}_{\mathbb{K}}$ is compact. We take the usual linear algebraic dual space V^* to be V 's dual object, we take the unit to be

$$\eta_V : \mathbb{K} \rightarrow V^* \otimes V :: 1 \mapsto \sum_{i=1}^n f_i \otimes e_i,$$

where $\{e_i\}_{i=1}^n$ a basis of V and $f_i \in V^*$ is the linear functional such that $f_j(e_i) = \delta_{i,j}$ for all $1 \leq i, j \leq n$, and we take the counit to be

$$\epsilon_V : V \otimes V^* \rightarrow \mathbb{K} :: e_i \otimes f_j \mapsto f_j(e_i).$$

Two important points need to be made here:

- The linear maps η_V and ϵ_V do not depend on the choice of the basis $\{e_i\}_{i=1}^n$. It suffices to verify that there is a canonical isomorphism

$$\mathbf{FdVect}_{\mathbb{K}}(V, V) \xrightarrow{\cong} \mathbf{FdVect}_{\mathbb{K}}(\mathbb{K}, V^* \otimes V)$$

which does not depend on the choice of basis. The unit η_V is the image of 1_V under this isomorphism and since 1_V is independent of the choice of basis it follows that η_V does not depend on any choice of basis. The argument for ϵ_V proceeds analogously.

- There are other possible choices η_V and ϵ_V which turn $\mathbf{FdVect}_{\mathbb{K}}$ into a compact category. For example, if $f : V \rightarrow V$ is invertible then

$$\eta'_V := (1_{V^*} \otimes f) \circ \eta_V \quad \text{and} \quad \epsilon'_V := \epsilon_V \circ (f^{-1} \otimes 1_{V^*})$$

make diagrams (28) and (29), we have

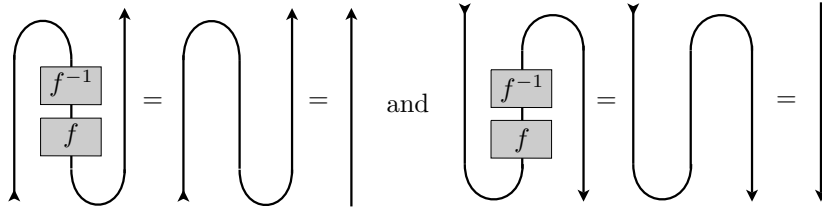

thus, the compactness conditions are satisfied.

Example 35. The category \mathbf{Rel} of sets and relations is also compact relative to the Cartesian product as we shall see in detail in Section 3.2.

Example 36. The category $\mathbf{QuantOpp}$ is compact. We can pick Bell-states as the units and the corresponding Bell-effects as counits. As shown in [2, 17] compactness is exactly what enables protocols such as quantum teleportation:

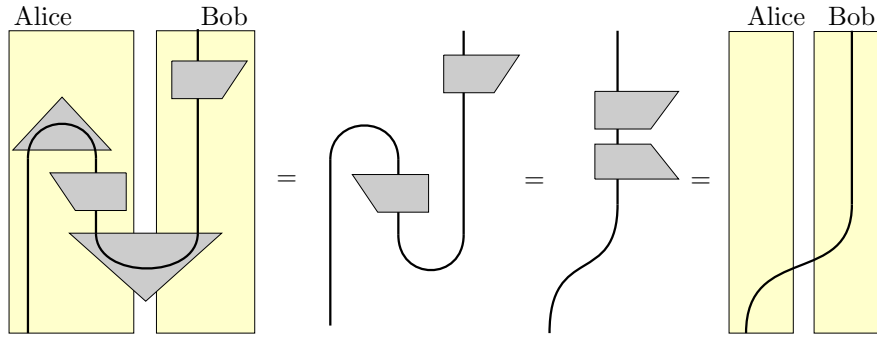

where the trapezoid is unitary and hence, its dagger coincides with its inverse. The classical information flow is (implicitly) encoded in the fact that the same trapezoid appears in the left-hand-side picture both at Alice's and Bob's side.

Given a morphism $f : A \rightarrow B$ in a compact category we define its *name* $\ulcorner f \urcorner : I \rightarrow A^* \otimes B$ and its *coname* $\lrcorner f \lrcorner : A \otimes B^* \rightarrow I$ to be

$$\begin{array}{ccc}
 A^* \otimes A & \xrightarrow{1_{A^*} \otimes f} & A^* \otimes B \\
 \eta_A \uparrow & \nearrow \ulcorner f \urcorner & \\
 I & &
 \end{array}
 \quad \text{and} \quad
 \begin{array}{ccc}
 & & I \\
 & \lrcorner f \lrcorner \nearrow & \uparrow \epsilon_B \\
 A \otimes B^* & \xrightarrow{f \otimes 1_{B^*}} & B \otimes B^*
 \end{array}$$

respectively. Following [2] we can show that for $f : A \rightarrow B$ and $g : B \rightarrow C$

$$\lambda_C^{-1} \circ (\lrcorner f \lrcorner \otimes 1_C) \circ (1_A \otimes \ulcorner g \urcorner) \circ \rho_A = g \circ f$$

always holds. The graphical proof is trivial:

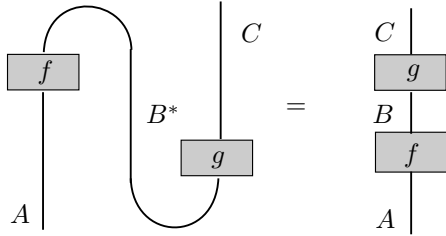

In contrast a (non-strict) symbolic proof goes as follows:

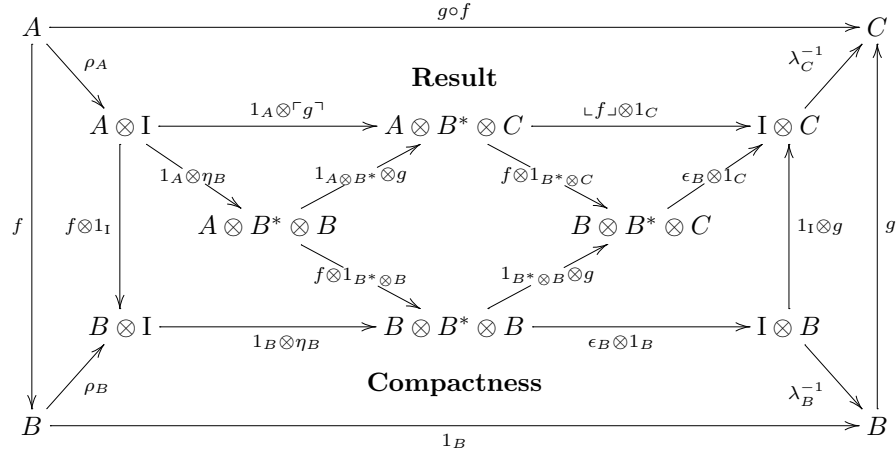

Both paths on the outside are equal to $g \circ f$. We want to show that the pentagon labelled ‘Result’ commutes. To do this we will ‘unfold’ arrows using equations which hold in compact categories, in order to pass from the composite $f \circ g$ at the left/bottom/right to $\lambda_C^{-1} \circ (\lrcorner f \lrcorner 1_C) \circ (1_A \otimes \lrcorner g \lrcorner) \circ \rho_A$. This will transform the tautology $g \circ f = g \circ f$ into commutation of the pentagon labelled ‘Result’. For instance, we use compactness to go from the identity arrow at the bottom of the diagram to the composite $\lambda_B^{-1} \circ (\epsilon_B \otimes 1_B) \circ (1_B \otimes \eta_B) \circ \rho_B$. The outer left and right trapezoids express naturality of ρ and λ . The remaining triangles/diamond express bifunctionality and the definitions of name/coname.

The scalar $\epsilon_A \circ \sigma_{A^*,A} \circ \eta_A : \mathbb{K} \rightarrow \mathbb{K}$ depicts as

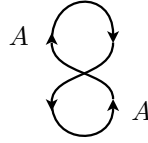

and when setting

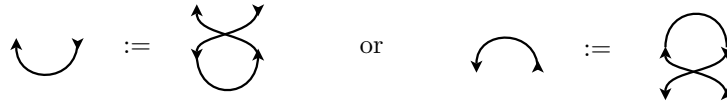

becomes an ‘A-labelled circle’



Example 37. In $\mathbf{FdVect}_{\mathbb{K}}$ the V -labelled circle stands for the dimension of the vector space V . By the definition of η_V and ϵ_V the previous composite is equal to

$$\sum_{ij} f_j(e_i) = \sum_{ij} \delta_{i,j} = \sum_i 1 = \dim(V).$$

Definition 14. A *dagger compact category* is both a compact category and a dagger symmetric monoidal category for which $\epsilon_A = \eta_A^\dagger \circ \sigma_{A,A^*}$.

Example 38. The category **FdHilb** is dagger compact.

3.2 The category of relations

We now turn our attention to the category **Rel** of sets and relations, a category which we briefly encountered in previous sections. Perhaps surprisingly, **Rel** possesses more ‘quantum features’ than the category **Set** of sets and functions, in the sense that it is an instance of a dagger compact category.

A *relation* $R : X \rightarrow Y$ between two sets X and Y is a subset of the set of all their pairs which means that $R \subseteq X \times Y$. Thus, given element $(x, y) \in R$, we say that $x \in X$ is *related* to $y \in Y$ which we denote as xRy . Typically, we will denote such a relation R by its graph:

$$R := \{(x, y) \mid xRy\}.$$

Example 39. For the relation “strictly inferior to” or ‘<’ on the natural numbers we have 2 is related to 5, which is denoted as $2 < 5$ or $(2, 5) \in < \subseteq \mathbb{N} \times \mathbb{N}$. For the relation “is a divisor of” or ‘|’ on the natural numbers we have $6|36$ or $(6, 36) \in | \subseteq \mathbb{N} \times \mathbb{N}$. Other examples are general preorders or equivalence relations.

Definition 15. The monoidal category **Rel** is defined as follows:

- objects are all sets;
- morphisms are all relations $R : X \rightarrow Y$;
- for $R_1 : X \rightarrow Y$ and $R_2 : Y \rightarrow Z$ the composite $R_2 \circ R_1 \subseteq X \times Z$ is

$$R_2 \circ R_1 := \{(x, z) \mid \text{there exists a } y \in Y \text{ such that } xR_1y \text{ and } yR_2z\}$$

which is easily seen to be associative with for $X \in |\mathbf{Rel}|$ the identity

$$1_X := \{(x, x) \mid x \in X\};$$

- the monoidal product of two sets is their Cartesian product, the unit for the monoidal structure is the singleton, and for two relations $R_1 : X_1 \rightarrow Y_1$ and $R_2 : X_2 \rightarrow Y_2$ the monoidal product $R_1 \times R_2 \subseteq X_1 \times X_2 \rightarrow Y_1 \times Y_2$ is

$$R_1 \times R_2 := \{((x, x'), (y, y')) \mid xR_1y \text{ and } x'R_2y'\}.$$

We said before that **Set** was contained in **Rel** as a submonoidal category in the obvious sense. Explicitly the left and right unit natural isomorphisms are

$$\lambda_X := \{(x, (x, *)) \mid x \in X\} \quad \text{and} \quad \rho_X := \{(x, (*, x)) \mid x \in X\}$$

respectively and the associativity natural isomorphism is

$$\alpha_{X,Y,Z} := \{((x, (y, z)), ((x, y), z)) \mid x \in X, y \in Y \text{ and } z \in Z\}.$$

When conceiving these relations as functions (which these particular ones indeed are) they are the same as the natural isomorphisms for the Cartesian product in **Set**. Let us verify the coherence conditions for them:

(i) The pentagon

$$\begin{array}{ccc} W \times (X \times (Y \times Z)) & \xrightarrow{\alpha_-} & (W \times X) \times (Y \times Z) \xrightarrow{\alpha_-} & ((W \times X) \times Y) \times Z \\ & \downarrow 1 \times \alpha_- & & \uparrow \alpha_- \times 1 \\ W \times ((X \times Y) \times Z) & \xrightarrow{\alpha_-} & & (W \times (X \times Y)) \times Z \end{array}$$

indeed commutes. For the top part, we have

$$\alpha_- \circ \alpha_- : W \times (X \times (Y \times Z)) \rightarrow ((W \times X) \times Y) \times Z$$

which is, by definition, a subset of

$$W \times (X \times (Y \times Z)) \times ((W \times X) \times Y) \times Z$$

and, by the definition of relational composition, is given by

$$\alpha_- \circ \alpha_- = \left\{ ((w, (x, (y, z))), ((w'', x''), y''), z'') \mid \exists ((w', x'), (y', z')) \text{ s.t.} \right. \\ \left. ((w, (x, (y, z)))\alpha((w', x'), (y', z'))) \text{ and } ((w', x'), (y', z'))\alpha(((w'', x''), y''), z'') \right\}.$$

But by definition of α , the previous expression is simply

$$\alpha_- \circ \alpha_- = \{((w, (x, (y, z))), (((w, x), y), z)) \mid w \in W, x \in X, y \in Y, z \in Z\}.$$

The bottom path is done analogously and gives the same result, hence making the pentagon commute. For the remaining diagrams we leave the details to the reader.

(ii) Similarly the triangle

$$\begin{array}{ccc} X \times Y & \xrightarrow{1_A \times \lambda_Y} & X \times (\{*\} \times Y) \\ & \searrow \rho_X \times 1_Y & \downarrow \alpha_{X; \{*\}, Y} \\ & & (X \times \{*\}) \times Y \end{array}$$

commutes as both paths are now equal to

$$\{((x, y), ((x, *), y)) \mid x \in X \text{ and } y \in Y\}.$$

As \times is symmetric in **Set** we also expect **Rel** to be symmetric monoidal. For any X and $Y \in |\mathbf{Rel}|$, the natural isomorphism

$$\sigma_{X,Y} := \{((x, y), (y, x)) \mid x \in X \text{ and } y \in Y\}$$

also obeys the coherence conditions:

(i) The two triangles

$$\begin{array}{ccc} X \times Y & \xrightarrow{\sigma_{X,Y}} & Y \times X \\ & \searrow & \downarrow \sigma_{Y,X} \\ & & X \times Y \end{array}, \quad \begin{array}{ccc} X & \xrightarrow{\lambda_X} & \{*\} \times X \\ & \searrow \rho_X & \downarrow \sigma_{\{*\},X} \\ & & X \times \{*\} \end{array}$$

commute since both paths of the left triangle are equal to

$$\{((x, y), (x, y)) \mid x \in X \text{ and } y \in Y\}$$

while the paths of the left triangle are equal to

$$\{(x, (x, *)) \mid x \in X\}.$$

• (ii) Both the following and the inverse hexagon

$$\begin{array}{ccccc} X \times (Y \times Z) & \xrightarrow{\alpha_-} & (X \times Y) \times Z & \xrightarrow{\sigma_{(X \times Y),Z}} & Z \times (X \times Y) \\ \downarrow 1_X \times \sigma_{Y,Z} & & & & \downarrow \alpha_- \\ (Z \times Y) & \xrightarrow{\alpha_-} & (X \times Z) \times Y & \xrightarrow{\sigma_{X,Y} \times 1_Z} & (Z \times X) \times Y \end{array}$$

commute as both paths are equal to

$$\{((x, (y, z)), ((z, x), y)) \mid x \in X, y \in Y \text{ and } z \in Z\}.$$

So **Rel** is indeed symmetric monoidal category as expected. But **Rel** shares many more common characteristics with **FdHilb**, one of them being a \dagger -compact structure. Firstly, **Rel** is compact closed with self-dual objects that is, $X^* = X$ for any $X \in |\mathbf{Rel}|$. Moreover, for any $X \in |\mathbf{Rel}|$ let

$$\eta_X : \{*\} \rightarrow X \times X := \{(*, (x, x)) \mid x \in X\}$$

and

$$\epsilon_X : X \times X \rightarrow \{*\} := \{((x, x), *) \mid x \in X\}.$$

These morphisms make

$$\begin{array}{ccccc} X & \xrightarrow{\rho_X} & X \times \{*\} & \xrightarrow{1_X \times \eta_X} & X \times (X \times X) \\ \downarrow 1_X & & & & \downarrow \alpha_- \\ X & \xleftarrow{\lambda_X^{-1}} & \{*\} \times X & \xleftarrow{\epsilon_X \times 1_X} & (X \times X) \times X \end{array}$$

and its dual both commute. Indeed:

(a) The composite

$$(1_X \times \eta_X) \circ \rho_X : X \rightarrow X \times (X \times X)$$

is the set of tuples

$$\{(x, (x', (x'', x''')))\} \subseteq X \times (X \times (X \times X))$$

such that there exists an $(x'''' , *) \in X \times \{*\}$ with

$$x \rho_X (x'''' , *) \quad \text{and} \quad (x'''' , *) (1_X \times \eta_X) (x', (x'', x''')) .$$

By definition of ρ , 1_X and the product of relations, this entails that x, x'''' and x' are all equal. Moreover, by definition of η_X and the product of relations, we have that x'' and x''' are also equal. Thus,

$$(1_X \times \eta_X) \circ \rho_X := \{(x, (x, (x', x'))) \mid x, x' \in X\} .$$

(b) Hence the composite

$$\alpha \circ ((1_X \times \eta_X) \circ \rho) : X \rightarrow (X \times X) \times X$$

is

$$\alpha \circ ((1_X \times \eta_X) \circ \rho) = \{(x, ((x, x'), x')) \mid x, x' \in X\} .$$

(c) The composite

$$(\epsilon_X \times 1_X) \circ (\alpha \circ (1_X \times \eta_X) \circ \rho) : X \rightarrow \{*\} \times X$$

is a set of tuples $\{(x, (*, x'))\} \subseteq X \times (\{*\} \times X)$ such that there exists an $((x'', x'''), x'''') \in (X \times X) \times X$ with

$$x (\alpha \circ (1_X \times \eta_X) \circ \rho) ((x'', x'''), x'''') \quad \text{and} \quad ((x'', x'''), x'''') (\epsilon_X \times 1_X) (*, x') .$$

By the computation in (b) we have $x = x''$ and $x''' = x''''$. By definition of ϵ_X , 1_X and the product of relations we have $x'' = x'''$ and $x'''' = x'$. All this together yields $x = x'' = x''' = x'''' = x'$ and hence

$$(\epsilon_X \otimes 1_X) \circ (\alpha \circ (1_X \otimes \eta_X) \circ \rho) = \{(x, (*, x)) \mid x \in X\} .$$

(d) Composing the previous composite with λ_X^{-1} yields a morphism of type $X \rightarrow X$ namely

$$\lambda_X^{-1} \circ (\epsilon_X \otimes 1_X) \circ \alpha \circ (1_X \otimes \eta_X) \circ \rho = \{(x, x) \mid x \in X\}$$

which is the relation 1_X as required.

Commutation of the dual diagram is done analogously. From this, we conclude that \mathbf{Rel} is compact closed. The obvious candidate for the dagger

$$\dagger : \mathbf{Rel}^{op} \rightarrow \mathbf{Rel}$$

is the relational converse. For relation $R : X \rightarrow Y$ its converse $R^\cup : Y \rightarrow X$ is

$$R^\cup := \{(y, x) \mid xRy\}.$$

We define the contravariant identity-on-object involutive functor

$$\dagger : \mathbf{Rel} \rightarrow \mathbf{Rel} :: R \mapsto R^\cup.$$

Note that $R^* = R^\dagger$. Indeed, given a relation $R : X \rightarrow Y$ then

$$R^* = (1_X \times \epsilon_Y) \circ (1_X \times R \times 1_Y) \circ (\eta_X \times 1_Y) = R^\dagger$$

as the reader may easily check. This makes the functor

$$(-)_* = (-)^{\dagger*} = (-)^{\dagger*} : \mathbf{Rel} \rightarrow \mathbf{Rel}$$

an identity. Finally, verify that \mathbf{Rel} is dagger compact:

- The category \mathbf{Rel} is dagger monoidal:
 - (i) From the definition of the monoidal product of two relations

$$R_1 := \{(x, y) \mid xR_1y\} \quad \text{and} \quad R_2 := \{(x', y') \mid y'R_2y'\}$$

we have that

$$(R_1 \times R_2)^\dagger = \{((x', y'), (x, y)) \mid xR_1y \text{ and } x'R_2y'\} = R_1^\dagger \times R_2^\dagger.$$

- (ii) The fact that $\alpha^\dagger = \alpha^{-1}$, $\lambda^\dagger = \lambda^{-1}$, $\rho^\dagger = \rho^{-1}$ and $\sigma^\dagger = \sigma^{-1}$ is trivial as the inverse of all these morphism is the relational converse.

- The diagram

$$\begin{array}{ccc} \{*\} & \xrightarrow{\epsilon_X^\dagger} & X \times X \\ & \searrow \eta_X & \downarrow \sigma_{X,X} \\ & & X \times X \end{array}$$

commutes since from

$$\epsilon_X := \{((x, x), *) \mid x \in X\}$$

follows

$$\epsilon_X^\dagger := \{(*, (x, x)) \mid x \in X\}$$

and hence $\sigma \circ \epsilon_X^\dagger = \epsilon_X^\dagger = \eta_X$.

So \mathbf{Rel} is indeed a dagger compact category.

3.3 The category of 2D cobordisms

The category **2Cob** can be informally described as a category whose morphisms –the *cobordisms*– describe the ‘evolution’ of manifolds of dimension $2 - 1 = 1$ through time, although technically speaking, we should actually speak of ‘topological evolution’. For instance, consider the evolution of two circles smoothly merging into a single circle, then a few frames illustrating such a process are

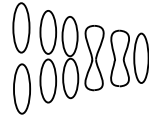

Passing to the continuum, the same process can be described by the cobordism



Thus, for our purpose, a cobordism is seen as 2-dimensional manifold whose boundary is partitioned in two: the domain and the codomain of the cobordism, each being closed manifolds of dimension 1. Therefore, these must be a finite number n of ‘strings’ that are homeomorphic to circles.

Definition 16. The category **2Cob** is defined as follows:

- objects are natural numbers, which represents the number of strings:

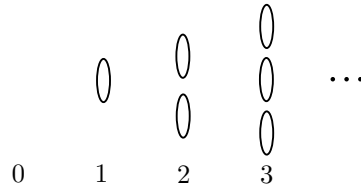

- morphisms are cobordisms $M : n \rightarrow m$ taking n (strings) to m (strings), which are defined up to homeomorphic equivalence that is, a cobordism can be deformed at will as long as we preserve its topological properties.
- For each object n , there is an identity $1_n : n \rightarrow n$ which is given by n parallel cylinders:

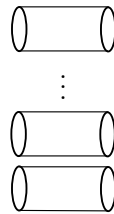

Composition is given by “gluing” manifolds together e.g.

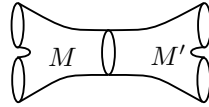

is the composition $M' \circ M : 2 \rightarrow 2$ where $M' : 1 \rightarrow 2$ is glued to $M : 2 \rightarrow 1$ along the object 1.

As already mentioned this category has a monoidal structure given by the disjoint union of manifolds. For instance, if $M : 1 \rightarrow 0$ and $M' : 2 \rightarrow 1$ are cobordisms, then $M + M' : 1 + 2 \rightarrow 0 + 1$ depicts as:

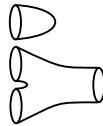

where we make the convention to depict M on the top of M' . The empty manifold 0 is the identity for the disjoint union hence $0 + 1 \simeq 1$. This category is symmetric monoidal since we can define a *twist* cobordism, for example, the twist $T_{1,1} : 1 + 1 \rightarrow 1 + 1$ is depicted as

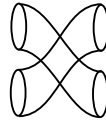

The generalisation of such morphism to $T_{n,m} : m+n \rightarrow n+m$ for any $m, n \in \mathbb{N}$ should be obvious. Moreover, **2Cob** happens to be compact. We start by the unit $\eta_1 : 0 \rightarrow 1 + 1$ which is given by the cobordism



The counit $\epsilon_1 : 1 + 1 \rightarrow 0$ is



and we recover the equations of compactness as

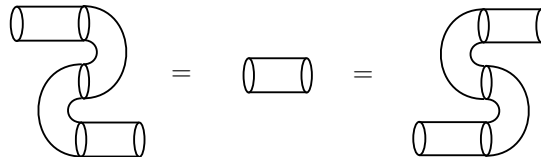

which holds since all cobordisms involved are homeomorphically equivalent. The generalisation of the units to arbitrary n should be obvious:

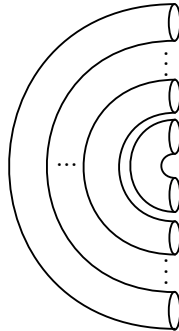

and these are easily seen to always satisfy the equations of compactness. We can also define a dagger for the category $\mathbf{2Cob}$ merely by ‘flipping’ the cobordisms, e.g. if $M : 2 \rightarrow 1$ is

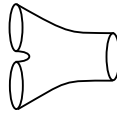

then its dagger $M^\dagger : 1 \rightarrow 2$ is



Clearly the dagger is compatible with the disjoint union which makes $\mathbf{2Cob}$ a dagger monoidal category. It is also dagger compact since $\sigma_{1,1} \circ \epsilon_1^\dagger$ is

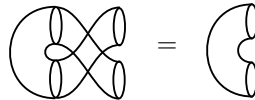

which is easily seen to be true for arbitrary n .

Obviously we have been very informal here. For a more elaborated discussion and technical details we refer the reader to [9, 10, 39, 62]. The key thing to remember is that there are important ‘concrete’ categories in which the morphisms are nothing like maps from the domain to the codomain. Note also that we can conceive –again very informally– the diagrammatic calculus of the previous sections as the result of contracting the diameter of the strings in $\mathbf{2Cob}$ to zero. These categories of cobordisms play a key role in *topological quantum field theory* (TQFT). We briefly discuss this topic in Section 5.5.

4 Classical-like tensors

The tensors to which we referred as classical-like are not compact. Instead they do come with some other structure which, in all non-trivial cases, turns out to be incompatible with compactness [1]. In fact, this incompatibility is the abstract incarnation of the No-Cloning theorem which plays a central role in quantum information science [26, 65].

4.1 Cartesian categories

Consider the category **Set** with the Cartesian product as the monoidal tensor, as defined in Example 27. Given sets $A_1, A_2 \in |\mathbf{Set}|$, their Cartesian product $A_1 \times A_2$ consists of all pairs (x_1, x_2) with $x_1 \in A_1$ and $x_2 \in A_2$. The fact that Cartesian products consist of pairs is witnessed by the *projection* maps

$$\pi_1 : A_1 \times A_2 \rightarrow A_1 :: (x_1, x_2) \mapsto x_1 \quad \text{and} \quad \pi_2 : A_1 \times A_2 \rightarrow A_2 :: (x_1, x_2) \mapsto x_2,$$

which identify the respective components, together with the fact that, in turns, we can *pair* $x_1 = \pi_1(x_1, x_2) \in A_1$ and $x_2 = \pi_2(x_1, x_2) \in A_2$ back together into $(x_1, x_2) \in A_1 \times A_2$ merely by putting brackets around them. However, both the projections and the pairing operation are expressed in terms of their action on elements, while categorical structure only recognises hom-sets, and not the internal structure of the underlying objects. Therefore, instead, we consider the action of projections on hom-sets, namely

$$\pi_1 \circ - : \mathbf{Set}(C, A_1 \times A_2) \rightarrow \mathbf{Set}(C, A_1) :: f \mapsto \pi_1 \circ f$$

$$\pi_2 \circ - : \mathbf{Set}(C, A_1 \times A_2) \rightarrow \mathbf{Set}(C, A_2) :: f \mapsto \pi_2 \circ f,$$

which we can combine into a single operation ‘decompose’

$$\text{dec}_C^{A_1, A_2} : \mathbf{Set}(C, A_1 \times A_2) \rightarrow \mathbf{Set}(C, A_1) \times \mathbf{Set}(C, A_2) :: f \mapsto (\pi_1 \circ f, \pi_2 \circ f),$$

together with the operation ‘recombine’

$$\text{rec}_C^{A_1, A_2} : \mathbf{Set}(C, A_1) \times \mathbf{Set}(C, A_2) \rightarrow \mathbf{Set}(C, A_1 \times A_2) :: (f_1, f_2) \mapsto \langle f_1, f_2 \rangle$$

where

$$\langle f_1, f_2 \rangle : C \rightarrow A_1 \times A_2 :: c \mapsto (f_1(c), f_2(c)).$$

In this form we have

$$\text{dec}_C^{A_1, A_2} \circ \text{rec}_C^{A_1, A_2} = 1_{\mathbf{Set}(C, A_1) \times \mathbf{Set}(C, A_2)}$$

and

$$\text{rec}_C^{A_1, A_2} \circ \text{dec}_C^{A_1, A_2} = 1_{\mathbf{Set}(C, A_1 \times A_2)}$$

so $\text{dec}_C^{A_1, A_2}$ and $\text{rec}_C^{A_1, A_2}$ are now effectively each others inverses. In the light of Example 3, setting $C := \{*\}$, we obtain

$$\begin{array}{ccc}
& \xrightarrow{\text{dec}_{\{\ast\}}^{A_1, A_2}} & \\
\mathbf{Set}(\{\ast\}, A_1 \times A_2) & & \mathbf{Set}(\{\ast\}, A_1) \times \mathbf{Set}(\{\ast\}, A_2), \\
& \xleftarrow{\text{rec}_{\{\ast\}}^{A_1, A_2}} &
\end{array}$$

which corresponds to projecting and pairing elements, as in the discussion at the beginning of this section. All of this extends in abstract generality.

Definition 17. A *product* of two objects A_1 and A_2 in a category \mathbf{C} is a triple consisting of another object $A_1 \times A_2 \in |\mathbf{C}|$ together with two morphisms

$$\pi_1 : A_1 \times A_2 \rightarrow A_1 \quad \text{and} \quad \pi_2 : A_1 \times A_2 \rightarrow A_2$$

which are such that the mapping

$$(\pi_1 \circ -, \pi_2 \circ -) : \mathbf{C}(C, A_1 \times A_2) \rightarrow \mathbf{C}(C, A_1) \times \mathbf{C}(C, A_2) \quad (31)$$

admits an inverse $\langle -, - \rangle_{C, A_1, A_2}$ for all $C, A_1, A_2 \in |\mathbf{C}|$.

Below we omit the indices C, A_1, A_2 in $\langle -, - \rangle_{C, A_1, A_2}$.

Definition 18 (Cartesian category). A category \mathbf{C} is *Cartesian* if any pair of objects $A, B \in |\mathbf{C}|$ admits a (not necessarily unique) product.

Proposition 3. *If a pair of objects admits two distinct products then the carrier objects are isomorphic in the category-theoretic sense of Definition 2.*

Indeed, suppose that in \mathbf{C} the objects A_1 and A_2 have two products $A_1 \times A_2$ and $A_1 \boxtimes A_2$ with respective projections

$$\pi_i : A_1 \times A_2 \rightarrow A_i \quad \text{and} \quad \pi'_j : A_1 \boxtimes A_2 \rightarrow A_j.$$

Then consider the pairs of morphisms

$$(\pi'_1, \pi'_2) \in \mathbf{C}(A_1 \boxtimes A_2, A_1) \times \mathbf{C}(A_1 \boxtimes A_2, A_2)$$

and

$$(\pi_1, \pi_2) \in \mathbf{C}(A_1 \times A_2, A_1) \times \mathbf{C}(A_1 \times A_2, A_2).$$

By Definition 17 we can apply the respective inverses of $(\pi_1 \circ -, \pi_2 \circ -)$ and $(\pi'_1 \circ -, \pi'_2 \circ -)$ to these pairs yielding morphism in

$$\mathbf{C}(A_1 \boxtimes A_2, A_1 \times A_2) \quad \text{and} \quad \mathbf{C}(A_1 \times A_2, A_1 \boxtimes A_2),$$

say f and g respectively, for which we have that

$$\pi'_1 = \pi_1 \circ f, \quad \pi'_2 = \pi_2 \circ f, \quad \pi_1 = \pi'_1 \circ g \quad \text{and} \quad \pi_2 = \pi'_2 \circ g.$$

Then, it follows that

$$(\pi'_1 \circ 1_{A_1 \boxtimes A_2}, \pi'_2 \circ 1_{A_1 \boxtimes A_2}) = (\pi_1 \circ f, \pi_2 \circ f) = (\pi'_1 \circ g \circ f, \pi'_2 \circ g \circ f)$$

and applying the inverse to $(\pi'_1 \circ -, \pi'_2 \circ -)$ now gives $1_{A_1 \boxtimes A_2} = g \circ f$. An analogue argument gives $f \circ g = 1_{A_1 \times A_2}$ so f is an isomorphism, with g as its inverse, between the two objects $A_1 \times A_2$ and $A_1 \boxtimes A_2$.

The above definition of products in terms of ‘decomposing and recombining compound objects’ is not the one that one usually finds in the literature.

Definition 19. A *product* of two objects A and A_2 in a category \mathbf{C} is a triple consisting of another object $A_1 \times A_2 \in |\mathbf{C}|$ together with two morphisms

$$\pi_1 : A_1 \times A_2 \rightarrow A_1 \quad \text{and} \quad \pi_2 : A_1 \times A_2 \rightarrow A_2$$

such that for any object $C \in |\mathbf{C}|$, and any pair of morphisms $C \xrightarrow{f_1} A_1$ and $C \xrightarrow{f_2} A_2$ in \mathbf{C} , there exists a unique morphism $C \xrightarrow{f} A_1 \times A_2$ such that

$$f_1 = \pi_1 \circ f \quad \text{and} \quad f_2 = \pi_2 \circ f.$$

We can concisely summarise the required so-called *universal* property by the commutative diagram

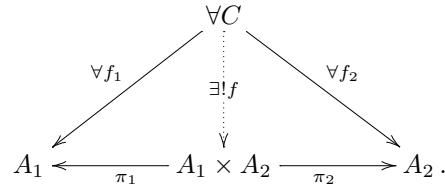

It is easy to see that this definition is equivalent with the previous one: the inverse $\langle -, - \rangle$ to $(\pi_1 \circ -, \pi_2 \circ -)$ provides for any pair (f_1, f_2) a unique morphism $f := \langle f_1, f_2 \rangle$ which is such that $(\pi_1 \circ f, \pi_2 \circ f) = (f_1, f_2)$, and conversely, uniqueness of $C \xrightarrow{f} A_1 \times A_2$ guarantees $(\pi_1 \circ -, \pi_2 \circ -)$ to have an inverse $\langle -, - \rangle$, which is obtained by setting $\langle f_1, f_2 \rangle := f$.

For more details on this definition and the reason for its prominence in the literature we refer to [4] and standard textbooks such as [5, 47].

Proposition 4. *If a category \mathbf{C} is Cartesian then each choice of a product for each pair of objects always defines a symmetric monoidal structure on \mathbf{C} , with $A \otimes B := A \times B$, and with the terminal object as the monoidal unit.*

Proving this requires some work. For $f : A_1 \rightarrow B_1$ and $g : A_2 \rightarrow B_2$ let

$$f \times g : A_1 \times A_2 \rightarrow B_1 \times B_2$$

be the unique morphism defined in terms of Definition 19 within

$$\begin{array}{ccccc}
& & A_1 \times A_2 & & \\
& \swarrow f \circ \pi_1 & \vdots f \times g & \searrow g \circ \pi_2 & \\
B_1 & \xleftarrow{\pi'_1} & B_1 \times B_2 & \xrightarrow{\pi'_2} & B_2
\end{array}$$

Then it obviously immediately follows that the diagrams

$$\begin{array}{ccccc}
A_1 & \xleftarrow{\pi_1} & A_1 \times A_2 & \xrightarrow{\pi_2} & A_2 \\
\downarrow f & & \downarrow f \times g & & \downarrow g \\
B_1 & \xleftarrow{\pi'_1} & B_1 \times B_2 & \xrightarrow{\pi'_2} & B_2
\end{array} \tag{32}$$

commute. From Definition 17 we know that

$$\langle \pi_1 \circ f, \pi_2 \circ f \rangle = f \tag{33}$$

and this in particular entails

$$\langle \pi_1, \pi_2 \rangle = \langle \pi_1 \circ 1_{A_1 \times A_2}, \pi_2 \circ 1_{A_1 \times A_2} \rangle = 1_{A_1 \times A_2}. \tag{34}$$

Using eq.(33) for $A \xrightarrow{f} B$, $B \xrightarrow{g} C$ and $B \xrightarrow{h} D$ we have

$$\begin{aligned}
\langle g, h \rangle \circ f &= \langle \pi_1 \circ (\langle g, h \rangle \circ f), \pi_2 \circ (\langle g, h \rangle \circ f) \rangle \\
&= \langle (\pi_1 \circ \langle g, h \rangle) \circ f, (\pi_2 \circ \langle g, h \rangle) \circ f \rangle \\
&= \langle g \circ f, h \circ f \rangle.
\end{aligned}$$

Using this, for $A \xrightarrow{f} B$, $A \xrightarrow{g} C$, $B \xrightarrow{h} D$ and $C \xrightarrow{k} E$ we have

$$\begin{aligned}
(h \times k) \circ \langle f, g \rangle &= \langle h \circ \pi_1, k \circ \pi_2 \rangle' \circ \langle f, g \rangle \\
&= \langle h \circ \pi_1 \circ \langle f, g \rangle, k \circ \pi_2 \circ \langle f, g \rangle \rangle' \\
&= \langle h \circ f, k \circ g \rangle'
\end{aligned}$$

where $\langle -, - \rangle'$ is the pairing operations relative to $(\pi'_1 \circ -, \pi'_2 \circ -)$. In a similar manner the reader can verify that $- \times -$ is bifunctorial.

To support the claim in Proposition 4 we will now also construct the required natural isomorphisms and leave verification of the coherence diagrams to the reader. Let $!_A$ be the unique morphism of type $A \rightarrow \top$. Setting

$$\lambda_A := \langle !_A, 1_A \rangle : A \rightarrow \top \times A$$

we have

$$\langle !_B, 1_B \rangle \circ f = \langle !_B \circ f, 1_B \circ f \rangle = \langle !_A, f \circ 1_A \rangle = (!_\top \times f) \langle !_A, 1_A \rangle.$$

so we have established commutation of

$$\begin{array}{ccc} A & \xrightarrow{\lambda_A} & \top \times A \\ f \downarrow & & \downarrow 1_{\top \times f} \\ B & \xrightarrow{\lambda_B} & \top \times B \end{array}$$

that is, λ is natural. The components are moreover isomorphisms with π_2 as inverse. The fact that $\pi_2 \circ \lambda_A = 1_A$ holds by definition, and from

$$\begin{array}{ccccc} \top & \xleftarrow{\pi_1} & \top \times A & \xrightarrow{\pi_2} & A \\ \downarrow !_\top & & \downarrow !_\top \times 1_A & & \downarrow 1_A \\ \top & \xleftarrow{\pi'_1} & \top \times A & \xrightarrow{\pi'_2} & A \end{array}$$

and the fact that by the terminality of \top we have

$$!_{\top \times A} = !_\top \circ \pi_1 = !_A \circ \pi_2$$

it follows that

$$\begin{array}{ccc} & \top \times A & \\ & \swarrow \quad \searrow & \\ !_A \circ \pi_2 & & 1_A \circ \pi_2 \\ & \langle !_A \circ \pi_2, 1_A \circ \pi_2 \rangle & \\ & \downarrow & \\ \top & \xleftarrow{\pi'_1} \top \times A \xrightarrow{\pi'_2} & A \end{array}$$

commutes, so by uniqueness follows $\langle !_A \circ \pi_2, 1_A \circ \pi_2 \rangle = !_\top \times 1_A$, and hence

$$\langle !_A, 1_A \rangle \circ \pi_2 = \langle !_A \circ \pi_2, 1_A \circ \pi_2 \rangle = !_\top \times 1_A = 1_\top \times 1_A = 1_{\top \times A}.$$

Similarly the components $\rho_A := \langle 1_A, !_A \rangle$ also define a natural isomorphism.

For associativity, let us fix some notation for the projections as

$$A \xleftarrow{\pi_1} A \times (B \times C) \xrightarrow{\pi_2} B \times C \quad \text{and} \quad B \xleftarrow{\pi'_1} B \times C \xrightarrow{\pi'_2} C$$

We define a morphism of type $A \times (B \times C) \rightarrow A \times B$ within

$$\begin{array}{ccc} & A \times (B \times C) & \\ & \swarrow \quad \searrow & \\ \pi_1 & & \pi'_1 \circ \pi_2 \\ & \langle \pi_1, \pi'_1 \circ \pi_2 \rangle & \\ & \downarrow & \\ A & \xleftarrow{\pi''_1} A \times B \xrightarrow{\pi''_2} & B \end{array}$$

and we define $\alpha_{A,B,C}$ within

$$\begin{array}{ccccc}
 & & A \times (B \times C) & & \\
 & \swarrow & \vdots & \searrow & \\
 & \langle \pi_1, \pi_1' \circ \pi_2 \rangle & & \langle \pi_2' \circ \pi_2 \rangle & \\
 & \swarrow & \langle \langle \pi_1, \pi_1' \circ \pi_2 \rangle, \pi_2' \circ \pi_2 \rangle & \searrow & \\
 A \times B & \xleftarrow{\pi_1'''} & (A \times B) \times C & \xrightarrow{\pi_2'''} & C
 \end{array}$$

Naturality as well as the fact that the components are isomorphisms relies on uniqueness of the morphisms as defined above and is left to the reader.

For symmetry the components $\sigma_{A,B} : A \times B \rightarrow B \times A$ are defined within

$$\begin{array}{ccccc}
 & & A \times B & & \\
 & \swarrow & \vdots & \searrow & \\
 & \pi_2 & \langle \pi_2, \pi_1 \rangle & \pi_1 & \\
 B & \xleftarrow{\pi_1'} & B \times A & \xrightarrow{\pi_2'} & A
 \end{array}$$

where again we leave verifications to the reader.

4.2 Copy-ability and delete-ability

So how does all this translate in term of morphisms as physical processes? By a *uniform copying operation* or *diagonal* in a monoidal category \mathbf{C} we mean a natural transformation

$$\Delta = \left\{ A \xrightarrow{\Delta_A} A \otimes A \mid A \in |\mathbf{C}| \right\}.$$

The corresponding commutativity requirement

$$\begin{array}{ccc}
 A & \xrightarrow{f} & B \\
 \Delta_A \downarrow & & \downarrow \Delta_B \\
 A \otimes A & \xrightarrow{f \otimes f} & B \otimes B
 \end{array}$$

now expresses that ‘when performing operation f on a system A and then copying it’ is the same as ‘copying system A and then performing operation f on each copy’. For example, correcting typos on a sheet of written paper and then Xeroxing it is the same as first Xeroxing it and then correcting the typos on each copy individually. The category \mathbf{Set} has

$$\{ \Delta_X : X \rightarrow X \times X :: x \mapsto (x, x) \mid X \in |\mathbf{Set}| \}$$

as a uniform copying operation since we have commutation of

$$\begin{array}{ccc} X & \xrightarrow{x \mapsto f(x)} & Y \\ \downarrow x \mapsto (x, x) & & \downarrow f(x) \mapsto (f(x), f(x)) \\ X \times X & \xrightarrow{(x, x) \mapsto (f(x), f(x))} & Y \times Y \end{array}$$

Do we have a uniform copying operation in **FdHilb**? We cannot just set

$$\Delta_{\mathcal{H}} : \mathcal{H} \rightarrow \mathcal{H} \times \mathcal{H} :: \psi \mapsto \psi \otimes \psi$$

since this map is not even linear. On the other hand, when for each Hilbert space \mathcal{H} a basis $\{|i\rangle\}_i$ is specified, we can consider

$$\{ \Delta_{\mathcal{H}} : \mathcal{H} \rightarrow \mathcal{H} \times \mathcal{H} :: |i\rangle \mapsto |i\rangle \otimes |i\rangle \mid \mathcal{H} \in |\mathbf{FdHilb}| \} .$$

But now the diagram

$$\begin{array}{ccc} \mathbb{C} & \xrightarrow{1 \mapsto |0\rangle + |1\rangle} & \mathbb{C} \oplus \mathbb{C} \\ \downarrow 1 \mapsto 1 \otimes 1 & & \downarrow \begin{array}{l} |0\rangle \mapsto |0\rangle \otimes |0\rangle \\ |1\rangle \mapsto |1\rangle \otimes |1\rangle \end{array} \\ \mathbb{C} \simeq \mathbb{C} \otimes \mathbb{C} & \xrightarrow{1 \otimes 1 \mapsto (|0\rangle + |1\rangle) \otimes (|0\rangle + |1\rangle)} & (\mathbb{C} \oplus \mathbb{C}) \otimes (\mathbb{C} \oplus \mathbb{C}) \end{array}$$

fails to commute since via one path we obtain the *Bell-state*

$$1 \mapsto |0\rangle \otimes |0\rangle + |1\rangle \otimes |1\rangle$$

while via the other path we obtain a *disentangled state*

$$1 \mapsto (|0\rangle + |1\rangle) \otimes (|0\rangle + |1\rangle) .$$

This inability to define a uniform copying operation reflects the fact that we cannot copy (unknown) quantum states.

Lets now turn our attention on **Rel** and consider the family of functions which provided a uniform copying operation for **Set**, given that every function is also a relation. In more typical relational notation we set

$$\Delta_X := \{ (x, (x, x)) \mid x \in X \} \subseteq X \times (X \times X) .$$

However, the diagram

$$\begin{array}{ccc}
 \{*\} & \xrightarrow{\{(*,0),(*,1)\}} & \{0,1\} \\
 \downarrow \{(*,(*,*)\} & & \downarrow \{(0,(0,0)),(1,(1,1))\} \\
 \{(*,*)\} = \{*\} \times \{*\} & \xrightarrow{\{(*,0),(*,1)\} \times \{(*,0),(*,1)\}} & \{0,1\} \times \{0,1\}
 \end{array}$$

fails to commute since via one path we have

$$\{(*, (0, 0)), (*, (1, 1))\} = \{*\} \times \{(0, 0), (1, 1)\}$$

while the other path yields

$$\{(*, (0, 0)), (*, (0, 1)), (*, (1, 0)), (*, (1, 1))\} = \{*\} \times (\{0, 1\} \times \{0, 1\}).$$

Note here in particular the similarity with the counterexample that we provided for the case of **FdHilb** when identifying

$$\begin{aligned}
 |0\rangle \otimes |0\rangle + |1\rangle \otimes |1\rangle &\xrightarrow{\cong} \{(0, 0), (1, 1)\} \\
 (|0\rangle + |1\rangle) \otimes (|0\rangle + |1\rangle) &\xrightarrow{\cong} \{0, 1\} \times \{0, 1\}.
 \end{aligned}$$

Similarly, the cobordism

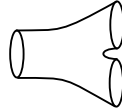

is not a component of a uniform copying relation

$$\{\Delta_n : n \rightarrow n + n \mid n \in \mathbb{N}\}$$

since in

$$\begin{array}{ccc}
 0 & \xrightarrow{\Delta_0} & 0 + 0 \\
 M \downarrow & & \downarrow M+M \\
 1 & \xrightarrow{\Delta_1} & 1 + 1
 \end{array}$$

where $M : 0 \rightarrow 1$ is



the upper path gives



while the lower path gives

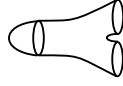

The fact that **Set** does admit a uniform copying operation is due to it being Cartesian together with the following general fact.

Proposition 5. *Each Cartesian category admits a uniform copying operation.*

Indeed, let

$$\Delta_A := \langle 1_A, 1_A \rangle$$

and $A \xrightarrow{f} B$ arbitrary. Then we have

$$\langle 1_B, 1_B \rangle \circ f = \langle 1_B \circ f, 1_B \circ f \rangle = \langle f \circ 1_A, f \circ 1_A \rangle = (f \times f) \circ \langle 1_A, 1_A \rangle.$$

so Δ is a natural transformation and hence a uniform copying operation.

In fact, one can define Cartesian categories in terms of the existence of a uniform copying operation and a corresponding uniform deleting operation

$$\mathcal{E} = \left\{ A \xrightarrow{\mathcal{E}_A} \mathbf{I} \mid A \in |\mathbf{C}| \right\}.$$

for which the naturality constraint now means that

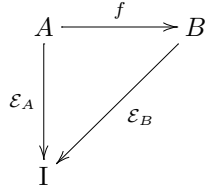

commutes. There are some additional constraints such as ‘first copying and then deleting results in the same as doing nothing’, and similar ones, which all together formally boil down to saying that for each object A in the category the triple $(A, \Delta_A, \mathcal{E}_A)$ has to be an *internal commutative comonoid*, a concept that we define below in Section 4.7.

Example 40. The fact that the diagonal in **Set** fails to be a diagonal in **Rel** seems to indicate that in **Rel** the Cartesian product does not provide a product in the sense of Definition 17. Consider

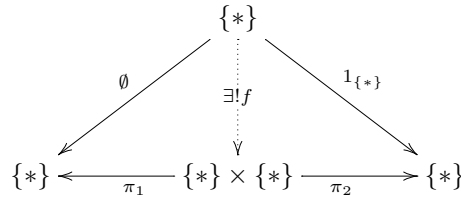

where \emptyset stands for the empty relation. Since $\{*\} \times \{*\} = \{(*, *)\}$ is a singleton there are only two possible choices for π_1 and π_2 namely the empty relation and the singleton relation $\{((*, *), *)\} \subseteq \{(*, *)\} \times \{*\}$. Similarly there are also only two candidate relations to play the role of f . So since $\pi_1 \circ f = \emptyset$ either π_1 or f has to be \emptyset and since $\pi_2 \circ f = 1_{\{*\}}$ neither π_2 nor f can be \emptyset . Thus π_1 has to be the empty relation and π_2 has to be the singleton relation. However, when considering

$$\begin{array}{ccccc}
 & & \{*\} & & \\
 & \swarrow & \vdots & \searrow & \\
 & 1_{\{*\}} & \exists! f & \emptyset & \\
 & \swarrow & \downarrow & \searrow & \\
 \{*\} & \xleftarrow{\pi_1} & \{*\} \times \{*\} & \xrightarrow{\pi_2} & \{*\}
 \end{array}$$

π_2 has to be the empty relation and π_1 has to be the singleton relation so we have a contradiction. Key to all this is the fact that the empty relation is a relation, while it is not a function, or more generally, that relations are *not total* (= each argument is not assigned to a value). On the other hand, when showing that the diagonal in **Set** was not a diagonal in **Rel** we relied on the multi-valuedness of the relation $\{(*, 0), (*, 1)\} \subseteq \{*\} \times \{0, 1\}$. Hence multi-valuedness of certain relations obstructs the existence of a natural diagonal in **Rel** while the lack of totality of certain relations obstructs the existence of faithful projections in **Rel**, causing a break-down of the Cartesian structure of \times in **Rel** as compared to the role it plays in **Set**.

4.3 Disjunction vs. conjunction

As we saw in Section 4.1, the fact that in **Set** Cartesian products $X \times Y$ consists of pairs (x, y) of elements $x \in X$ and $y \in Y$ can be expressed in terms of a bijective correspondence

$$\mathbf{Set}(C, A_1 \times A_2) \simeq \mathbf{Set}(C, A_1) \times \mathbf{Set}(C, A_2).$$

One can then naturally asks whether we also have that

$$\mathbf{Set}(A_1 \times A_2, C) \stackrel{?}{\simeq} \mathbf{Set}(A_1, C) \times \mathbf{Set}(A_2, C).$$

The answer is no. But we do have

$$\mathbf{Set}(A_1 + A_2, C) \simeq \mathbf{Set}(A_1, C) \times \mathbf{Set}(A_2, C).$$

where $A_1 + A_2$ is the disjoint union of two sets A_1 and A_2 , that is, we repeat,

$$A_1 + A_2 := \{(x_1, 1) \mid x_1 \in A_1\} \cup \{(x_2, 2) \mid x_2 \in A_2\}.$$

This isomorphism now involves *injection* maps

$$\iota_1 : A_1 \rightarrow A_1 + A_2 :: x_1 \mapsto (x_1, 1) \quad \text{and} \quad \iota_2 : A_2 \rightarrow A_1 + A_2 :: x_2 \mapsto (x_2, 2),$$

which include the respective elements which the disjoint union is made up from. Their action on hom-sets is

$$- \circ \iota_1 : \mathbf{Set}(A_1 + A_2, C) \rightarrow \mathbf{Set}(A_1, C) :: f \mapsto f \circ \iota_1$$

$$- \circ \iota_2 : \mathbf{Set}(A_1 + A_2, C) \rightarrow \mathbf{Set}(A_2, C) :: f \mapsto f \circ \iota_2,$$

which breaks a function which takes values either in A_1 *or* A_2 up in a function that takes values in A_1 and one that takes values in A_2 . We can again combine these two operations in a single one

$$\mathit{codec}_C^{A_1, A_2} : \mathbf{Set}(A_1 + A_2, C) \rightarrow \mathbf{Set}(A_1, C) \times \mathbf{Set}(A_2, C) :: f \mapsto (f \circ \iota_1, f \circ \iota_2)$$

which has an inverse, namely

$$\mathit{corec}_C^{A_1, A_2} : \mathbf{Set}(A_1, C) \times \mathbf{Set}(A_2, C) \rightarrow \mathbf{Set}(A_1 + A_2, C) :: (f_1, f_2) \mapsto [f_1, f_2]$$

where

$$[f_1, f_2] : A_1 + A_2 \rightarrow C :: \begin{cases} x \mapsto f_1(x) \text{ iff } x \in A_1 \\ x \mapsto f_2(x) \text{ iff } x \in A_2 \end{cases}$$

now recombines the two functions f_1 and f_2 into one. We have an isomorphism

$$\begin{array}{ccc} & \xrightarrow{\mathit{codec}_{\{*\}}^{A_1, A_2}} & \\ \mathbf{Set}(A_1 + A_2, C) & & \mathbf{Set}(A_1, C) \times \mathbf{Set}(A_2, C) \\ & \xleftarrow{\mathit{corec}_{\{*\}}^{A_1, A_2}} & \end{array}$$

Note that while $\langle f_1, f_2 \rangle$ produces an image either for the function f_1 or the function f_2 we have that $[f_1, f_2]$ produces an image both for the function f_1 and the function f_2 . In operational terms, while the product allows to assign a pair of states, the disjoint union allows to describe either of two possibilities, say a *branching structure* due to non-determinism.

Definition 20. A *coproduct* of two objects A_1 and A_2 in a category \mathbf{C} is a triple consisting of another object $A_1 + A_2 \in |\mathbf{C}|$ together with two morphisms

$$\iota_1 : A_1 \rightarrow A_1 + A_2 \quad \text{and} \quad \iota_2 : A_2 \rightarrow A_1 + A_2$$

which are such that the mapping

$$(- \circ \iota_1, - \circ \iota_2) : \mathbf{C}(A_1 + A_2, C) \rightarrow \mathbf{C}(A_1, C) \times \mathbf{C}(A_2, C)$$

admits an inverse for all $C \in |\mathbf{C}|$. A category \mathbf{C} is *co-Cartesian* if any pair of objects $A, B \in |\mathbf{C}|$ admits a (not necessarily unique) coproduct.

Again equivalently we also have the following variant.

Definition 21. A *coproduct* of two objects A_1 and A_2 in a category \mathbf{C} is a triple consisting of another object $A_1 + A_2 \in |\mathbf{C}|$ together with two morphisms

$$\iota_1 : A_1 \rightarrow A_1 + A_2 \quad \text{and} \quad \iota_2 : A_2 \rightarrow A_1 + A_2$$

such that for any object $C \in |\mathbf{C}|$, and any pair of morphisms $A_1 \xrightarrow{f_1} C$ and $A_2 \xrightarrow{f_2} C$ in \mathbf{C} , there exists a unique morphism $A_1 + A_2 \xrightarrow{f} C$ such that

$$f_1 = f \circ \iota_1 \quad \text{and} \quad f_2 = f \circ \iota_2.$$

We can again represent this in a commutative diagram, now

$$\begin{array}{ccc} & \forall C & \\ & \nearrow & \nwarrow \\ A_1 & \xrightarrow{\iota_1} & A_1 + A_2 \xleftarrow{\iota_2} & A_2 \\ & \searrow & \uparrow & \\ & & \exists! f & \end{array}$$

As a counterpart to the diagonal which we have in Cartesian categories we now have a *codiagonal*, with as components

$$\nabla_A := [1_A, 1_A] : A + A \rightarrow A.$$

Example 41. As explained in Example 14 we can think of a partially ordered set P as a category \mathbf{P} . In such a category products turn out to be *greatest lower bounds* or *meets* and coproducts turn out to be *least upper bounds* or *joins*. The existence of an isomorphism

$$\begin{array}{ccc} & \xrightarrow{\text{codec}_c^{a_1, a_2}} & \\ \mathbf{P}(a_1 + a_2, c) & & \mathbf{P}(a_1, c) \times \mathbf{P}(a_2, c), \\ & \xleftarrow{\text{corec}_c^{a_1, a_2}} & \end{array}$$

given that $\mathbf{P}(a_1 + a_2, c)$, $\mathbf{P}(a_1, c)$ and $\mathbf{P}(a_2, c)$ and hence also $\mathbf{P}(a_1, c) \times \mathbf{P}(a_2, c)$ are all either singletons or empty, means that $\mathbf{P}(a_1 + a_2, c)$ is non-empty if and only if $\mathbf{P}(a_1, c) \times \mathbf{P}(a_2, c)$, that is, if and only if both $\mathbf{P}(a_1, c)$ and $\mathbf{P}(a_2, c)$ are non-empty. Since non-emptiness of $\mathbf{P}(a, b)$ means that $a \leq b$ this indeed means that

$$a_1 + a_2 \leq c \iff a_1 \leq c \ \& \ a_2 \leq c$$

so $a_1 + a_2$ is indeed the least upper bounds of a_1 and a_2 . Definition 21 provides us with a complementary but equivalent definition of least upper bounds. In

$$\begin{array}{ccc} & \forall c & \\ & \nearrow & \nwarrow \\ a_1 & \xrightarrow{s.t. \leq} & a_1 + a_2 \xleftarrow{s.t. \geq} & a_2 \\ & \searrow & \uparrow & \\ & & \text{then } \vee & \end{array}$$

we now have that existence of ι_1 and ι_2 assert that $a_1 \leq a_1 + a_2$ and $a_2 \leq a_1 + a_2$, so $a_1 + a_2$ is an upper bound for a_1 and a_2 , and whenever there exists an element $c \in P$ which is such that both $a_1 \leq c$ and $a_2 \leq c$ hold, then we have that $a_1 + a_2 \leq c$, so $a_1 + a_2$ is indeed the upper bound for a_1 and a_2 .

Dually to what we did in a category with products, in a category with coproducts we can define sum morphisms $f + g$ in terms of commutation of

$$\begin{array}{ccccc}
 A_1 & \xrightarrow{\iota_1} & A_1 + A_2 & \xleftarrow{\iota_2} & A_2 \\
 \downarrow f & & \downarrow f + g & & \downarrow g \\
 B_1 & \xrightarrow{\iota'_1} & B_1 + B_2 & \xleftarrow{\iota'_2} & B_2
 \end{array}$$

and we have

$$h \circ [f, g] = [h \circ f, h \circ g] \quad \text{and} \quad [f, g] \circ (h + k) = [f \circ h, g \circ k],$$

and from these we can establish that coproducts provide a monoidal structure.

We already hinted at the fact that while a product can be interpreted as a conjunction, the coproduct can be interpreted as a disjunction. The law

$$A \text{ and } (B \text{ or } C) = (A \text{ and } B) \text{ or } (A \text{ and } C). \tag{35}$$

now translates in the fact that in a category which is both Cartesian and co-Cartesian there would exist a natural isomorphism

$$\{A \times (B + C) \xrightarrow{\text{dist}_{A,B,C}} (A \times B) + (A \times C) \mid A, B, C \in |\mathbf{C}|\},$$

something that we conveniently denote by

$$A \times (B + C) \simeq (A \times B) + (A \times C).$$

However, such an isomorphism does not always exist.

Example 42. Let \mathcal{H} be a Hilbert space and let $L(\mathcal{H})$ be the set of all of its (closed, in the infinite-dimensional case) subspaces ordered by inclusion. Again this can be thought of as a category \mathbf{L} . It has an initial object, namely the zero-dimensional subspace, and it has a terminal object, namely the whole Hilbert space itself. This category is Cartesian with intersection as product and it is also co-Cartesian for

$$V + W := \bigcap \{X \in L(\mathcal{H}) \mid V, W \subseteq X\},$$

that is, the (closed) linear span of V and W . However, as observed in [14], this lattice does not satisfy the distributive law. Take for example two vectors $\psi, \phi \in \mathcal{H}$ with $\phi \perp \psi$. Then

$$\text{span}(\psi + \phi) \cap (\text{span}(\psi) + \text{span}(\phi)) = \text{span}(\psi + \phi) \cap \text{span}(\psi, \phi) = \text{span}(\psi + \phi)$$

while

$$(\text{span}(\psi + \phi) \cap \text{span}(\psi)) \quad \text{and} \quad (\text{span}(\psi + \phi) \cap \text{span}(\phi))$$

only include the zero-vector, hence so does

$$(\text{span}(\psi + \phi) \cap \text{span}(\psi)) + (\text{span}(\psi + \phi) \cap \text{span}(\phi)),$$

and as a consequence

$$\begin{array}{c} \text{span}(\psi + \phi) \cap (\text{span}(\psi) + \text{span}(\phi)) \\ \Downarrow \\ (\text{span}(\psi + \phi) \cap \text{span}(\psi)) + (\text{span}(\psi + \phi) \cap \text{span}(\phi)) . \end{array}$$

What does always exist in a category which is both Cartesian and co-Cartesian is a natural transformation

$$\{(A \times B) + (A \times C) \xrightarrow{\theta_{A,B,C}} A \times (B + C) \mid A, B, C \in |\mathbf{C}|\},$$

which we conveniently denote by

$$(A \times B) + (A \times C) \rightsquigarrow A \times (B + C).$$

Indeed, by the assumption of being both Cartesian and co-Cartesian there exist unique morphisms f and g such that

$$\begin{array}{ccc} & A & \\ \pi_1 \nearrow & \uparrow f & \nwarrow \pi_2 \\ A \times B & \xrightarrow{\iota_1} (A \times B) + (A \times C) \xleftarrow{\iota_2} & A \times C \end{array}$$

and

$$\begin{array}{ccc} & B + C & \\ \iota_1 \circ \pi_2 \nearrow & \uparrow g & \nwarrow \iota_2 \circ \pi_2 \\ A \times B & \xrightarrow{\iota_1} (A \times B) + (A \times C) \xleftarrow{\iota_2} & A \times C \end{array}$$

namely $f := [\pi_1, \pi_2]$ and $g := [\iota_1 \circ \pi_1, \iota_2 \circ \pi_2]$, and hence there also exists a unique morphism h such that

$$\begin{array}{ccc} & (A \times B) + (A \times C) & \\ f \swarrow & \downarrow \theta_{A,B,C} & \searrow g \\ A & \xleftarrow{\pi_1} A \times (B + C) \xrightarrow{\pi_2} & B + C \end{array}$$

namely $\theta_{A,B,C} = \langle f, g \rangle = \langle [\pi_1, \pi_2], [\iota_1 \circ \pi_1, \iota_2 \circ \pi_2] \rangle$. From this it then also follows that in any lattice we have that

$$(a \wedge b) + (a \wedge c) \leq a \wedge (b + c).$$

The collection

$$\theta = \{\theta_{A,B,C} \mid A, B, C \in |\mathbf{C}|\}$$

is moreover a natural transformation since given

$$(f \times g) + (f \times h) : (A \times B) + (A \times C) \rightarrow (A' \times B') + (A' \times C')$$

we have, using the various lemmas for products and coproducts, that

$$\begin{aligned} & \langle [\pi_1, \pi_1], [\iota_1 \circ \pi_2, \iota_2 \circ \pi_2] \rangle \circ ((f, g) + (f, h)) \\ &= \langle [\pi_1, \pi_1] \circ (f \times g) + (f \times h), [\iota_1 \circ \pi_2, \iota_2 \circ \pi_2] \circ (f \times g) + (f \times h) \rangle \\ &= \langle [\pi_1 \circ (f \times g), \pi_1 \circ (f \times h)], [\iota_1 \circ \pi_2 \circ (f \times g), \iota_2 \circ \pi_2 \circ (f \times h)] \rangle \\ &= \langle [f \circ \pi'_1, f \circ \pi'_1], [\iota_1 \circ g \circ \pi'_2, \iota_2 \circ h \circ \pi'_2] \rangle \\ &= \langle f \circ [\pi'_1, \pi'_2], (g + h) \circ [\iota'_1 \circ \pi'_2, \iota'_2 \circ \pi'_2] \rangle \\ &= (f \times (g + h)) \circ \langle [\pi'_1, \pi'_2], [\iota'_1 \circ \pi'_2, \iota'_2 \circ \pi'_2] \rangle. \end{aligned}$$

which gives commutation of

$$\begin{array}{ccc} (A \times B) + (A \times C) & \xrightarrow{(f \times g) + (f \times h)} & (A' \times B') + (A' \times C') \\ \theta_{A,B,C} \downarrow & & \downarrow \theta_{A',B',C'} \\ A \times (B + C) & \xrightarrow{f \times (g+h)} & A' \times (B' + C') \end{array}$$

showing that θ is natural.

Whenever this natural transformation is a natural isomorphism we speak of a *distributive category*. The above analysis instantiates Birkhoff-von Neumann style quantum logic as category-theoretic.

4.4 Direct sums

Example 43. The *direct sum* $V \oplus V'$ of two vector spaces V and V' is both a product and a coproduct in $\mathbf{FdVect}_{\mathbb{K}}$. Indeed, consider matrices $M : V \rightarrow W$ and $N : V \rightarrow W'$ and the two matrices

$$\pi_1 := (1_W | 0_{W,W'}) \quad \pi_2 := (0_{W',W} | 1_{W'})$$

where 1_U denotes the identity on U and $0_{U,U'}$ is a matrix of 0's of dimension $\dim(U) \times \dim(U')$. The unique matrix P which makes

$$\begin{array}{ccccc}
 & & V & & \\
 & \swarrow & & \searrow & \\
 & M & & N & \\
 & \swarrow & & \searrow & \\
 W & & W \oplus W' & & W' \\
 \leftarrow & \pi_1 & & \pi_2 & \rightarrow
 \end{array}$$

commute is

$$\begin{pmatrix} M \\ N \end{pmatrix}.$$

Therefore \oplus is a product. Dually, when transposing all these matrices, i.e. the transpose of π_i becomes ι_i and the transpose of P becomes the matrix

$$(M|N),$$

then we have commutation of

$$\begin{array}{ccccc}
 W & \xrightarrow{\iota_1} & W \oplus W' & \xleftarrow{\iota_2} & W' \\
 & \searrow & & \swarrow & \\
 & M & & N & \\
 & \searrow & & \swarrow & \\
 & & V & & \\
 & & (M|N) & &
 \end{array}$$

showing that $W \oplus W'$ is indeed also a coproduct. Moreover, the zero-dimensional space is both initial and terminal.

Example 44. In the category **Rel** the disjoint union $+$ is on objects the same as in **Set** and its action on morphisms now extends to

$$R_1 + R_2 := \{(x, 1), (x', 1) \mid xR_1x'\} \cup \{(y, 2), (y', 2) \mid yR_2y'\}$$

for any two relations $R_1 : X \rightarrow X'$ and $R_2 : Y \rightarrow Y'$. We define the injection relations $\iota_1 : X \rightarrow X + Y$ and $\iota_2 : Y \rightarrow X + Y$ to be

$$\iota_1 := \{(x, (x, 1)) \mid x \in X\} \quad \text{and} \quad \iota_2 := \{(y, (y, 2)) \mid y \in Y\}$$

and the copairing relation $[R_1, R_2] : X + Y \rightarrow Z$ to be

$$[R_1, R_2] := \{(x, 1), z \mid xR_1z\} \cup \{(y, 2), z \mid yR_2z\}.$$

One easily verifies that all this defines a coproduct. When taking the relational converse of these injections to be projections, that is,

$$\pi_1 := \{(x, 1), x \mid x \in X\} \quad \text{and} \quad \pi_2 := \{(y, 2), y \mid y \in Y\}.$$

one also easily verifies that the disjoint union is at the same time a product. In fact, the diagrams expressing the product properties are converted into

the diagrams expressing the coproduct properties by the relational converse. Since for any $X \in |\mathbf{Rel}|$ there is only one relation of type

$$\emptyset \rightarrow X \quad \text{and} \quad X \rightarrow \emptyset$$

it follows that the empty set is both initial and terminal. This makes the disjoint union within \mathbf{Rel} quite similar to the direct sum in $\mathbf{FdVect}_{\mathbb{K}}$.

Definition 22. A *zero object* is an object which is both initial and terminal.

If a category \mathbf{C} has a zero object then for each pair of objects $A, B \in |\mathbf{C}|$ there exists a canonical map obtained by relying on the uniqueness of morphism from the initial and to the terminal object, namely

$$\begin{array}{ccc} & 0_{A,B} & \\ & \curvearrowright & \\ A & \longrightarrow 0 & \longrightarrow B \\ & \curvearrowleft & \end{array}$$

Definition 23. Let \mathbf{C} be a category with a *zero object*. Then the *direct sum* or *biproduct* of two objects $A_1, A_2 \in |\mathbf{C}|$ is a quintuple consisting of another object $A_1 \oplus A_2 \in |\mathbf{C}|$ together with four morphisms

$$\begin{array}{ccccc} & \iota_1 & & \iota_2 & \\ & \curvearrowright & & \curvearrowright & \\ A_1 & & A_1 \oplus A_2 & & A_2 \\ & \curvearrowleft & & \curvearrowleft & \\ & \pi_1 & & \pi_2 & \end{array}$$

satisfying

$$\begin{aligned} \pi_1 \circ \iota_1 &= 1_{A_1} & \pi_2 \circ \iota_1 &= 0_{A_1, A_2} \\ \pi_1 \circ \iota_2 &= 0_{A_2, A_1} & \pi_2 \circ \iota_2 &= 1_{A_2} . \end{aligned}$$

A *biproduct category* is a category in which for any two objects A_1 and A_2 a biproduct $(A_1 \oplus A_2, \pi_1, \pi_2, \iota_1, \iota_2)$ is specified.¹²

When setting

$$\delta_{ij} := \begin{cases} 1_{A_i} & i = j \\ 0_{A_j, A_i} & i \neq j \end{cases}$$

the above four equations can be conveniently written as

$$\pi_i \circ \iota_j = \delta_{ij} .$$

This definition does not seem to require that $A_1 \oplus A_2$ is both a product and a coproduct. In particular, it does not make any reference to other objects C as the definitions of product and a coproduct do. But one can show that it is equivalent to the following, which we took from [34].

¹²There is no particular reason why we ask for biproducts to be specified while in the case of Cartesian categories we only required existence. This is a matter of taste, whether one prefers ‘being Cartesian’ or ‘being a biproduct category’ to be conceived as a ‘property a category possesses’ or ‘some extra structure it comes with’. There are different ‘schools’ of category theory which have strong arguments for either of these. Therefore we decided to give an example of both.

Definition 24. Let \mathbf{C} both be Cartesian and be co-Cartesian with specified products and coproducts, let \perp be an initial object for \mathbf{C} and let \top be a terminal object for \mathbf{C} . Then \mathbf{C} is a *biproduct category* if

1. the (unique) morphism $\perp \longrightarrow \top$ is an isomorphism;
2. setting

$$A_1 \longrightarrow 1 \begin{array}{c} \xrightarrow{0_{A_1, A_2}} \\ \xrightarrow{\sim} \\ \xleftarrow{\sim} \end{array} 0 \longrightarrow A_2.$$

the morphism

$$[\langle 1_{A_1}, 0_{A_2, A_1} \rangle, \langle 0_{A_1, A_2}, 1_{A_2} \rangle] : A_1 + A_2 \rightarrow A_1 \times A_2$$

is an isomorphism for all objects $A_1, A_2 \in |\mathbf{C}|$.

Any morphism $A_1 + A_2 \xrightarrow{f} B_1 \times B_2$ is in fact fully characterised by the four other morphisms $f_{ij} := \pi_i \circ f \circ \iota_j$ for $i = 1, 2$ since we can recover f itself from these as

$$f = [\langle f_{1,1}, f_{2,1} \rangle, \langle f_{1,2}, f_{2,2} \rangle].$$

Indeed,

$$\begin{aligned} [\langle f_{1,1}, f_{2,1} \rangle, \langle f_{1,2}, f_{2,2} \rangle] &= [\langle \pi_1 \circ (f \circ \iota_1), \pi_2 \circ (f \circ \iota_1) \rangle, \langle \pi_1 \circ (f \circ \iota_2), \pi_2 \circ (f \circ \iota_2) \rangle] \\ &= [f \circ \iota_1, f \circ \iota_2] \\ &= f \circ [\iota_1, \iota_2] \\ &= f. \end{aligned}$$

Therefore it makes sense to think of f as the matrix

$$f = \begin{pmatrix} f_{1,1} & f_{1,2} \\ f_{2,1} & f_{2,2} \end{pmatrix}.$$

Condition 2 in Definition 24 can now be stated as the morphism

$$\begin{pmatrix} 1_{A_1} & 0_{A_2, A_1} \\ 0_{A_1, A_2} & 1_{A_2} \end{pmatrix}$$

having to be an isomorphism.

Example 45. In $\mathbf{FdVect}_{\mathbb{K}}$ the direct sum \oplus is a biproduct. We have

$$\pi_1 \circ \iota_1 = \pi_1 \circ \pi_1^T = (1_W | 0_{W, W'}) \begin{pmatrix} 1_W \\ 0_{W', W} \end{pmatrix} = 1_W.$$

We also have

$$\pi_1 \circ \iota_2 = \pi_1 \circ \pi_2^T = (1_W | 0_{W, W'}) \begin{pmatrix} 0_{W', W} \\ 1_{W'} \end{pmatrix} = 0_{W', W}.$$

The two remaining equations are obtained in the same manner.

Example 46. In **Rel** the disjoint union $+$ is a biproduct. The morphism

$$\pi_1 \circ \iota_1 : X \rightarrow X + Y \rightarrow X,$$

is a subset of $X \times X$. Since

$$\iota_1 = \{(x, (x, 1)) \mid x \in X\} \quad \text{and} \quad \pi_1 = \{((x, 1), x) \mid x \in X\}$$

their composite is $\{(x, x) \mid x \in X\}$, that is, 1_X . The morphism

$$\pi_1 \circ \iota_2 : Y \rightarrow X + Y \rightarrow X$$

is a subset of $X \times Y$, namely the set of pairs (x, y) such that there exists a $(x, z) \in \iota_2$ and $(z, x) \in \pi_1$. But there are no such elements z since the elements of X are labeled by 1 and those of Y by 2 within $X + Y$. Thus, the composite is the empty relation $0_{Y,X}$.

4.5 Categorical matrix calculus

By Definition 24 each biproduct category is Cartesian and hence it carries monoidal structure by Proposition 4. Moreover, each hom-set $\mathbf{C}(A, B)$ in a biproduct category \mathbf{C} is a monoid with

$$f + g := A \xrightarrow{\Delta_A} A \oplus A \xrightarrow{f \oplus g} B \oplus B \xrightarrow{\nabla_B} B$$

as the sum and $0_{A,B}$ as the unit. Indeed, let $f : A \rightarrow B$ and consider

$$f + 0_{A,B} = A \xrightarrow{\Delta_A} A \oplus A \xrightarrow{f \oplus 0_{A,B}} B \oplus B \xrightarrow{\nabla_A} B$$

The equality $f + 0_{A,B} = f$ can be shown via the commutation of

$$\begin{array}{ccccc}
 A & \xrightarrow{\Delta_A} & A \oplus A & \xrightarrow{f \oplus 0_{A,B}} & B \oplus B & \xrightarrow{\nabla_B} & B & (36) \\
 \downarrow \langle 1_A, 0_{A,0} \rangle & & \downarrow 1_{A \oplus 0_{A,0}} & & \uparrow 1_B \oplus 0_{0,B} & & \uparrow [1_B, 0_{0,B}] \\
 A & & A \oplus 0 & \xrightarrow{f \oplus 0_{0,0}} & B \oplus 0 & & B \\
 \downarrow \pi_1 & & \downarrow \pi_1 & & \uparrow \iota'_1 & & \uparrow 1_B \\
 A & \xrightarrow{f} & A & & B & & B
 \end{array}$$

In the above diagrams all subdiagrams commute by definition except the square at the bottom. To show that it commutes, consider

$$\begin{array}{ccccc}
A & \xleftarrow{\pi_1} & A \oplus 0 & \xrightarrow{\pi_1} & 0 \\
\downarrow f & & \downarrow f \oplus 0_{0,0} & & \downarrow 0_{0,0} \\
B & \xleftarrow{\pi'_1} & B \oplus 0 & \xrightarrow{\pi'_2} & 0
\end{array} \tag{37}$$

Since this is a product diagram, $f \oplus 0_{0,0}$ is the unique morphism making it commute. However, we also have that

$$\begin{array}{ccccc}
A & \xleftarrow{\pi_1} & A \oplus 0 & \xrightarrow{\pi_2} & 0 \\
\downarrow f & \searrow & \downarrow \pi_1 & \searrow & \downarrow 0_{0,0} \\
A & & A & & 0_{A \oplus 0,0} \\
\downarrow f & & \downarrow f & & \downarrow 0_{0,0} \\
B & \xleftarrow{\pi'_1} & B \oplus 0 & \xrightarrow{\pi'_2} & 0 \\
& & \downarrow \iota'_1 & & \\
& & B & &
\end{array}$$

showing that $\iota'_1 \circ f \circ \pi_1$ also makes diagram (37) commute. Thus, by uniqueness, we must have $f \oplus 0_{0,0} = \iota'_1 \circ f \circ \pi_1$, that is, the square at the bottom of diagram (36) also commutes. To establish $0_{A,B} + f$ one proceeds similarly.

We also have to show that we have $(f + g) + h = f + (g + h)$. This is established in terms of commutation of the diagram

$$\begin{array}{ccccccc}
A & \xrightarrow{\Delta_A} & A \oplus A & \xrightarrow{1_A \oplus \Delta_A} & A \oplus (A \oplus A) & \xrightarrow{(f+g) \oplus h} & (B \oplus B) \oplus B & \xrightarrow{1_B \oplus \nabla_B} & B \oplus B & \xrightarrow{\nabla_B} & B \\
& \searrow \Delta_A & & & \downarrow \alpha_{A,A,A} & & \downarrow \alpha_{B,B,B} & & \downarrow 1_B \oplus \nabla_B & & \downarrow \nabla_B \\
& & A \oplus A & & (A \oplus A) \oplus A & \xrightarrow{f \oplus (g+h)} & B \oplus (B \oplus B) & & & & \\
& & \downarrow \Delta_A \oplus 1_A & & & & & & & &
\end{array}$$

where $\alpha_{A,A,A}$ is defined as in Proposition 4. The central square commutes by definition. We now show that the left triangle also commutes. We have

$$\begin{aligned}
& \langle \langle \pi_1, \pi'_1 \circ \pi_2 \rangle, \pi'_2 \circ \pi_2 \rangle \circ (1_A \oplus \Delta_A) \circ \Delta_A \\
&= \langle \langle \pi_1, \pi'_1 \circ \pi_2 \rangle, \pi'_2 \circ \pi_2 \rangle \circ \langle 1_A, \langle 1_A, 1_A \rangle \rangle \\
&= \langle \langle \pi_1, \pi'_1 \circ \pi_2 \rangle \circ \langle 1_A, \langle 1_A, 1_A \rangle \rangle, \pi'_2 \circ \pi_2 \circ \langle 1_A, \langle 1_A, 1_A \rangle \rangle \rangle \\
&= \langle \langle \pi_1 \circ \langle 1_A, \langle 1_A, 1_A \rangle \rangle, \pi'_1 \circ \pi_2 \circ \langle 1_A, \langle 1_A, 1_A \rangle \rangle \rangle, \pi'_2 \circ \pi_2 \circ \langle 1_A, \langle 1_A, 1_A \rangle \rangle \rangle \\
&= \langle \langle 1_A, 1_A \rangle, 1_A \rangle \\
&= (\Delta_A \oplus 1_A) \circ \Delta_A .
\end{aligned}$$

The right triangle is also easily seen to commute.

This addition moreover satisfies a distributive law, namely

$$(f + g) \circ h = (f \circ h) + (g \circ h) \quad \text{and} \quad h \circ (f + g) = (h \circ f) + (h \circ g). \quad (38)$$

One usually refers to this as *enrichment in monoids*. We leave it up to the reader to verify these distributive laws. A physicist-friendly introduction to *enriched category theory* suitable for the readers of this chapter is [15]. An inspiring paper which introduced the concept is [43].

Proposition 6. *Let*

$$Q_i := \iota_i \circ \pi_i : A_1 \oplus A_2 \rightarrow A_1 \oplus A_2$$

for $i = 1, 2$. Then we have

$$\sum_{i=1,2} Q_i = 1_{A_1 \oplus A_2}.$$

Indeed, unfolding the definitions we have

$$\begin{aligned} \sum_{i=1,2} Q_i &= \nabla_{A_1 \oplus A_2} \circ ((\iota_1 \circ \pi_1) \oplus (\iota_2 \circ \pi_2)) \circ \Delta_{A_1 \oplus A_2} \\ &= \nabla_{A_1 \oplus A_2} \circ ((\iota_1 \oplus \iota_2) \circ (\pi_1 \oplus \pi_2)) \circ \Delta_{A_1 \oplus A_2} \\ &= (\nabla_{A_1 \oplus A_2} \circ (\iota_1 \oplus \iota_2)) \circ ((\pi_1 \oplus \pi_2) \circ \Delta_{A_1 \oplus A_2}) \end{aligned}$$

and using the fact that a biproduct of morphisms is at the same time a product of morphisms we obtain

$$(\pi_1 \oplus \pi_2) \circ \Delta_A = \langle \pi_1 \circ 1_{A_1}, \pi_2 \circ 1_{A_2} \rangle = \langle \pi_1, \pi_2 \rangle = 1_{A_1 \oplus A_2}.$$

Analogously, one obtains that $\nabla_A \circ (\iota_1 \oplus \iota_2) = 1_{A_1 \oplus A_2}$, and the composite of identities being again the identity, we proved the claim.

Definition 25. A *dagger biproduct category* is a category which is both a dagger symmetric monoidal category and a biproduct category with coinciding monoidal structures, and with $\iota_i = \pi_i^\dagger$ for all projections and injections.

These dagger biproduct categories were introduced in [2, 19, 58] in order to enable one to talk about quantum spectra in purely category-theoretic language. Let $A_1 \oplus A_2 \xrightarrow{U} B$ be unitary in a dagger biproduct category. By the corresponding *projector spectrum* we mean the family $\{P_i\}_i$ of *projectors*

$$P_i^U := U \circ Q_i \circ U^\dagger : B \rightarrow B.$$

Proposition 7. *Binary projector spectra satisfy*

$$\sum_{i=1,2} P_i^U = 1_B.$$

This result easily extends to more general biproducts $A_1 \oplus \dots \oplus A_n$ which can be defined in the obvious manner, and which allow us then to define n -ary projector spectra too. In Hilbert space this n -ary generalisation of Proposition 7 then corresponds to the fact that $\sum_{i=1}^{i=n} P_i = 1_{\mathcal{H}}$ where $\{P_i\}_{i=1}^{i=n}$ is the projector spectrum of an arbitrary self-adjoint operator. More details on this abstract view of quantum spectra are in [2, 19, 58].

Consider now two biproducts $A_1 \oplus \dots \oplus A_n$ and $B_1 \oplus \dots \oplus B_m$ each with their respective injections and projections. As already indicated in the previous section with each morphisms

$$A_1 \oplus \dots \oplus A_n \xrightarrow{f} B_1 \oplus \dots \oplus B_m$$

we can associate a matrix

$$\begin{pmatrix} \pi_1 \circ f \circ \iota_1 & \dots & \pi_1 \circ f \circ \iota_n \\ \vdots & \ddots & \vdots \\ \pi_m \circ f \circ \iota_1 & \dots & \pi_m \circ f \circ \iota_n \end{pmatrix}.$$

Moreover, these matrices obey the usual matrix rules with respect to composition and the above defined summation. Indeed, for composition, the composite $g \circ f = h$ also has an associate matrix with entries

$$h_{ij} = \pi_i \circ (f \circ g) \circ \iota_j.$$

By Proposition 6 we have

$$\begin{aligned} h_{ij} &= \pi_i \circ (f \circ g) \circ \iota_j \\ &= \pi_i \circ (f \circ 1 \circ g) \circ \iota_j \\ &= \pi_i \circ \left(f \circ \sum_r \iota'_r \circ \pi'_r \circ g \right) \circ \iota_j \\ &= \sum_r \pi_i \circ f \circ \iota'_r \circ \pi'_r \circ g \circ \iota_j \end{aligned}$$

from which we recover matrix multiplication. For the sum, using the distributivity of the composition over the sum, one finds that for individual entries on $f + g$ we have

$$\begin{aligned} \pi_i \circ (f + g) \circ \iota_j &= (\pi_i \circ f + \pi_i \circ g) \circ \iota_j \\ &= \pi_i \circ f \circ \iota_j + \pi_i \circ g \circ \iota_j \end{aligned}$$

which indeed is the sum of matrices.

Example 47. We illustrate the concepts of this section for the category **Rel**. Somewhat unfortunately the disjoint union bifunctor and the monoidal enrichment operation share the same notation $+$. However, since their types are very different i.e.

tensor $+$: $\mathbf{Rel}(X, Y) \times \mathbf{Rel}(X', Y') \rightarrow \mathbf{Rel}(X + X', Y + Y')$ and
 monoid $+$: $\mathbf{Rel}(X, Y) \times \mathbf{Rel}(X, Y) \rightarrow \mathbf{Rel}(X, Y)$,

respectively, this should not confuse the reader.

- The sum $R_1 + R_2 : X \rightarrow Y$ of two relations, by definition, is the composite

$$X \xrightarrow{\Delta_X} X + X \xrightarrow{R_1 + R_2} Y + Y \xrightarrow{\nabla_Y} Y.$$

The relation Δ_X consists of all pairs

$$\{(x, (x, 1)) \mid x \in X\} \cup \{(x, (x, 2)) \mid x \in X\}.$$

Thus the composite $(R_1 + R_2) \circ \Delta_X$ is then, by definition, the set

$$\{(x, (y, 1)) \mid xR_1y\} \cup \{(x', (y', 2)) \mid x'R_2y'\}.$$

Using the definition of copairing $\nabla_Y := [1_Y, 1_Y]$ we obtain

$$\{(x, y) \mid xR_1y\} \cup \{(x', y') \mid x'R_2y'\}$$

that is

$$R_1 + R_2 = \{(x, y) \mid xR_1y \text{ or } xR_2y\}.$$

- Relations

$$Q_X : X + Y \rightarrow X \rightarrow X + Y \quad \text{and} \quad Q_Y : X + Y \rightarrow Y \rightarrow X + Y$$

are defined as $\iota_X \circ \pi_X$ and $\iota_Y \circ \pi_Y$ respectively, that is,

$$\{((x, 1), (x, 1)) \mid x \in X\} \quad \text{and} \quad Q_Y = \{((y, 2), (y, 2)) \mid y \in Y\}.$$

Using the definition of the sum we obtain

$$\begin{aligned} Q_X + Q_Y &= \{((x, 1), (x, 1)) \mid x \in X\} \cup \{((y, 2), (y, 2)) \mid y \in Y\} \\ &= \{(\varphi, \varphi) \mid \varphi \in X + Y\} \\ &= 1_{X+Y} \end{aligned}$$

as required. It is easily seen that this generalises to an arbitrary number of terms in the biproduct.

- The matrix calculus in \mathbf{Rel} is done over the semiring (= rig = ring without inverses) \mathbb{B} of Booleans. The elements of this semiring, the two relations between $\{*\}$ and itself, that is, the empty relation and the identity relation, will be denoted by 0 and 1 respectively. The semiring operations on these arise from composing these relations (= semiring multiplication) and adding these relations (= semiring addition). We have distributivity by eqs.(38), and we then easily see that we indeed get the Boolean semiring:

$$0 \cdot 0 = 0 \quad 0 \cdot 1 = 0 \quad 1 \cdot 1 = 1 \quad 0 + 0 = 0 \quad 0 + 1 = 1 \quad 1 + 1 = 1$$

–contra the two-element field where we have $1 + 1 = 0$ – so the operations $-\cdot-$ and $-+-$ coincide with the Boolean logic operations:

$$\cdot \sim \wedge \quad \text{and} \quad + \sim \vee.$$

A relation $R : \{a, b\} \rightarrow \{c, d\}$ can now be represented 2×2 matrix e.g.

$$R = \begin{pmatrix} 1 & 1 \\ 1 & 0 \end{pmatrix}$$

for the case that aRc , bRc and aRd (and not bRd). Given another relation $R' : \{c, d\} \rightarrow \{e, f, g\}$ represented by

$$R' = \begin{pmatrix} 1 & 0 \\ 1 & 1 \\ 0 & 1 \end{pmatrix}$$

indicating that cRe , cRf , dRf and dRg , their composite

$$R' \circ R = \{(a, e), (a, f), (b, e), (b, f), (a, g)\}$$

can be computed by matrix multiplication:

$$\begin{pmatrix} 1 & 0 \\ 1 & 1 \\ 0 & 1 \end{pmatrix} \begin{pmatrix} 1 & 1 \\ 1 & 0 \end{pmatrix} = \begin{pmatrix} 1 & 1 \\ 1 & 1 \\ 1 & 0 \end{pmatrix}.$$

For a relation $R'' : \{a, b\} \rightarrow \{c, d\}$ represented by the matrix

$$\begin{pmatrix} 0 & 1 \\ 0 & 1 \end{pmatrix}$$

which indicates that $R'' = \{(b, c), (b, d)\}$ the sum $R + R''$ is given by

$$\{(a, c), (b, c), (a, d)\} \cup \{(b, c), (b, d)\} = \{(a, b), (a, c), (b, c), (b, d)\}$$

which indeed corresponds to the matrix sum

$$\begin{pmatrix} 1 & 1 \\ 0 & 1 \end{pmatrix} + \begin{pmatrix} 0 & 1 \\ 0 & 1 \end{pmatrix} = \begin{pmatrix} 1 & 1 \\ 1 & 1 \end{pmatrix}.$$

4.6 Quantum tensors from classical tensors

Interesting categories such as **FdHilb** and **Rel** have both classical-like and a quantum-like tensors. Obviously these two structures interact. For example, due to very general reasons we have distributivity natural isomorphisms

$$A \otimes (B \oplus C) \simeq (A \otimes B) \oplus (A \otimes C) \quad \text{and} \quad A \otimes 0 \simeq 0$$

both in the case of **FdHilb** and **Rel**. We can rely on so-called *closedness* of the \otimes -structure to prove this, something that we briefly address at the end of this chapter. Another manner to establish this fact for the cases of **FdHilb** and **Rel** is to observe that the \otimes -structure arises from the \oplus -structure.

Let \mathbf{C} be a biproduct category and let $X \in \mathbf{C}$ be such that composition commutes in $\mathbf{C}(X, X)$. Define a new category $\mathbf{C}|X$ as follows:

- The objects of $\mathbf{C}|X$ are those objects of \mathbf{C} which are of the form $\mathbf{I} \oplus \dots \oplus \mathbf{I}$. We denote such an object consisting of n terms by $[n]$.
- For all $n, m \in \mathbb{N}$ we set $\mathbf{C}|X([n], [m]) := \mathbf{C}([n], [m])$.

We moreover set:

- $\mathbf{I} := X$
- $[n] \otimes [m] := [n \times m]$
- We can represent all morphisms in $\mathbf{C}([n], [m])$ and hence also those in $\mathbf{C}|X([n], [m])$ by matrices. Given $f \in \mathbf{C}([n], [m])$ and $g \in \mathbf{C}([n'], [m'])$ we define $f \otimes g \in \mathbf{C}|X([n] \otimes [n'], [m] \otimes [m'])$ to be the morphism with

$$(f \otimes g)_{(i,i'),(j,j')} := f_{i,j} \circ g_{i',j'}$$

as its matrix entries.

This provides $\mathbf{C}|X$ with symmetric monoidal structure. We leave it to the reader to verify this. Note that commutativity of $\mathbf{C}(X, X)$ is necessary since otherwise we would be in contradiction with the fact that the scalar monoid in a monoidal category is always commutative –which was established in Section 2.5. With these definitions we now have that

$$[n] \otimes ([m] \oplus [k]) \simeq ([n] \otimes [m]) \oplus ([n] \otimes [k]) \quad \text{and} \quad [n] \otimes [0] \simeq [0].$$

Indeed, note first that since $[n] = \underbrace{\mathbf{I} \oplus \dots \oplus \mathbf{I}}_n$, then

$$[n] \oplus [m] \simeq [n + m]$$

which is $\underbrace{\mathbf{I} \oplus \dots \oplus \mathbf{I}}_{n+m}$. Therefore,

$$\begin{aligned} [n] \otimes ([m] \oplus [k]) &\simeq [n] \otimes [m + k] \\ &\simeq [n \times (m + k)] \\ &= [(n \times m) + (n \times k)] \\ &\simeq [n \times m] \oplus [n \times k] \\ &\simeq ([n] \otimes [m]) \oplus ([n] \otimes [k]). \end{aligned}$$

Moreover,

$$\begin{aligned} [n] \otimes [0] &\simeq [n \times 0] \\ &= [0]. \end{aligned}$$

When starting from **FdHilb** with $X = \mathbb{C}$ we obtain a category with objects of the form $\mathbb{C}^{\oplus n}$ for $n \in \mathbb{N}$, with linear maps between these as morphisms and with the usual space tensor product as the monoidal structure. When starting from **Rel** with $X = \mathbb{B}$ we obtain a category with objects of the form $\{*\} + \dots + \{*\}$, that is, a n -element set for each $n \in \mathbb{N}$, with relations between these as morphisms and with the Cartesian product as the monoidal structure.

Now set:

- $[n]^* := [n]$
- Let $\eta_{[n]} \in \mathbf{C}|X(\mathbb{I}, [n]^* \otimes [n])$ be the morphism with

$$(\eta_{[n]})_{(i,i),1} := 1_{\mathbb{I}} \quad \text{and} \quad (\eta_{[n]})_{(i,j \neq i),1} := 0_{\mathbb{I},\mathbb{I}}$$

as its matrix entries.

- Let $\epsilon_{[n]} \in \mathbf{C}|X([n] \otimes [n]^*, \mathbb{I})$ to be the morphism with

$$(\epsilon_{[n]})_{1,(i,i)} := 1_{\mathbb{I}} \quad \text{and} \quad (\epsilon_{[n]})_{1,(i,j \neq i)} := 0_{\mathbb{I},\mathbb{I}}$$

as its matrix entries.

This provides $\mathbf{C}|X$ with compact structure. Indeed, the identity of $[n]$ is

$$1_{[n]} = \delta_{i,j} := \begin{cases} 1_{\mathbb{I}} & \text{if } i = j \\ 0_{\mathbb{I},\mathbb{I}} & \text{otherwise} \end{cases}$$

Using this, we find that

$$(1_{[n]} \otimes \eta_{[n]})_{(i,(j,k)),(l,1)} = \delta_{i,l} \circ \eta_{(j,k),1}$$

and

$$(\epsilon_{[n]} \otimes 1_{[n]})_{(1,i),((j,k),l)} = \epsilon_{1,(j,k)} \circ \delta_{i,l}.$$

We can now verify the equations of compactness by computing the composite –say e – of the two preceding morphisms using matrix calculus i.e.:

$$e_{(m,n)} = \sum_{j,k,l} (\epsilon_{[n]} \otimes 1_{[n]})_{(1,m),((j,k),l)} (1_{[n]} \otimes \eta_{[n]})_{(j,(k,l)),(n,1)} \quad (39)$$

Note that the indexing over j , k and l has two different bracketings in the above sum. By definition of the identity, unit and counit, the term $e_{(m,n)}$ will be $1_{\mathbb{I}}$ only if $j = k = l$ which entails that $e_{(m,n)} = \delta_{i,j}$, the identity –since the objects are self-dual the other equation holds too.

Robin Houston proved a surprising result in [34] which to some extent is a converse to the above. It states that when a compact category is Cartesian (or co-Cartesian) then it also has direct sums.

4.7 Internal classical structures

In [2] Abramsky and one of the current authors used unitary biproduct decompositions of the form

$$U : A \rightarrow \underbrace{I \oplus \dots \oplus I}_n$$

to encode the flow of classical data in quantum informatic protocols. In **FdHilb** such a map indeed singles out a basis, namely, the linear maps

$$\{U^\dagger \circ \iota_i : \mathbb{C} \rightarrow \mathcal{H} \mid i = 1, \dots, n\}$$

defines a basis for the Hilbert space \mathcal{H} , the basis vectors being

$$\{|i\rangle := (U^\dagger \circ \iota_i)(1) \mid i = 1, \dots, n\}.$$

These basis vectors are then identified with outcomes of measurements.

But there is another way to encode bases as morphisms in a category for which we only need to rely on tensor structure, and hence can stay in the diagrammatic realm of Section 2.2. If we have a basis $\mathcal{B} := \{|i\rangle \mid i = 1, \dots, n\}$ of Hilbert space \mathcal{H} then we can consider the linear maps

$$\delta : \mathcal{H} \rightarrow \mathcal{H} \otimes \mathcal{H} :: |i\rangle \mapsto |ii\rangle \quad \text{and} \quad \epsilon : \mathcal{H} \rightarrow \mathbb{C} :: |i\rangle \mapsto 1$$

These two maps indeed faithfully encode the basis \mathcal{B} since we can extract it back from them. It suffices to solve the equation

$$\delta(|\psi\rangle) = |\psi\rangle \otimes |\psi\rangle$$

in unknown $|\psi\rangle$. Indeed, the only $|\psi\rangle$'s for which the right-hand-side will be of the form $|\phi_1\rangle \otimes |\phi_2\rangle$ will be the basis vectors since for any other $\psi = \sum_i \alpha_i |i\rangle$ we have that $\delta(|\psi\rangle) = \sum_i \alpha_i |i\rangle \otimes |i\rangle$, that is, a genuinely *entangled* state.

The pair of maps (δ, ϵ) satisfies several properties e.g.

$$(\delta \otimes 1_{\mathcal{H}}) \circ \delta = (1_{\mathcal{H}} \otimes \delta) \circ \delta : \mathcal{H} \rightarrow \mathcal{H} \otimes \mathcal{H} \otimes \mathcal{H} :: |i\rangle \mapsto |iii\rangle$$

and

$$(\epsilon \otimes 1_{\mathcal{H}}) \circ \delta = (1_{\mathcal{H}} \otimes \epsilon) \circ \delta = 1_{\mathcal{H}} :: |i\rangle \mapsto |i\rangle$$

establishing it as an instance of the following concept in **FdHilb**.

Definition 26. Let (\mathbf{C}, \otimes, I) be a monoidal category. Then an *internal comonoid* is an object $C \in |\mathbf{C}|$ together with a pair of morphisms

$$C \otimes C \xleftarrow{\delta} C \xrightarrow{\epsilon} I$$

where δ is the *comultiplication* and ϵ the *comultiplicative unit* such that

$$\begin{array}{ccc}
C & \xrightarrow{\delta} & C \otimes C \\
\delta \downarrow & & \downarrow 1_C \otimes \delta \\
C \otimes C & \xrightarrow{\delta \otimes 1_C} & C \otimes C \otimes C
\end{array}
\quad \text{and} \quad
\begin{array}{ccccc}
& & C & & \\
& \swarrow \cong & \downarrow \delta & \searrow \cong & \\
I \otimes C & \xleftarrow{\epsilon \otimes 1_C} & C \otimes C & \xrightarrow{1_C \otimes \epsilon} & C \otimes I
\end{array}$$

all commute.

Example 48. The relations

$$\delta = \{(x, (x, x)) \mid x \in X\} \subseteq X \times (X \times X)$$

and

$$\epsilon = \{(x, *) \mid x \in X\} \subseteq X \times \{*\}$$

define an internal comonoid on X in **Rel** as the reader may verify. We could refer to these as the *copying* and *deleting* relations.

The notion of internal comonoid is dual to the notion of *internal monoid*.

Definition 27. Let $(\mathbf{C}, \otimes, \mathbf{I})$ be a monoidal category. Then an *internal monoid* is an object $M \in |\mathbf{C}|$ together with a pair of morphisms

$$M \otimes M \xrightarrow{\mu} M \xleftarrow{e} \mathbf{I}$$

where m is the *multiplication* and e the *multiplicative unit* such that

$$\begin{array}{ccc}
M & \xleftarrow{\mu} & M \otimes M \\
\mu \uparrow & & \uparrow 1_M \otimes \mu \\
M \otimes M & \xleftarrow{\mu \otimes 1_M} & M \otimes M \otimes M
\end{array}
\quad \text{and} \quad
\begin{array}{ccccc}
& & M & & \\
& \swarrow \cong & \uparrow \mu & \nwarrow \cong & \\
I \otimes M & \xrightarrow{e \otimes 1_C} & M \otimes M & \xleftarrow{1_M \otimes e} & M \otimes I
\end{array}$$

all commute.

The origin of this name is the fact that monoids can equivalently be defined as internal monoids in **Set**. Since the notion of internal monoid applies to arbitrary monoidal categories it generalises the usual notion of a monoid.

Example 49. A strict monoidal category can equivalently be defined as an internal monoid in the category **Cat** which has categories as objects, functors as morphisms and the product of categories as tensor –see Section 5.1 below for a definition. Proving this is slightly beyond the scope of this chapter but we invite the interested reader to do so.

We now show that internal monoids in **Set** are indeed ordinary monoids. Given such an internal monoid (X, μ, e) in **Set**, where

$$\mu : X \times X \rightarrow X \quad \text{and} \quad e : \{*\} \rightarrow X$$

are now functions, we take the elements of the monoid to be those of the set X to be, the monoid operation to be

$$- \bullet - : X \times X \rightarrow X :: (x, y) \mapsto \mu(x, y)$$

and the unit of the monoid to be $1 := e(*) \in X$. The condition

$$\begin{array}{ccc} A \times A \times A & \xrightarrow{1_A \times \mu} & A \times A \\ \mu \times 1_A \downarrow & & \downarrow \mu \\ A \times A & \xrightarrow{\mu} & A \end{array}$$

boils down to the fact that for all $x, y, z \in X$ we have $x \bullet (y \bullet z) = (x \bullet y) \bullet z$, that is associativity of the monoid operation, and the condition

$$\begin{array}{ccccc} & & A & & \\ & \nearrow \simeq & \uparrow \mu & \nwarrow \simeq & \\ \{*\} \times A & \xrightarrow{e \times 1_A} & A \times A & \xleftarrow{1_A \times e} & A \times \{*\} \end{array}$$

boils down to the fact that for all $x \in X$ we have $x \bullet 1 = 1 \bullet x = x$, that is, the element 1 is the unit of the monoid.

Such an internal definition of a group requires a bit more work.

Definition 28. Let **C** be a category with finite products and \top be the terminal object in **C**. An *internal group* is an internal monoid (G, μ, e) together with a morphism $\text{inv} : G \rightarrow G$ such that

$$\begin{array}{ccc} G & \xrightarrow{!} & \top \\ \langle 1_G, \text{inv} \rangle \downarrow & & \downarrow e \\ G \times G & \xrightarrow{\mu} & G \\ \langle \text{inv}, 1_G \rangle \uparrow & & \uparrow e \\ G & \xrightarrow{!} & \top \end{array}$$

both commute.

The additional operation $\text{inv} : G \rightarrow G$ assigns the inverses of the group. We leave it to the reader to verify that internal groups in **Set** are indeed ordinary groups. When we rather consider groups in other categories, in particular those in categories of vector space, then one typically speaks about *quantum groups*. An excellent textbook on this topic is [61].

Also the notion of group homomorphism can be ‘internalized’ in a category. We define a *group homomorphisms* between two group objects (G, μ, e, inv) and $(G', \mu', e', \text{inv}')$ to be a morphism $\phi : G \rightarrow G'$ which commutes with all three structural morphisms, that is, the diagrams

$$\begin{array}{ccc}
 G \times G & \xrightarrow{\mu} & G \\
 \phi \times \phi \downarrow & & \downarrow \phi \\
 G' \times G' & \xrightarrow{\mu'} & G'
 \end{array}
 , \quad
 \begin{array}{ccc}
 \top & \xrightarrow{e} & G \\
 & \searrow \epsilon' & \downarrow \phi \\
 & & G'
 \end{array}
 \quad \text{and} \quad
 \begin{array}{ccc}
 G & \xrightarrow{\text{inv}} & G \\
 \phi \downarrow & & \downarrow \phi \\
 G' & \xrightarrow{\text{inv}'} & G'
 \end{array}$$

all commute. Again, this diagrams generalise what we know about group homomorphism, namely that they preserve multiplication, unit and inverses. The notion of (co)monoid homomorphism is defined analogously.

4.8 Diagrammatic classicality

In a dagger monoidal category every internal comonoid

$$(X, X \xrightarrow{\delta} X \otimes X, X \xrightarrow{\epsilon} I)$$

defines an internal monoid

$$(X, X \otimes X \xrightarrow{\delta^\dagger} X, I \xrightarrow{\epsilon^\dagger} X).$$

This is obvious from the equational constraints of course, and merely involves reversal of the arrows. But we can also easily encode this in diagrammatic terms. We will represent the comonoid multiplication and its unit as follows:

$$\delta := \begin{array}{c} \cup \\ \bullet \\ | \end{array}
 \quad
 \epsilon := \begin{array}{c} \bullet \\ | \end{array}$$

Then the corresponding requirements are:

$$\begin{array}{c} \cup \\ \bullet \\ \cup \\ \bullet \\ | \end{array}
 =
 \begin{array}{c} \cup \\ \cup \\ \bullet \\ | \end{array}
 \quad
 \begin{array}{c} \bullet \\ \cup \\ \bullet \\ | \end{array}
 =
 \begin{array}{c} | \\ | \end{array}
 =
 \begin{array}{c} \cup \\ \bullet \\ \cup \\ \bullet \\ | \end{array}$$

Now, if we flip all these upside-down we obtain a monoid:



and its corresponding requirements:



We can summarise all of this in the term *dagger (co)monoid*. The dagger comonoids in **FdHilb** and **Rel** which we have seen above both have some additional properties. For example, they are *commutative*:

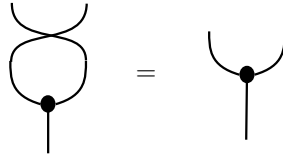

That is, symbolically, $\sigma_{X,X} \circ \delta = \delta$. Also, the comultiplication is *isometric* or *special*:

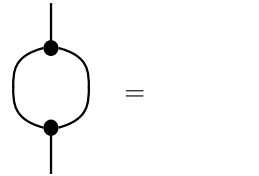

That is, symbolically, $\delta^\dagger \circ \delta = 1_X$. But by far, the most fascinating law which they obey is the *Frobenius equations*:

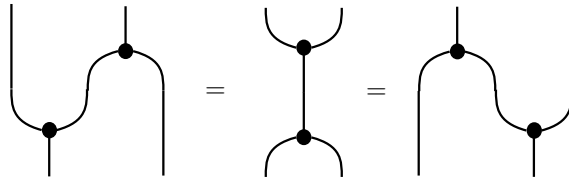

that is, symbolically,

$$(1_X \otimes \delta^\dagger) \circ (\delta \otimes 1_X) = \delta \circ \delta^\dagger = (\delta^\dagger \otimes 1_X) \circ (1_X \otimes \delta).$$

For a commutative dagger comonoid these two equations are easily seen to be equivalent. We verify that these equations hold for the dagger comonoids in **FdHilb** and **Rel** discussed in the previous section. In **FdHilb**, we have

$$\delta^\dagger : \mathcal{H} \otimes \mathcal{H} \rightarrow \mathcal{H} :: |ij\rangle \mapsto \delta_{ij} \cdot |i\rangle \quad \text{and} \quad \epsilon^\dagger : \mathbb{C} \rightarrow \mathcal{H} :: 1 \mapsto \sum_i |i\rangle$$

so

$$\begin{array}{ccccc} |ij\rangle & \xrightarrow{\delta \otimes 1_X} & |iij\rangle & \xrightarrow{1_X \otimes \delta^\dagger} & |i\rangle \otimes (\delta_{ij} \cdot |i\rangle) = \delta_{ij} \cdot |ii\rangle \\ |ij\rangle & \xrightarrow{\delta^\dagger} & \delta_{ij} \cdot |i\rangle & \xrightarrow{\delta} & \delta_{ij} \cdot |ii\rangle \end{array}$$

In **Rel** we have

$$\delta^\dagger = \{((x, x), x) \mid x \in X\} \subseteq (X \times X) \times X$$

and

$$\epsilon^\dagger = \{(*, x) \mid x \in X\} \subseteq \{*\} \times X$$

so we obtain

$$(1_X \otimes \delta^\dagger) \circ (\delta \otimes 1_X) = \delta \circ \delta^\dagger = \{((x, x), (x, x)) \mid x \in X\}.$$

One can show that the Frobenius equation together with isometry guarantees a normal form for any connected picture made up of dagger Frobenius (co)monoids, identities and symmetry, which only depends on the number of input and output wires –see for example [40, 21]. As a result we can represent any such network as a ‘spider’ e.g.:

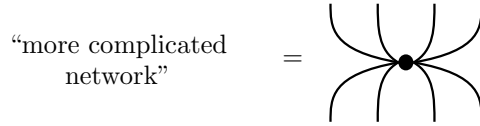

Hence commutative dagger special Frobenius comonoids turn out to be structures which come with a very simple calculus. But at the same time they are of key importance to quantum theory, as exemplified by this theorem due to Pavlovic, Vicary and one of the authors [24]:

Theorem 2. *In **FdHilb** there is bijective correspondence between dagger special Frobenius comonoids and orthonormal bases. Explicitly, each dagger special Frobenius comonoid in **FdHilb** is of the form*

$$\delta : \mathcal{H} \rightarrow \mathcal{H} \otimes \mathcal{H} :: |i\rangle \mapsto |ii\rangle \quad \text{and} \quad \epsilon : \mathcal{H} \rightarrow \mathbb{C} :: |i\rangle \mapsto 1$$

relative to some orthonormal basis $\{|i\rangle\}_i$.

The category **2Cob** also has morphism satisfying the Frobenius equation:

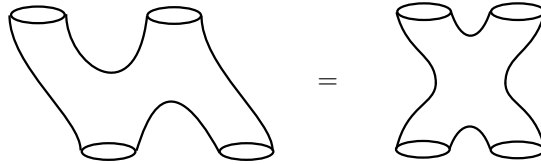

hence we still have a \dagger -Frobenius comonoid but it is not special; indeed, since following two cobordisms

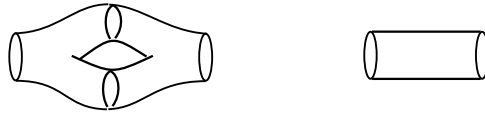

aren't homeomorphic, the comultiplication is not isometric. Hence, the representation of the normal form must preserve holes passing through the surface (i.e. it must preserve the *genus* of the surface). From this, a normal form in $\mathbf{2Cob}$ is of the form

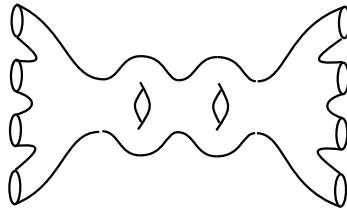

The commutative diagram in Definition 28 becomes

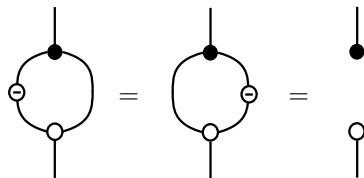

if we set

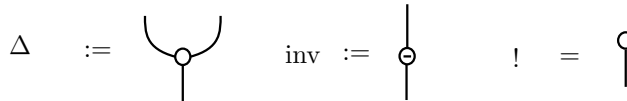

One refers to this picture typically as the *Hopf law*. What also holds for these operations are the *bialgebra laws*:

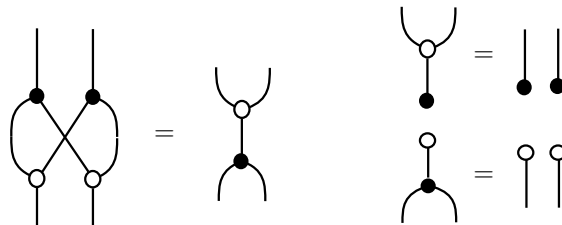

There's lots more on the connections between algebraic structures and these pictures in, for example, [39, 59, 61]. A great place to find some very well-explained introductions to this is John Baez' This Week's Finds in Mathematical Physics [8], for example, weeks 174, 224, 268.

5 Monoidal functoriality, naturality and TQFTs

In this section we provide the remaining bits of theory required to be able to state the definition of a topological quantum field theory.

5.1 Bifunctors

The category **Cat** which has categories as objects and functors as morphisms also comes with a monoidal structure.

Definition 29. The *product* of categories **C** and **D** is a category **C** × **D**:

1. objects are pairs (C, D) with $C \in |\mathbf{C}|$ and $D \in |\mathbf{D}|$;
2. morphisms are pairs $(f, g) : (C, D) \rightarrow (C', D')$ in **C** × **D** with

$$(f', g') \circ (f, g) = (f' \circ f, g' \circ g)$$

and the identities are pairs of identities.

This monoidal structure is Cartesian. The obvious projection functors

$$\mathbf{C} \xleftarrow{P_1} \mathbf{C} \times \mathbf{D} \xrightarrow{P_2} \mathbf{D}$$

provide the product structure encoded in:

$$\begin{array}{ccccc}
 & & \mathbf{E} & & \\
 & \swarrow \forall Q & & \searrow \forall R & \\
 & & \mathbf{C} \times \mathbf{D} & & \\
 & \swarrow P_1 & & \searrow P_2 & \\
 \mathbf{C} & & & & \mathbf{D}
 \end{array}$$

$\exists! F$ (vertical arrow from \mathbf{E} to $\mathbf{C} \times \mathbf{D}$)

This notion of product allows for a very concise definition of *bifactoriality*. A *bifunctor* is now nothing but an ordinary functor of type

$$F : \mathbf{C} \times \mathbf{D} \rightarrow \mathbf{E}.$$

So to say that a tensor is a bifunctor it now suffices to say that

$$- \otimes - : \mathbf{C} \times \mathbf{C} \rightarrow \mathbf{C}$$

is a functor. Indeed, this implies that we have

$$\otimes(\varphi \circ \xi) = \otimes(\varphi) \circ \otimes(\xi) \quad \text{and} \quad \otimes(1_{\Xi}) = 1_{\otimes(\Xi)}$$

for all morphisms φ, ξ and all objects Ξ in **C** × **C**, that is,

$$(g \circ f) \otimes (g' \circ f') = (g \otimes g') \circ (f \otimes f') \quad \text{and} \quad 1_A \otimes 1_B = 1_{A \otimes B}.$$

We give another example of bifunctor which is contravariant in the first variable and covariant in the second variable. This functor is key to the so-called *Yoneda Lemma*, which constitutes the core of many categorical constructs, for which we refer to the standard literature. For all $A \in |\mathbf{C}|$ let

$$\mathbf{C}(A, -) : \mathbf{C} \rightarrow \mathbf{Set}$$

be the functor which maps

1. each object $B \in |\mathbf{C}|$ to the set $\mathbf{C}(A, B) \in |\mathbf{Set}|$;
2. each morphism $g : B \rightarrow C$ to the function

$$\mathbf{C}(A, g) : \mathbf{C}(A, B) \rightarrow \mathbf{C}(A, C) :: f \mapsto g \circ f .$$

For all $C \in |\mathbf{C}|$ let

$$\mathbf{C}(-, C) : \mathbf{C}^{op} \rightarrow \mathbf{Set}$$

as the functor which maps

1. each object $A \in |\mathbf{C}|$ to the set $\mathbf{C}(A, C) \in |\mathbf{Set}|$;
2. each morphism $f : A \rightarrow B$ to the function

$$\mathbf{C}(f, C) : \mathbf{C}(B, C) \rightarrow \mathbf{C}(A, C) :: g \mapsto g \circ f .$$

One verifies that given any pair $f : A \rightarrow B$ and $h : C \rightarrow D$ the diagram

$$\begin{array}{ccc} \mathbf{C}(B, C) & \xrightarrow{\mathbf{C}(f, C)} & \mathbf{C}(A, C) \\ \mathbf{C}(B, h) \downarrow & & \downarrow \mathbf{C}(A, h) \\ \mathbf{C}(B, D) & \xrightarrow{\mathbf{C}(f, D)} & \mathbf{C}(A, D) \end{array}$$

commutes sending a given $g : B \rightarrow C$ to the composite $h \circ g \circ f : A \rightarrow D$. The bifunctor which unifies the above two functors is

$$\mathbf{C}(-, -) : \mathbf{C}^{op} \times \mathbf{C} \rightarrow \mathbf{Set}$$

which maps

1. each pair of object $(A, B) \in |\mathbf{C}|$ to the set $\mathbf{C}(A, B) \in |\mathbf{Set}|$;
2. each pair morphism $(f : A \rightarrow B, h : C \rightarrow D)$ to the function

$$\mathbf{C}(f, h) : \mathbf{C}(A, D) \rightarrow \mathbf{C}(C, B) :: g \mapsto h \circ g \circ f .$$

We can now identify:

$$\mathbf{C}(A, -) := \mathbf{C}(1_A, -) \quad \text{and} \quad \mathbf{C}(-, A) := \mathbf{C}(-, 1_A) .$$

All of the above functors are called *representable functors* since they enable us to represent objects and morphisms of any category as functors on the well-known category of sets and functions.

5.2 Naturality

We already encountered a fair number of examples of our restricted variant of natural isomorphisms, namely

$$I \otimes A \simeq A \simeq A \otimes I \quad , \quad A \otimes B \simeq B \otimes A \quad , \quad A \otimes (B \otimes C) \simeq (A \otimes B) \otimes C$$

and

$$A \times (B + C) \simeq (A \times B) + (A \times C) \quad ,$$

as well as some proper natural transformations, namely

$$A \rightsquigarrow A \times A \quad , \quad A + A \rightsquigarrow A$$

and

$$(A \times B) + (A \times C) \rightsquigarrow A \times (B + C) \quad .$$

What makes all of these special is that all of the above expressions only involve objects of the category \mathbf{C} without there being any reference to morphisms. This is not the case anymore for the general notion of natural transformations, which are in fact, structure preserving maps between functors.

Definition 30. Let $F, G : \mathbf{C} \rightarrow \mathbf{D}$ be functors. A *natural transformation*

$$\tau : F \Rightarrow G$$

consists of a family of morphisms

$$\{\tau_A \in \mathbf{D}(FA, GA) \mid A \in |\mathbf{C}|\}$$

which are such that the diagram

$$\begin{array}{ccc} FA & \xrightarrow{\tau_A} & GA \\ Ff \downarrow & & \downarrow Gf \\ FB & \xrightarrow{\tau_B} & GB \end{array}$$

commutes for any $A, B \in |\mathbf{C}|$ and any $f \in \mathbf{C}(A, B)$.

Example 50. Given vector spaces V and W then two group representations

$$\rho_1 : G \rightarrow \mathrm{GL}(V) \quad \text{and} \quad \rho_2 : G \rightarrow \mathrm{GL}(W)$$

are *equivalent* if there exists an isomorphism $\tau : V \rightarrow W$ so that for all $g \in G$,

$$\tau \circ \rho_1(g) = \rho_2(g) \circ \tau. \quad (40)$$

This isomorphism is a natural transformation. Indeed, taking the functorial point of view for the two representations above, we get two functors

$$\mathbf{G} \xrightarrow{R_{\rho_1}} \mathbf{FdVect}_{\mathbb{K}} \quad \text{and} \quad \mathbf{G} \xrightarrow{R_{\rho_2}} \mathbf{FdVect}_{\mathbb{K}}$$

where R_{ρ_1} maps $*$ on some vector space $R_{\rho_1}(*)$ and R_{ρ_2} maps $*$ on some vector space $R_{\rho_2}(*)$. Naturality means commutation of the following diagram:

$$\begin{array}{ccc} R_{\rho_1} (*) & \xrightarrow{\tau_*} & R_{\rho_2} (*) \\ R_{\rho_1} g \downarrow & & \downarrow R_{\rho_2} g \\ R_{\rho_1} (*) & \xrightarrow{\tau_*} & R_{\rho_2} (*) \end{array}$$

which translates into eq.(40).

Example 51. The family of canonical linear maps

$$\{\tau_V : V \rightarrow V^{**} \mid V \in \mathbf{FdVect}_{\mathbb{K}}\}$$

from a vector space to its double dual is a natural transformation

$$\tau : \mathbf{1}_{\mathbf{FdVect}_{\mathbb{K}}} \Rightarrow (-)^{**}$$

from the identity functor to the double dual functor. There is no natural transformation of type $\mathbf{1}_{\mathbf{FdVect}_{\mathbb{K}}} \Rightarrow (-)^*$ pointing to the fact that, while each finite dimensional vector space is isomorphic with its dual, there is no canonical isomorphism since constructing one depends on a choice of basis.

The fact that for $\mathbf{FdVect}_{\mathbb{K}}$ naturality indeed means basis independence can immediately be seen from the definition of naturality. In

$$\begin{array}{ccc} FV & \xrightarrow{\tau_V} & GV \\ Ff \downarrow & & \downarrow Gf \\ FV & \xrightarrow{\tau_V} & GV \end{array}$$

the linear map $f : V \rightarrow V$ can be interpreted as a change of basis, and then the linear maps $Ff : FV \rightarrow FV$ and $Gf : GV \rightarrow GV$ apply this change of basis to the expressions FV and GV respectively. Commutation of the above diagram then means that it makes no difference whether we apply τ_V before the change of basis or whether we apply it after the change of basis. Hence it asserts that τ_V is a basis independent construction.

5.3 Monoidal functors and natural transformations

We now define a concept which has appeared a few time in the presentation so far, the notion of monoidal functor. Unsurprisingly, it is a functor between two monoidal categories that preserves the monoidal structure ‘coherently’.

Definition 31. Let

$$(\mathbf{C}, \otimes, \mathbf{I}, \alpha_{\mathbf{C}}, \lambda_{\mathbf{C}}, \rho_{\mathbf{C}}) \quad \text{and} \quad (\mathbf{D}, \odot, \mathbf{J}, \alpha_{\mathbf{D}}, \lambda_{\mathbf{D}}, \rho_{\mathbf{D}})$$

be monoidal categories, then a *monoidal functor* is a functor

$$F : \mathbf{C} \rightarrow \mathbf{D}$$

together with a natural transformation

$$\{\phi_{A,B} : FA \odot FB \rightarrow F(A \otimes B) \mid A, B \in |\mathbf{C}|\}$$

and a morphism

$$\phi : \mathbf{J} \rightarrow F\mathbf{I}$$

which are such that for every $A, B, C \in \mathbf{C}$, the diagrams

$$\begin{array}{ccc} (FA \odot FB) \odot FC & \xrightarrow{\alpha_{\mathbf{D}}^{-1}} & FA \odot (FB \odot FC) \\ \phi_{A,B} \odot 1_{FC} \downarrow & & \downarrow 1_{FA} \odot \phi_{B,C} \\ F(A \otimes B) \odot FC & & FA \odot F(B \otimes C) \\ \phi_{A \otimes B, C} \downarrow & & \downarrow \phi_{A, B \otimes C} \\ F((A \otimes B) \otimes C) & \xrightarrow{F\alpha_{\mathbf{C}}^{-1}} & F(A \otimes (B \otimes C)) \end{array}$$

and

$$\begin{array}{ccc} FA \odot \mathbf{J} & \xrightarrow{1_{FA} \odot \phi} & FA \odot F\mathbf{I} \\ \rho_{\mathbf{D}}^{-1} \downarrow & & \downarrow \phi_{A, \mathbf{I}} \\ FA & \xleftarrow{F\rho_{\mathbf{C}}^{-1}} & F(A \otimes \mathbf{I}) \end{array} \quad , \quad \begin{array}{ccc} \mathbf{J} \odot FB & \xrightarrow{\phi \odot 1_{FB}} & F\mathbf{I} \odot FB \\ \lambda_{\mathbf{D}}^{-1} \downarrow & & \downarrow \phi_{\mathbf{I}, B} \\ FB & \xleftarrow{F\lambda_{\mathbf{C}}^{-1}} & F(\mathbf{I} \otimes B) \end{array}$$

commute. Moreover, a monoidal functor between symmetric monoidal categories is *symmetric* if, in addition, the following diagram

$$\begin{array}{ccc} FA \odot FB & \xrightarrow{\sigma_{FA, FB}} & FB \odot FA \\ \phi_{A, B} \downarrow & & \downarrow \phi_{B, A} \\ F(A \otimes B) & \xrightarrow{F\sigma_{A, B}} & F(B \otimes A) \end{array}$$

commutes in \mathbf{D} . A monoidal functor is *strong* if the components of the natural transformation ϕ as well as the morphism ϕ are isomorphisms, and it is *strict* if they are identities. In this case the equational requirements simplify to

$$F(A \otimes B) = FA \odot FB \quad \text{and} \quad FI = J,$$

and

$$F\alpha_{\mathbf{C}} = \alpha_{\mathbf{D}} \quad , \quad F\lambda_{\mathbf{C}} = \lambda_{\mathbf{D}} \quad , \quad F\rho_{\mathbf{C}} = \rho_{\mathbf{D}} \quad \text{and} \quad F\sigma_{\mathbf{C}} = \sigma_{\mathbf{D}}.$$

Hence a strict monoidal functor between strict monoidal categories just means that the tensor is preserved by F .

Example 52. The functor $\dagger : \mathbf{C}^{op} \rightarrow \mathbf{C}$ is a strict monoidal functor. In a compact category \mathbf{C} , the functor $(-)^* : \mathbf{C}^{op} \rightarrow \mathbf{C}$ which maps any object A on A^* and any morphism f on f^* is a strong monoidal functor.

Definition 32. A *monoidal natural transformation*

$$\theta : (F, \{\phi_{A,B} \mid A, B \in |\mathbf{C}|\}, \phi) \Rightarrow (G, \{\psi_{A,B} \mid A, B \in |\mathbf{C}|\}, \psi)$$

between two monoidal functors is a natural transformation such that

$$\begin{array}{ccc} FA \odot FB & \xrightarrow{\theta_A \odot \theta_B} & GA \odot GB \\ \phi_{A,B} \downarrow & & \downarrow \psi_{A,B} \\ F(A \otimes B) & \xrightarrow{\theta_{A \otimes B}} & G(A \otimes B) \end{array} \quad \text{and} \quad \begin{array}{ccc} & J & \\ \phi \swarrow & & \searrow \psi \\ FI & \xrightarrow{\theta_I} & GI \end{array}$$

A monoidal natural transformation is *symmetric* if the two monoidal functors which constitute its domain and codomain are both symmetric.

5.4 Equivalence of categories

In Example 6 we defined the category \mathbf{Cat} which has categories as objects and functors as morphism. Definition 2 on isomorphic objects, when applied to this special category \mathbf{Cat} , tells us two categories \mathbf{C} and \mathbf{D} are isomorphic if there exists two functors $F : \mathbf{C} \rightarrow \mathbf{D}$ and $G : \mathbf{D} \rightarrow \mathbf{C}$ such that $G \circ F = 1_{\mathbf{C}}$ and $F \circ G = 1_{\mathbf{D}}$. So the functor F defines a bijection between the objects as well as between the hom-sets of \mathbf{C} and \mathbf{D} . However, many categories that are for most practical purposes equivalent are not isomorphic. For example,

- the category \mathbf{FSet} which has all finite sets as objects, and functions between these sets as morphisms, and,
- a category which has for each $n \in \mathbb{N}$ exactly one set of that size as objects, and functions between these sets as morphisms.

Therefore it is useful to define some properties for functors that are weaker than being isomorphisms. For instance, the two following definitions describe functors whose morphism assignments are injective and surjective respectively.

Definition 33. A functor $F : \mathbf{C} \rightarrow \mathbf{D}$ is *faithful* if for any pair $A, B \in |\mathbf{C}|$ and any pair $f, f' : A \rightarrow B$, we have that

$$Ff = Ff' : FA \rightarrow FB \quad \text{implies} \quad f = f' : A \rightarrow B.$$

Definition 34. A functor $F : \mathbf{C} \rightarrow \mathbf{D}$ is *full* if for any pair $A, B \in |\mathbf{C}|$ and for any $g : FA \rightarrow FB$ there exists an $f : A \rightarrow B$ such that $Ff = g$.

A *subcategory* \mathbf{D} of a category \mathbf{C} is a collection of objects of \mathbf{C} as well as a collection of morphisms of \mathbf{C} such that

- for every morphism $f : A \rightarrow B$ in \mathbf{D} , both A and $B \in |\mathbf{D}|$;
- for every $A \in |\mathbf{D}|$, 1_A is in \mathbf{D} ;
- for every pair of composable morphisms f and g , $g \circ f$ is in \mathbf{D} .

These conditions entail that \mathbf{D} is itself a category. Moreover, if \mathbf{D} is a subcategory of \mathbf{C} , the inclusion functor $F : \mathbf{D} \rightarrow \mathbf{C}$ which maps every $A \in |\mathbf{D}|$ and $f \in \mathbf{D}$ to itself in \mathbf{C} is automatically faithful. If in addition F is full, then we say that \mathbf{D} is a *full subcategory* of \mathbf{C} . Note that in general, a full and faithful functor is *not yet* an isomorphism.

Definition 35. A functor $F : \mathbf{C} \rightarrow \mathbf{D}$ is an *equivalence of categories* when there is another functor $G : \mathbf{D} \rightarrow \mathbf{C}$ and natural isomorphisms

$$G \circ F \cong 1_{\mathbf{C}} \quad \text{and} \quad F \circ G \cong 1_{\mathbf{D}}.$$

An equivalence of categories is weaker than the notion of isomorphism of categories. It captures the essence of what we can do with categories without using concrete descriptions of objects: if two categories \mathbf{C} and \mathbf{D} are equivalent then any result following from the categorical structure in \mathbf{C} remains true in \mathbf{D} and vice-versa. We have [47]:

Theorem 3. *A functor $F : \mathbf{C} \rightarrow \mathbf{D}$ is an equivalence of categories if and only if it is both full and faithful, and if each object $B \in \mathbf{D}$ is isomorphic to an object FA for some $A \in |\mathbf{C}|$.*

Example 53. The *skeleton* \mathbf{D} of a category \mathbf{C} is any full subcategory of \mathbf{C} such that each object $A \in |\mathbf{C}|$ is isomorphic in \mathbf{C} to exactly one object $B \in |\mathbf{D}|$. An equivalence between these categories is then defined as follows. Since \mathbf{D} is a full subcategory of \mathbf{C} there is an inclusion functor $F : \mathbf{D} \rightarrow \mathbf{C}$. Now, for any $A \in |\mathbf{C}|$, we choose an isomorphism $\tau_A : A \rightarrow GA$ where $GA \in |\mathbf{D}|$. From this, there is a unique way to define a functor $G : \mathbf{C} \rightarrow \mathbf{D}$ such that $\tau : 1_{\mathbf{C}} \Rightarrow FG$ is a natural isomorphism with inverse $\tau^{-1} : GF \Rightarrow 1_{\mathbf{D}}$. Particular instances:

- The two categories with sets as objects and functions as morphisms discussed at the beginning of this section.
- **FdHilb** is equivalent to the category with $\mathbb{C}, \mathbb{C}^2, \dots, \mathbb{C}^n, \dots$ as objects and linear maps between these as morphisms. This category is isomorphic to the category $\mathbf{Mat}_{\mathbb{C}}$ of matrices with entries in \mathbb{C} of Example 18.

5.5 Topological quantum field theories

TQFTs are primarily used in condensed matter physics to describe, for instance, the fractional quantum Hall effect. Perhaps more accurately, TQFTs are quantum field theories that compute topological invariants. In the context of this paper, TQFTs are our main example of monoidal functors. Defining a TQFT as a monoidal functor is very elegant, however, the seemingly short definition that we will provide is packed with subtleties. In order to appreciate it to its full extent, we will first give the non-categorical axiomatics of a generic n -dimensional TQFTs as given in [62]. We then derive the categorical definition from it. The bulk of this section is taken from [39] to which the reader is referred for a more detailed discussion on the subject.

An n -dimensional TQFT is a rule \mathcal{T} which associates to each closed oriented $(n - 1)$ -dimensional manifold Σ a vector space $\mathcal{T}(\Sigma)$ over the field \mathbb{K} , and to each oriented cobordism $M : \Sigma_0 \rightarrow \Sigma_1$ a linear map $\mathcal{T}(M)$ from $\mathcal{T}(\Sigma_0)$ to $\mathcal{T}(\Sigma_1)$, subject to the following conditions:

1. if $M \simeq M'$ then $\mathcal{T}(M) = \mathcal{T}(M')$;
2. each cylinder $\Sigma \times [0, 1]$ is sent to the identity map of $\mathcal{T}(\Sigma)$;
3. If $M = M' \circ M''$ then

$$\mathcal{T}(M) = \mathcal{T}(M') \circ \mathcal{T}(M'');$$

4. the disjoint union $\Sigma = \Sigma' + \Sigma''$ is mapped to

$$\mathcal{T}(\Sigma) = \mathcal{T}(\Sigma') \otimes \mathcal{T}(\Sigma'');$$

and the disjoint union $M = M' + M''$ is mapped to

$$\mathcal{T}(M) = \mathcal{T}(M') \otimes \mathcal{T}(M'');$$

5. the empty manifold $\Sigma = \emptyset$ is mapped to the ground field \mathbb{K} and the empty cobordism is sent to the identity map on \mathbb{K} .

All of this can be written down in one line.

Definition 36. An n -dimensional TQFT is a symmetric monoidal functor

$$\mathcal{T} : (\mathbf{nCob}, +, \emptyset, T) \rightarrow (\mathbf{FdVect}_{\mathbb{K}}, \otimes, \mathbb{K}, \sigma)$$

where T is the twist map.

The rule that maps manifolds to vector spaces and cobordisms to linear maps gives the domain and the codomain of the functor. Condition 1 says that we consider homeomorphism classes of cobordisms. Conditions 2 and 3 spell out that the TQFT is a functor. Conditions 4 and 5 say that it is a monoidal functor. The main problem is now constructing such a functor. In the case of 2-dimensional quantum field theories, it turns out that this question can be answered with the material we introduced in the preceding sections.

We have the following result [39]:

Proposition 8. *The monoidal category $\mathbf{2Cob}$ is generated under composition and disjoint union by the following cobordisms:*

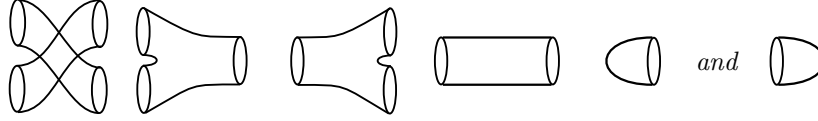

Following the discussion of Section 4.7, it is easily seen that these generators satisfy the axioms of a Frobenius comonoid. Moreover, since \mathcal{T} is a monoidal functor, it is sufficient to give the image of the generators of $\mathbf{2Cob}$ in order to specify it completely. Hence we can map this Frobenius comonoids in $\mathbf{2Cob}$ on a Frobenius comonoid in $\mathbf{FdVect}_{\mathbb{K}}$:

$$\begin{array}{ll}
 \text{Objects:} & n \mapsto \underbrace{V \otimes V \otimes \dots \otimes V}_{n \text{ times}} \\
 \text{Identity:} & \text{Cylinder} \mapsto 1_V : V \rightarrow V \\
 \text{Twist:} & \text{Twist} \mapsto \sigma_{V,V} : V \otimes V \rightarrow V \otimes V \\
 e: & \text{Cap} \mapsto e : \mathbb{K} \rightarrow V \\
 \mu: & \text{Cup} \mapsto \mu : V \otimes V \rightarrow V \\
 \epsilon: & \text{Cup} \mapsto \epsilon : V \rightarrow \mathbb{K} \\
 \delta: & \text{Cup} \mapsto \delta : V \rightarrow V \otimes V
 \end{array}$$

The converse is also true, that is, given a Frobenius comonoid on V , then we can define a TQFT with the preceding prescription, so there is a one-to-one correspondence between commutative Frobenius comonoids and 2-dimensional TQFTs. This is interesting in itself but we can go a step further.

We can now define the category $\mathbf{2TQFT}_{\mathbb{K}}$ of 2-dimensional TQFTs and symmetric monoidal natural transformation between them. Given two TQFTs $\mathcal{T}, \mathcal{T}' \in |\mathbf{2TQFT}_{\mathbb{K}}|$, then the components of the natural transformation θ must –by the definition above– be of the form

$$\theta_n : \underbrace{V \otimes V \otimes \dots \otimes V}_{n \text{ times}} \rightarrow \underbrace{W \otimes W \otimes \dots \otimes W}_{n \text{ times}}.$$

Since this natural transformation is monoidal, it is completely specified by the map $\theta_1 : V \rightarrow W$. The morphism $\theta_{\mathbb{K}}$ is the identity mapping from trivial Frobenius comonoid on \mathbb{K} to itself. Finally, naturality of θ means that the components must commute with the morphisms of $\mathbf{2Cob}$. Since the latter can be decomposed into the generators listed in Proposition 8, we just have to consider these cobordisms. For instance

$$\begin{array}{ccc}
 V \otimes V & \xrightarrow{\theta_2} & W \otimes W \\
 \mu_V \downarrow & & \downarrow \mu_W \\
 V & \xrightarrow{\theta_1} & W
 \end{array}$$

We can now define the category $\mathbf{CFC}_{\mathbb{K}}$ of commutative Frobenius comonoids and morphisms of Frobenius comonoids, that is, linear maps that are both comonoid homomorphisms and monoid homomorphisms.

Theorem 4. [39] *The category $\mathbf{2TQFT}_{\mathbb{K}}$ is equivalent to the category $\mathbf{CFC}_{\mathbb{K}}$.*

6 Further reading

The concept of *adjoint functors* (not to be confused with the above discussed dagger structure, namely, the abstract counterpart to linear algebraic adjoints) is, at least from a mathematical perspective, the greatest achievement of category theory thus far: it unifies essentially all known mathematical constructs of a variety areas of mathematics such as algebra, geometry, topology, analysis and combinatorics within a single mathematical concept.

The restriction of adjoint functors to posetal categories, that is, those discussed in Examples 14, 15, 41 and 42, is the concept of *Galois adjoints*. These play an important role in computer science when reasoning about *computational processes*. Let P be a partial order which represents the properties one wishes to attribute to the input data of a process, with ‘ $a \leq b$ ’ if and only if ‘whenever a holds then b must hold too’, and let Q be the partial order which represents the properties one wishes to attribute to the output data of that process. So the process is an order preserving map $f : P \rightarrow Q$. The order preserving map $g : Q \rightarrow P$, which maps a property b of the output to the ‘weakest’ property (i.e. highest in the partial ordering) which the input data needs to satisfy in order to guaranty that the output satisfies b , is then the *left Galois adjoint* to f . One refers to $g(b)$ as the *weakest precondition*. Formally f is left Galois adjoint to g if and only if for all $a \in P$ and all $b \in Q$ we have

$$f(a) \leq b \iff a \leq g(b).$$

The *orthomodular law* of quantum logic [54], that is, in the light of Example 42, a weakening of the distributive law which $L(\mathcal{H})$ does satisfy, is an example of such an adjunction of processes, namely

$$P_c(a) \leq b \iff a \leq [c \rightarrow](b)$$

where:

- P_c is an order-theoretic generalization of the linear algebraic notion of an ‘orthogonal projector on subspace c ’, formally defined to be

$$P_c : L \rightarrow L :: a \mapsto c \wedge (a \vee c^\perp),$$

- where $(-)^{\perp}$ stands for the orthocomplement ;
- $[- \rightarrow](-)$ is referred to as *Sasaki hook*, or unfortunately, also sometimes referred to as ‘quantum implication’, and is formally defined within

$$[c \rightarrow] : L \rightarrow L :: a \mapsto c^\perp \vee (a \wedge c).$$

Heyting algebras, that is, the order-theoretic incarnation of intuitionistic logic, and which play an important role in the recent work by Doering and Isham [28], are by definition Galois adjoints, now defined within

$$[c \wedge](a) \leq b \iff a \leq [c \Rightarrow](b).$$

So these Galois adjoints relate logical conjunction to logical implication.

The general notion of adjoint functors involves, instead of an ‘if and only if’ between statements $f(a) \leq b$ and $a \leq g(b)$, a ‘natural equivalence’ between hom-sets $\mathbf{D}(FA, B)$ and $\mathbf{C}(A, GB)$, where $F : \mathbf{C} \rightarrow \mathbf{D}$ and $G : \mathbf{D} \rightarrow \mathbf{C}$ are now functors. We refer to [4, 11] in these volumes for an account on adjoint functors and the role they play in logic. We also recommend [41] on this topic.

The composite $G \circ F : \mathbf{C} \rightarrow \mathbf{C}$ of a pair of adjoint functors is a *monad*, and each monad arises in this manner. The posetal counterpart to this is a *closure operator*, of which the linear span in a vector space is an example.

The composite $F \circ G : \mathbf{D} \rightarrow \mathbf{D}$ of a pair of adjoint functors is a *comonad*. Comonads are instance of what is referred to as *coalgebra*, of which comonoids are also an instance. The study of coalgebraic structures has become increasingly important both in computer science and physics. These structures are very different from algebraic structures: while algebraic structures typically would take two pieces of data a and b as input, and produce the composite $a \bullet b$, coalgebraic structures would do the opposite, that is, take one piece of data as input and produce two pieces of data as output, cf. a copying operation. Another example of a coalgebraic concept is quantum measurement. Quantum measurements take a quantum state as input and produces another quantum state together with classical data [23].

Finally we want to mention *higher-dimensional category theory*. Monoidal categories are a special case of *bicategories*, since we can compose the objects with the tensor, as well as the processes between these objects. There is currently much activity on the study of *n-categories*, that is, categories in which the hom-sets are themselves categories, and the hom-sets of these categories are again categories etc. Why would we be interested that? If one is interested in processes then one should also be in modifying processes, and that is exactly what these higher dimensional categorical structures enable to model. An excellent book on higher-dimensional category theory is [45].

References

1. S. Abramsky, *No-Cloning in categorical quantum mechanics*, in Semantic Techniques for Quantum Computation, I. Mackie and S. Gay (eds), to appear, Cambridge University Press, 2008.
2. S. Abramsky and B. Coecke, *A Categorical Semantics of Quantum Protocols*, in Proceedings of the 19th annual IEEE Symposium on Logic in Computer Science (LiCS'04), IEEE Computer Science Press, 2004. [arXiv:quant-ph/0402130](https://arxiv.org/abs/quant-ph/0402130) An updated & improved version appeared under the title *Categorical quantum mechanics*, in Handbook of quantum logic and quantum structures, Elsevier. [arXiv:0808.1023](https://arxiv.org/abs/0808.1023)
3. S. Abramsky and B. Coecke, *Abstract physical traces*. Theory and Application of Categories **14**, 111–124, 2006. <http://www.tac.mta.ca/tac/volumes/14/6/14-06abs.html>
4. S. Abramsky and N. Tzevelekos, *Introduction to categories and categorical logic*, in this volume entitled New Structures for Physics, Springer lecture Notes in Physics, 2008.
5. J. Adámek, H. Herrlich and G. E. Strecker, *Abstract and Concrete Categories – The Joy of Cats*. John Wiley and Sons, 1990. Freely available from <http://katmat.math.uni-bremen.de/acc/acc.pdf>
6. A. Asperti and G. Longo, *Categories, types, and Structures. An Introduction to Category theory for the Working Computer Scientist*. MIT Press, 1991.
7. H. Barnum, C. M. Caves, C. A. Fuchs, R. Jozsa, and B. Schumacher, *Noncommuting mixed states cannot be broadcast*. Physical Review Letters, **76**, 2818–2821, 1996. [arXiv:quant-ph/9511010](https://arxiv.org/abs/quant-ph/9511010)
8. J. C. Baez, This Week's Finds in Mathematical Physics, 1993–2008. <http://math.ucr.edu/home/baez/TWF.html>
9. J. C. Baez, *Quantum quandaries: A category-theoretic perspective*, in S. French et al. (Eds.) Structural Foundations of Quantum Gravity, Oxford University Press, 2004. [arXiv:quant-ph/0404040](https://arxiv.org/abs/quant-ph/0404040)
10. J. C. Baez and J. Dolan, *Higher-dimensional algebra and topological quantum field theory*. Journal of Mathematical Physics **36**, 60736105, 1995. [arXiv:q-alg/9503002](https://arxiv.org/abs/q-alg/9503002)
11. J. C. Baez and M. Stay, *Physics, topology, logic and computation: A Rosetta Stone*, in this volume entitled New Structures for Physics, Springer lecture Notes in Physics, 2008.
12. M. Barr and C. Wells, *Toposes, Triples and Theories*. Springer-Verlag, 1985. Republished in Reprints in Theory and Applications of Categories, No. 12, 1–287, 2005. <http://www.tac.mta.ca/tac/reprints/articles/12/tr12abs.html>
13. J. Bénabou, *Catégories avec multiplication*. Comptes Rendus des Séances de l'Académie des Sciences Paris **256**, 1887–1890, 1963.
14. G. Birkhoff and J. von Neumann, *The logic of quantum mechanics*. Annals of Mathematics **37**, 823–843, 1936.
15. F. Borceux and I. Stubbe. *Short introduction to enriched categories*, In Current Research in Operational Quantum Logic: Algebras, Categories and Languages, B. Coecke, D. J. Moore and A. Wilce (eds), pages 167–194. Fundamental Theories of Physics **111**, Springer-Verlag, 2000.
16. R. Brown, *Topology: A Geometric Account of General Topology, Homotopy Types, and the Fundamental Groupoid*. Halsted Press, 1988.

17. B. Coecke, *Kindergarten quantum mechanics*, in Quantum Theory: Reconsiderations of the Foundations III, A. Khrennikov (ed), pages 81–98, AIP Press, 2005. [arXiv:quant-ph/0510032v1](#)
18. B. Coecke, *Introducing categories to the practicing physicist*, in What is Category Theory? pages 45–74. Advanced Studies in Mathematics and Logic **30**, Polimetrica Publishing, 2006. [arXiv:0808.1032](#)
19. B. Coecke, *De-linearizing linearity: projective quantum axiomatics from strong compact closure*. Electronic Notes in Theoretical Computer Science **170**, 47–72, 2007. [arXiv:quant-ph/0506134](#)
20. B. Coecke and R. Duncan, *Interacting quantum observables*. In: Proceedings of the 35th International Colloquium on Automata, Languages and Programming, pages 298–310, Lecture Notes in Computer Science **5126**, Springer-Verlag, 2008.
21. B. Coecke and É. O. Paquette, *POVMs and Nairmarks theorem without sums*, Electronic Notes in Theoretical Computer Science (to appear), 2008. [arXiv:quant-ph/0608072](#)
22. B. Coecke, É. O. Paquette and D. Pavlovic, *Classical and quantum structuralism*, in Semantic Techniques for Quantum Computation, I. Mackie and S. Gay (eds), to appear, Cambridge University Press, 2008.
23. B. Coecke and D. Pavlovic, *Quantum measurements without sums*, In Mathematics of Quantum Computing and Technology, G. Chen, L. Kauffman and S. Lamonaco (eds), pages 567–604. Taylor and Francis, 2008. [arXiv:quant-ph/0608035](#)
24. B. Coecke, D. Pavlovic, and J. Vicary, *Commutative \dagger -Frobenius algebras in \mathbf{FdHilb} are bases*. Preprint, 2008.
25. P. Deligne, *Catégories tannakiennes*. In: The Grothendieck Festschrift Volume II, Progress in Mathematics **87**, pages 111–196, 1990. Birkhäuser.
26. D. G. B. J. Dieks, *Communication by EPR devices*. Physics Letters A **92**, 271–272, 1982.
27. P. A. M. Dirac, *The Principles of Quantum Mechanics (third edition)*. Oxford University Press, 1947.
28. A. Doering and C. Isham, ‘*What is a thing?*’: *Topos theory in the foundations of physics*, in the second part to these volumes entitled New Structures for Physics, Springer lecture Notes in Physics, 2008.
29. R. Duncan, *???*, in this volume entitled New Structures for Physics, Springer lecture Notes in Physics, 2008.
30. S. Eilenberg and S. MacLane, *General theory of natural equivalences*. Transactions of the American Mathematical Society, **58**, 231–294, 1945.
31. D. R. Finkelstein, J. M. Jauch, D. Schiminovich, and D. Speiser, *Foundations of quaternion quantum mechanics*. Journal of Mathematical Physics **3**, 207–220, 1962.
32. P. Freyd and D. Yetter, *Braided compact closed categories with applications to low-dimensional topology*. Advances in Mathematics **77**, 156–182, 1989.
33. J.-Y. Girard, *Linear logic*. Theoretical Computer Science **50**, 1–102, 1987.
34. R. Houston, *Finite products are biproducts in a compact closed category*. Journal of Pure and Applied Algebra **212**, 394–400, 2008. [arXiv:math/0604542](#)
35. A. Joyal and R. Street, *The geometry of tensor calculus I*. Advances in Mathematics **88**, 55–112, 1991.
36. A. Joyal, R. Street and D. Verity, *Traced monoidal categories*, Proceedings of the Cambridge Philosophical Society **119**, 447–468, 1996.

37. L. H. Kauffman, *Teleportation topology*. Optics and Spectroscopy **99**, 227–232, 2005. [arXiv:quant-ph/0407224](#)
38. G. M. Kelly and M. L. Laplaza, *Coherence for compact closed categories*. Journal of Pure and Applied Algebra **19**, 193–213, 1980.
39. J. Kock, *Frobenius Algebras and 2D Topological Quantum Field Theories*, London Mathematical Society, in Student Texts **59**, 2004.
40. S. Lack, *Composing PROPs*. Theory and Applications of Categories **13**, 147–163, 2004.
41. J. Lambek and P. J. Scott, *Higher Order Categorical Logic*. Cambridge University Press, 1986.
42. A. D. Lauda and H. Pfeiffer, *State sum construction of two-dimensional open-closed Topological Quantum Field Theories*, Journal of Knot Theory and its Ramifications **16**, 1121–1163, 2007.
43. F. W. Lawvere, *Metric spaces, generalized logic, and closed categories*. Rendiconti del Seminario Matematico e Fisico di Milano **43**, 135–166, 1974.
44. F. W. Lawvere and S. H. Schanuel, *Conceptual mathematics*. Cambridge University Press, 1997.
45. T. Leinster, *Higher Operads, Higher Categories*, London Mathematical Society Lecture Note Series 298, Cambridge University Press, 2004.
46. K. Martin and P. Panangaden, *Domain theory and general relativity*, in the second part to these volumes entitled New Structures for Physics, Springer lecture Notes in Physics, 2008.
47. S. Mac Lane, *Categories for the Working Mathematician* (second edition), Springer-Verlag, 2000.
48. R. F. Muirhead, *Some methods applicable to identities and inequalities of symmetric algebraic functions of n letters*. Proceedings of the Edinburgh Mathematical Society **21**, 144157, 1903.
49. M. A. Nielsen, *Conditions for a class of entanglement transformations*. Physical Review Letters **83**, 436–439, 1999.
50. S. E. Morrison. *A diagrammatic category for the representation theory of $U_q(\mathfrak{sl}_n)$* . PhD thesis, University of California at Berkeley, 2007.
51. A. K. Pati and S. L. Braunstein, *Impossibility of deleting an unknown quantum state*. Nature **404**, 164–165, 2000. [arXiv:quant-ph/9911090](#)
52. R. Penrose, *Applications of negative dimensional tensors*, in Combinatorial Mathematics and its Applications, 221–244, Academic Press, 1971.
53. R. Penrose, *Techniques of differential topology in relativity*, Society for Industrial and Applied Mathematics, 1972.
54. C. Piron, *Foundations of Quantum Physics*. W. A. Benjamin, 1976.
55. J. A. Robinson, *A machine-oriented logic based on the resolution principle*. Journal of the ACM **12**, 23–41, 1965.
56. R. Rosen, *Anticipatory Systems: Philosophical, Mathematical and Methodological Foundations*. Pergamon Press, 1985.
57. R. A. G. Seely, *Linear logic, *-autonomous categories and cofree algebras*. Contemporary Mathematics **92**, 371–382, 1998.
58. P. Selinger, *Dagger compact closed categories and completely positive maps*, Electronic Notes in Theoretical Computer Science **170**, 139–163, 2007.
59. P. Selinger, *A survey of graphical languages for monoidal categories*, in this volume entitled New Structures for Physics, Springer lecture Notes in Physics, 2008.

60. R. Sorkin, *Spacetime and causal sets*, In Relativity and Gravitation: Classical and Quantum, J. D'Olivo (ed), World Scientific, 1991.
61. R. Street, *Quantum Groups: A Path to Current Algebra*, Cambridge University Press, 2007.
62. V. G. Turaev, *Axioms for topological quantum field theories*, in Annales de la faculté des sciences de Toulouse 6^e série **3**, 135–152, 1994.
63. J. Vicary, *A categorical framework for the quantum harmonic oscillator*. International Journal of Theoretical Physics (to appear), 2008. [arXiv:quant-ph/0706.0711](#)
64. D. N. Yetter, *Functorial Knot Theory. Categories of Tangles, Coherence, Categorical Deformations, and Topological Invariants*, World Scientific, 2001.
65. W. Wootters and W. Zurek, *A single quantum cannot be cloned*. Nature **299**, 802–803, 1982.