

On the Non-Compositionality
of Monads
via Distributive Laws



Maaïke Zwart
Worcester College
University of Oxford

A thesis submitted for the degree of
Doctor of Philosophy

Trinity 2020

This thesis is dedicated to my parents

Tineke van Rijn and Jan Pieter Zwart

Thank you for fully supporting me in everything I do.

Acknowledgements

“If I have seen further it is by standing on the shoulders of Giants.”

– *Isaac Newton*

In his famous quote, Newton acknowledged the work of his predecessors, without which he could never have made his discoveries. As a direct academic descendant of Newton [46], I would like to acknowledge the giants on whose shoulders I stand: my teachers.

Isaac Newton → Roger Cotes → Robert Smith → Walter Taylor → Stephen Whisson → Thomas Postlethwaite → Tomas Jones → Adam Sedgwick → William Hopkins → George Stokes → John Strutt → Joseph Thomson → Paul Langevin → Louis de Broglie → Jules Géhéniau → Jean Reignier → Bob Coecke → me, where $n \rightarrow m$ iff ‘ m was a student of n ’.

First and foremost, I would like to thank my three supervisors Dan Marsden, Bob Coecke, and Jeremy Gibbons. Dan, even though you never became my official supervisor, I consider myself mostly a student of yours. You enthusiastically delved into this fascinating subject with me. During our collaborations you shared your expertise as a researcher, and taught me all the fine skills of the trade. You always put me and my career before your own, because you were more senior. You gave me ideas for thesis chapters long before I was even thinking about writing up. Thank you for everything you have given me. Bob, I know you highly value enthusiasm and creativity. Thank you for fuelling my passion and giving me the freedom to explore the subjects that sparked my interest, even though they did not always align with your own. Jeremy, thank you for the many fun iterations of the SEP Functional Programming module, and for all the advice, proof-reading, and help you have given me these past few years.

My supervisors are not the only teachers whose shoulders I stand on. I would like to mention a few of the teachers that have made a special contribution to my career, and to whom I owe great thanks. In university: Wim Veldman, whose love for logic and precision was so contagious that I

switched my focus from physics to mathematics. Bart Jacobs, who taught my first course in category theory. Benno van den Berg, who taught me how to ‘do’ category theory rather than just to read about it. Yde Venema, whose enthusiasm for teaching is something I will always remember. And Ina de Vries, for the many pep-talks that made me believe I could succeed in an academic career.

Even before starting university I have always been encouraged to explore my scientific interests. This is a privilege I have now discovered not all women are granted. I would like to thank Josephine Buskes, my high school maths teacher, for recognising the mathematician in me long before I considered mathematics a serious career option (I thought it was ‘just fun’ when I was a teenager). Marcel Koeneman for challenging me to look beyond the standard science material in school and question what I thought I knew about the world. And Mw. A. Jongen, who, when I loudly complained that her physics class was boring, organised for me to join a course at university rather than punishing me for disrupting her class. It was a brilliant move that sparked my still-flaming passion for physics.

There are so many others I would like to mention, but it is impossible to include everyone, since each of my teachers has had some influence on me in one way or another, and I am grateful for them all.

Last but not least of the giants then, I would like to thank my parents for being my greatest teachers of all. From teaching me the basic skills needed to function as a human being to taking me to science fairs and making ‘getting a book’ the reward for school achievements: you have taught me everything I know in life, including the value of science and education.

It is now time for me to become a giant and use my knowledge to help others grow. In the past five years, I have been an apprentice-giant (aka teaching assistant) for four courses of the Software Engineering Programme (SEP), as part of my TA-scholarship. I am eternally grateful to the SEP for sponsoring my DPhil through this scholarship, and for the wealth of teaching experience I gained while working with them.

I close these acknowledgements with a huge thanks to my fellow dwarves, my friends, who have helped keeping me sane by providing some much needed distractions. Especially all the wonderful people at Flight Club, thank you for all the hugs and laughs. You mean the world to me!

Abstract

Monads are a useful tool in both computer science and mathematics: they model computational behaviour, describe data structures, and give access to *Kleisli* and *Eilenberg-Moore* categories. To utilise multiple monads simultaneously, monads can sometimes be composed to form composite monads. *Distributive laws* ensure that such composite monads capture the full behaviour of both their components, creating a lifting of the component monads to the appropriate Kleisli or Eilenberg-Moore categories. However, for a given pair of monads there does not necessarily exist a distributive law to compose them.

This thesis presents a new method to prove so called *no-go theorems*: theorems that identify cases in which a distributive law cannot exist. The method, which uses an algebraic perspective on monads, has unique advantages over the more usual categorical approaches. The most important advantage is that it produces no-go theorems that identify large classes of monads that do not compose via distributive laws, where previously only a few specific counterexamples were known.

Among the many examples in this thesis, there are several that answer open questions from the literature, and some that identify previously unnoticed mistakes in the literature. Our no-go theorems will hopefully prevent these type of mistakes from happening in future.

Contents

1	Introduction	1
1.1	Historical Context	1
1.2	Personal Context	3
1.3	Prodding It with the Right Stick	4
1.4	Acknowledgement of Contributions	4
2	Background	6
2.1	String Diagrams	6
2.2	Monads and Distributive Laws	9
2.2.1	Monads	9
2.2.2	Distributive Laws	12
2.2.3	Iterated Distributive Laws	16
2.3	Algebraic Theories	18
2.4	Algebras and Algebras	21
2.4.1	Algebras for an Algebraic Theory	21
2.4.2	Algebras for a Monad	22
2.4.3	Algebras <i>are</i> Algebras	23
3	Composite Theories	26
3.1	The Constructive Connection	30
4	Characterising Idempotent Monads via Distributive Laws	42
4.1	Idempotent Monads	43
4.2	The Identity as Distributive Law	44
4.3	Two Other Extreme Cases of Distributive Laws	45

5	No-Go Theorems for Distributive Laws	48
5.1	Multiplicative Zeroes	49
5.2	Inverses and Absorption: Playing with Variables	55
5.2.1	No Distribution of Plus over Times	55
5.2.2	Generalisations	57
5.3	No-Go Theorems Based on Idempotence	63
5.3.1	The Original Counterexample	64
5.3.2	Generalising Plotkin’s Counterexample	66
5.3.3	Regarding Idempotency	75
5.3.4	Concerning Commutativity	80
5.4	No-Go Theorems Based on Units	87
5.4.1	The One Distributive Law, If It Exists	90
5.4.2	Lacking the Abides Property: a No-Go Theorem	100
5.4.3	Yet Another No-Go Theorem Caused by Idempotence	103
5.5	A Final Generalisation: Stable Universal Sets	106
6	The Boom Hierarchy: a Case Study for Distributive Laws	108
6.1	The Original Boom Hierarchy	109
6.2	The Extended Boom Hierarchy	110
6.3	Iterated Compositions	113
6.4	Self-Distribution	115
7	The Algebraic Method: a Reflection on our Techniques	118
7.1	The Algebraic Method: Techniques	118
7.2	Comparison to Categorical Methods	121
7.2.1	Monad and Distributive Law Axioms Algebraically	122
7.2.2	Algebraic Methods Categorically	124
7.2.3	Categorical Methods Algebraically	126
7.3	Regarding the Scope of Theorems	126
7.4	Regarding the Necessity of Reducing Terms to Variables in Proofs of No-Go Theorems	128
7.4.1	Conjectures	129
8	Conclusion	131
A	Notation	134
B	Proofs	135

Chapter 1

Introduction

This chapter discusses how the research presented in this thesis fits in both the wider programme of theoretical computer science and my own research programme. It also includes a note on the notation used in this thesis, and finishes with an acknowledgment of the contributions, both direct and indirect, that my collaborators have made to this thesis.

1.1 Historical Context

Monads are a key tool in computer science. They are, amongst other things, used to provide semantics for computational effects such as states, exceptions, and I/O [49]. They are also used to structure functional programs [51, 62], and appear explicitly in the standard library of the Haskell programming language [27]. As such, it is important to fully understand and characterise their behaviour.

Monads are a categorical concept. A monad on a category \mathcal{C} is a triple $\langle T, \eta, \mu \rangle$ consisting of an endofunctor $T : \mathcal{C} \rightarrow \mathcal{C}$ and two natural transformations $\eta : 1 \Rightarrow T$ and $\mu : T \circ T \Rightarrow T$ satisfying axioms described in Definition 2.1 below. A natural question to ask is whether two simple monads, each modelling a different computational effect, can be combined into a new monad modelling both computational effects simultaneously. Possible combinations of two monads include their direct sum, their tensor product, and their composition. Hyland, Plotkin and Power describe how to combine monads using sums and products [28]. In this thesis, we describe compositions of monads.

Unfortunately, composing the functor parts of two monads does not, in general, result in a new monad. Beck has shown that the existence of a *distributive law* provides sufficient (but not necessary) conditions for such a composition to form a monad [5]. A distributive law between monads S and T is a natural transformation

of type $S \circ T \Rightarrow T \circ S$, satisfying four equations described in Definition 2.10 below. This important idea has since been generalised to notions of distributive laws for combining monads with comonads, monads with pointed endofunctors, endofunctors with endofunctors and various other combinations, see for example the work by Lenisa *et al.* [39].

General-purpose techniques have been developed for constructing distributive laws [7, 15, 29, 44, 45]. These methods are highly valuable, for, in the words of Bonsangue *et al.*: “*It can be rather difficult to prove the defining axioms of a distributive law.*” [7]. In fact, it can be so difficult that on occasion a distributive law has been published which later turned out to be incorrect; Klin and Salamanca have made an overview of such cases involving the powerset monad [35].

The literature has tended to focus on positive results, either demonstrating specific distributive laws, or developing general-purpose techniques for constructing them. By comparison, there is a relative paucity of negative results, showing when no distributive law can exist. The most well-known result of this type appears in the paper *Distributing probability over non-determinism* [60], where it is shown that there is no distributive law combining the powerset and probability distribution monads, via a proof credited to Plotkin. This result was strengthened by Dahlqvist and Neves to show that the composite functor carries no monad structure at all [16]. Recently, the same proof technique was used by Klin and Salamanca to show that composing the covariant powerset functor with itself yields an endofunctor that does not carry any monad structure [35], correcting an earlier error in the literature [44].

In this thesis we present a new method for proving the absence of distributive laws, resulting in what we call *no-go theorems*. This terminology is borrowed from physics, where theorems proving impossibilities are called ‘no-go theorems’, because they clearly identify theoretical approaches that cannot succeed.

Our method uses an intimate connection between monads and universal algebra: for every monad there exists an algebraic theory and vice versa. We explain this connection in more detail in Section 2.4. Piróg and Staton extended this connection, showing that for every *composite monad* originating from a distributive law, there exists a *composite* algebraic theory [52]. By exploring the properties of these composite theories, and ultimately showing that some of them are inconsistent, we prove that certain distributive laws cannot exist. This algebraic approach has the advantage that it produces general theorems rather than specific counterexamples. As a result, our theorems apply to large classes of monads. We are hence able to significantly extend the current understanding of monad compositions via distributive laws.

There are many surprising results among the no-go theorems in this thesis. For instance, we prove that the list monad cannot distribute over itself, resolving an open question [44, 45] and previous error [34] in the literature. In addition, the no-go theorems reveal a previously unnoticed faulty distributive law in the literature, involving the list and exception monads [45].

We hope that by sharing these results our no-go theorems will live up to their name, and prevent others from wasting time on wild goose chases.

1.2 Personal Context

In this section, I would like to share the story of my DPhil, and how serendipity has led to the thesis that now lies before you.

Originally, I was investigating categorical models for natural language processing, in particular compositional distributional models of meaning (DisCoCat [14]). I was studying how density matrices from quantum physics could be used to model both homonyms and hyponyms, two different types of ambiguity in natural language [2, 64]. One of the major criticisms of this model is that it is not monadic, and therefore it lacks all the nice properties that monads have. So the question was whether the uncertainty of both hyponyms and homonyms could be captured in a monad, or a structure based on a monad.

I was inspired by a paper by Dan Marsden [47], who used the probability distribution monad to define an enriched category that could model either hyponyms or homonyms, but not both at the same time. My idea was to use his construction on the *double* probability distribution monad, which would result in an enriched category suitable to model *both* types of lexical ambiguity.

I quickly learned that monads do not automatically compose, and in fact, it was unknown whether the probability distribution monad could compose with itself. The result of my investigation into this ‘minor side question’ is this thesis. It turns out that the probability distribution monad does not compose with itself via a distributive law, as demonstrated in Example 5.22. This means that I cannot use the double distribution monad as I had hoped, to model both hyponyms and homonyms simultaneously.

There is much more to be discovered about monads and monad compositions, so I will continue this line of research. I leave the question of modelling ambiguity in natural language to a new generation of students.

1.3 Prodding It with the Right Stick

One of the most well-known applications of category theory is to provide a way to view mathematical objects from a different perspective. For example the famous Stone duality allows us to view Stone spaces as Boolean algebras and vice versa [31]. We will view monads from both a categorical and an algebraic perspective, making this thesis a prime example of applied category theory. The algebraic perspective turns out to be particularly useful for proving negative results, while the categorical perspective is better suited for positive results.

Apart from perspective, notation greatly influences how we think about mathematics. With the right notation, a multiple-page proof might be reduced to a single sentence, explainable in a pub. We will use string diagrams, commuting squares, and old fashioned algebra in our proofs, presenting each proof in the most suitable way.

1.4 Acknowledgement of Contributions

Most of the work presented in this thesis is my own original work, but of course I have not been working in complete isolation. My ideas are built on the work of others, and influenced by discussions with others. Where appropriate I give credit through the proper citations, but some influences cannot be indicated in this way, either because they are considered folklore or because they stem from informal discussions. In addition, some previously unpublished work from collaborators has found its way into this thesis. Without these contributions, the story presented here would not have been complete. I am grateful for my collaborators' permission to include their work in my thesis. In this section, I acknowledge all such contributions.

Ch 2: Any examples in this background chapter that are given without source are considered well-known to the community.

Ch 3: In this chapter, I build on the ideas from Maciej Piróg and Sam Staton presented in their paper "*Backtracking with cut via a distributive law and left-zero monoids*" [52], where they define the concept of a *composite theory*. Definition 3.2 is based on their Definition 3. Theorems 3.7 and 3.9 are constructive versions of their Theorem 5, so although the statement that distributive laws correspond one-to-one to composite theories was already known by Piróg and Staton, the method and proof of how to construct one from the other is new. The idea of Proposition 3.5 was formulated by Dan Marsden, although the proof is my

own. The proof of Proposition 3.4, in particular the implication $2 \Rightarrow 3$, was done collaboratively by Marsden and me.

Ch 4: This chapter is entirely my own work, although I owe great thanks to Marsden for pointing out its significance to me.

Ch 5: The original proof that the powerset monad does not distribute over the distribution monad, presented in Counterexample 5.18, is by Gordon Plotkin [60]. The idea of using universal algebra rather than categorical methods to prove such negative results was Marsden's. He was the first to try Plotkin's argument algebraically, and he convinced me to translate my own proofs to algebra, making them more convincing. The proofs of Theorem 5.20, Lemma 5.24, and Theorem 5.25 were all found by Marsden. Louis Parlant has been a great help in analysing Ernie Manes's and Philip Mulry's papers, especially the proof of Theorem 4.6 in *Monad Compositions II* [45]. This theorem clashes with some of our own results, and Parlant found the likely cause of this clash in the proof of one of the lemmas in the same paper. Bartek Klin pointed out that although the list monad does not distribute over itself, the composite functor LL does carry a monad structure (see Remark 5.44). The idea of *stable universal sets* was again formulated by Marsden. It captures why Theorem 5.20 can be applied to the distribution monad, but not to the group monad. This was an important step in our initial understanding of the range of applicability of our theorems.

Chapter 2

Background

We assume the reader has a basic knowledge of category theory. In particular, we assume that the concepts *category*, *functor*, and *natural transformation* are all familiar. More information on these can be found in standard textbooks on category theory, e.g. [1, 4, 41].

The core concepts of this thesis are monads, distributive laws, and algebraic theories. In this chapter we give the standard definitions of these concepts, introduce the notation we will use for them, and explain the relations between them.

We start this chapter with a brief reminder of string diagrams, a graphical notation for category theory, which we shall use in some of the proofs in this thesis.

2.1 String Diagrams

String diagrams represent category-theoretical concepts using lines ('strings') and boxes. This notation is particularly useful to study the structure of complicated expressions or equations involving several natural transformations. It also makes these expressions and equations easy to manipulate. This section briefly reminds the reader of the basics of string diagrams, focussing on the aspects that are important for this thesis. It is not meant to be a full introduction to string diagrams. For a more complete explanation and rigorous definitions of string diagrams we refer the reader to the Rosetta Stone paper by Baez and Stay [3] or the survey of graphical languages by Selinger [56]. We also recommend the Youtube channel 'TheCatsters' as an excellent introduction to various categorical concepts, including string diagrams, monads and distributive laws [10].

In **Cat**, the category of categories, categories (the objects) are often drawn as (labelled) points, functors (the morphisms) as arrows and natural transformations (morphisms between morphisms) as areas indicated by double arrows between arrows.

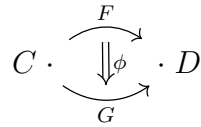

That is, categories are drawn as zero dimensional things, functors get one dimension and natural transformations two dimensions.

String diagrams reverse this order, having natural transformations as points (zero dimensional), functors as lines (one dimensional) and categories as areas (two dimensional). In topology, this is called the *Poincaré dual* [25].

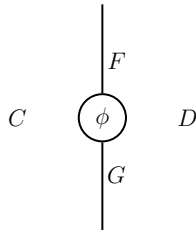

Composition of functors is drawn horizontally, while natural transformations can be composed horizontally and vertically. This is illustrated by the following string diagram:

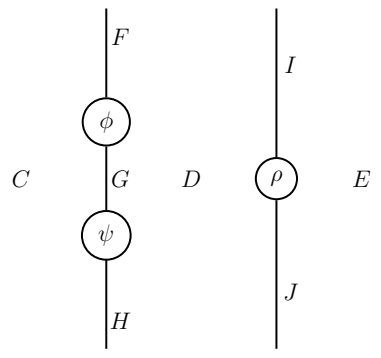

which represents:

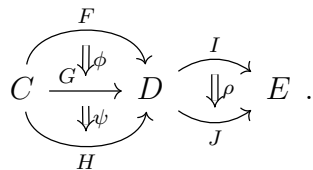

Notice that we expect the diagrams to be read from top to bottom. In the picture above, $\psi \circ \phi$ is drawn with ϕ on top, as that is the first natural transformation applied.

In string diagrams, only the topology of the diagram matters. Lines can bend, nodes can be dragged along lines, etc.

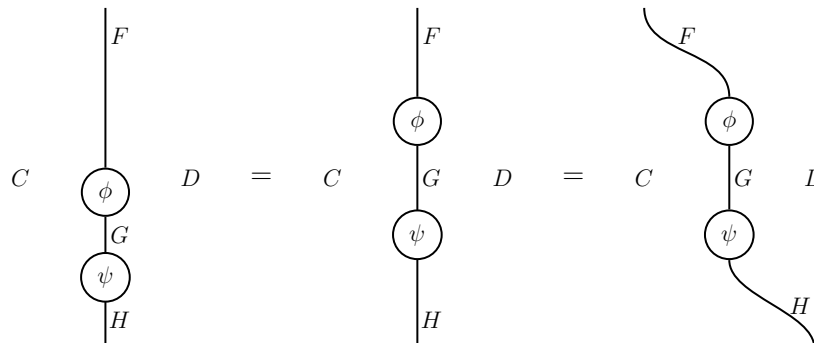

But nodes cannot, in general, slide past each other as this changes the meaning of the diagram.

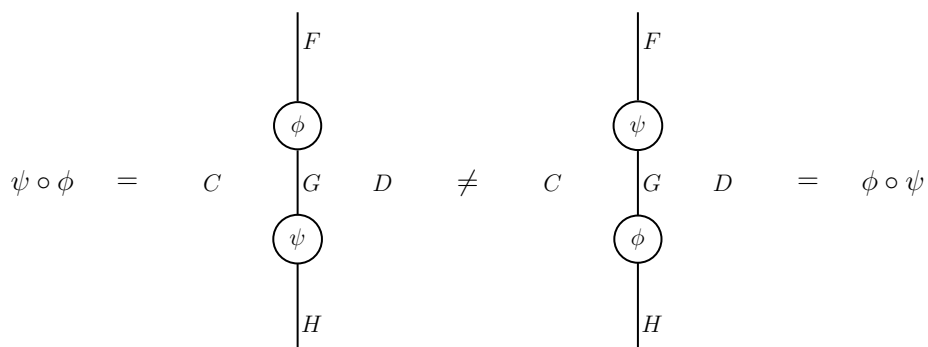

When the types of the categories, functors, and natural transformations in a string diagram are clear from the context, we omit their labels to make the picture less cluttered. In addition, we draw the identity functor as an invisible line. So a natural transformation $\eta : Id \Rightarrow F$ between the identity functor and an endofunctor $F : C \rightarrow C$ will simply be drawn as:

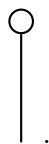

In the following sections, we shall give the definitions of various concepts both in the usual categorical notation and using string diagrams, whenever appropriate. Chapter 4 contains several short proofs using string diagrams.

2.2 Monads and Distributive Laws

We introduce monads and show how they can be composed using distributive laws. There are several equivalent definitions of monads, and each community has their own standard form. Category theorists generally prefer the *monoid* form, while functional programmers are more likely to use monads in *Kleisli* form. The monoid form is the most convenient for the purposes of this thesis, so that is the one we will introduce here. More information about the Kleisli form and the connection between the two formulations can be found in *Algebraic Theories* by Manes [42].

2.2.1 Monads

Monads are used in both mathematics and computer science. In mathematics, they are studied for their nice properties, in much the same way as groups and categories themselves are. In computer science, monads are used to model data structures and computational effects.

Definition 2.1 (Monads). A **monad** on a category \mathcal{C} is a triple $\langle T, \eta, \mu \rangle$ consisting of an endofunctor $T : \mathcal{C} \rightarrow \mathcal{C}$, a natural transformation $\eta : Id \Rightarrow T$ called the **unit**, and a natural transformation $\mu : T^2 \Rightarrow T$ called the **multiplication**, which satisfy the following axioms:



$$\mu \circ T\eta = Id_T \quad (\text{unit1})$$

$$\mu \circ \eta T = Id_T \quad (\text{unit2})$$

$$\mu \circ T\mu = \mu \circ \mu T \quad (\text{associativity})$$

We also give these axioms as commutative diagrams:

$$\begin{array}{ccc} & T & \\ T\eta \swarrow & \parallel & \searrow \eta T \\ TT & \xrightarrow{\mu} T & \xleftarrow{\mu} TT \end{array} \qquad \begin{array}{ccc} TTT & \xrightarrow{\mu T} & TT \\ T\mu \downarrow & & \downarrow \mu \\ TT & \xrightarrow{\mu} & T \end{array}$$

In string diagrams, the unit is denoted by  and the multiplication by . The axioms they satisfy are:

$$\begin{array}{c} \text{unit diagram} \\ \text{multiplication diagram} \end{array} = \begin{array}{c} \text{unit diagram} \\ \text{multiplication diagram} \end{array}, \quad \begin{array}{c} \text{multiplication diagram} \\ \text{multiplication diagram} \end{array} = \begin{array}{c} \text{multiplication diagram} \\ \text{multiplication diagram} \end{array}$$

We mostly restrict to monads on the category **Set** of sets and functions. In addition, if there is a finitary version and a full version of a monad, we mean the finitary one unless otherwise specified.

We list a few monads on **Set** that we will use throughout this thesis.

Example 2.2 (Exception Monad). For any set E , the **exception monad** $(- + E)$ is given by:

- $(X + E)$ is the disjoint union of X and E .
- η_X^E is the left inclusion morphism.
- μ_X^E is the identity on X , and collapses the two copies of each $e \in E$ down to a single copy. That is, $\mu : (X + E) + E \Rightarrow X + E$.

When E is a singleton set, this monad is also known as the **maybe monad**: $(-)_\perp$.

Example 2.3 (List Monad). The **list monad** L is given by:

- $L(X)$ is the set of all finite lists of elements of X .
- $\eta_X^L(x)$ is the singleton list $[x]$.
- μ_X^L concatenates a list of lists.

This monad is also known as the **free monoid monad**, in acknowledgement of its connection to the algebraic theory of monoids, see Section 2.4.3.

Example 2.4 (Multiset and Abelian Group Monad). The **multiset monad** M is given by:

- $M(X)$ is the set of all finite multisets¹ of elements of X .
- $\eta_X^M(x)$ is the singleton multiset $\{x\}$.
- μ_X^M takes a union of multisets, adding multiplicities.

We can generalise the notion of multiset to take multiplicities in the integers rather than the natural numbers. This results in the **Abelian group monad**. This monad is again named after its algebraic equivalent, see Section 2.4.3.

¹by which we mean: multisets in which only finitely many elements have a non-zero multiplicity. In other words: multisets with finite support. We assume the multiplicities are in the natural numbers. Multisets are also known as ‘bags’.

Example 2.5 (Powerset Monad). The **finite powerset monad** P is given by:

- $P(X)$ is the set of all finite subsets of X .
- $\eta_X^P(x)$ is the singleton set $\{x\}$.
- μ_X^P takes a union of sets.

Example 2.6 (Binary Tree Monad). The binary tree monad $Tree$ is given by:

- $Tree(X)$ is the set of all binary trees with leaves labelled by elements from X .
- $\eta_X^{Tree}(x)$ is the tree consisting of a single leaf labelled with x .
- μ_X^{Tree} flattens a tree of trees.

Example 2.7 (Distribution Monad). The **probability distribution monad** D is given by:

- $D(X)$ is the set of all finitely supported probability distributions over X .
- $\eta_X^D(x)$ is the point distribution at x .
- $\mu^D(e)(x)$ is the weighted average $\sum_{d \in \text{supp}(e)} e(d)d(x)$.

Example 2.8 (Reader Monad). For any set of states R , the **reader monad** $(-)^R$ is given by:

- X^R is the set of functions from R to X .
- $\eta_X^R(x)$ is constantly x .
- $\mu_X^R(f)(r) = f(r)(r)$.

Example 2.9 (Writer Monad). For any monoid $\langle W, *, 1 \rangle$, the **writer monad** $(-) \times W$ is given by:

- $X \times W$ is the Cartesian product of X and W .
- $\eta_X^W(x) = (x, 1)$.
- $\mu_X^W((x, w_1), w_2) = (x, w_1 * w_2)$.

2.2.2 Distributive Laws

To understand complex systems, it is often useful to view them as a combination of several simple systems. This idea of compositionality is found everywhere: computers are built from very simple logic gates and circuits, cities are built from houses, molecules are built from atoms. Since monads model computational behaviour, we would like to take several monads that each model a simple part, and combine them to model more complex phenomena.

There are several ways to combine monads, for instance by taking their (co)product [28] or their composition. We will consider the second option of these: combining monads by composing them. Since functors of the right type always compose, one expects monads to compose as well. Unfortunately, it turns out that composing monads is not as straightforward as composing functors.

The difficulty in composing monads is caused by the multiplication. For monads $\langle S, \eta^S, \mu^S \rangle$ and $\langle T, \eta^T, \mu^T \rangle$ to compose, we need a multiplication of type

$$TSTS \Rightarrow TS.$$

Simply composing the multiplications of two monads gives a natural transformation of type

$$\mu^T S \circ TT\mu^S : TTSS \Rightarrow TS.$$

This mismatch of types can be solved by pre-composing with a natural transformation λ of type $ST \Rightarrow TS$. Then:

$$T\lambda S : TSTS \Rightarrow TTSS,$$

and so we get a natural transformation of the right type:

$$\mu^T S \circ TT\mu^S \circ T\lambda S : TSTS \Rightarrow TS.$$

This is the core idea behind *distributive laws*.

Beck showed in 1969 that monads $\langle S, \eta^S, \mu^S \rangle$ and $\langle T, \eta^T, \mu^T \rangle$ can be composed if there is a distributive law between them [5]. A distributive law is a natural transformation λ of type $\lambda : ST \Rightarrow TS$, which satisfies some axioms defined below. The composition of two monads $\langle S, \eta^S, \mu^S \rangle$ and $\langle T, \eta^T, \mu^T \rangle$ is then defined as:

$$\langle T \circ S, \eta^T \eta^S, \mu^T \mu^S \circ T\lambda S \rangle.$$

Definition 2.10 (Distributive laws). Given two monads $\langle S, \eta^S, \mu^S \rangle$ and $\langle T, \eta^T, \mu^T \rangle$, a distributive law is a natural transformation $\lambda : ST \Rightarrow TS$ such that:

$$\lambda \circ \eta^S T = T \eta^S \quad (\text{unit1})$$

$$\lambda \circ S \eta^T = \eta^T S \quad (\text{unit2})$$

$$\lambda \circ \mu^S T = T \mu^S \circ \lambda S \circ S \lambda \quad (\text{multiplication1})$$

$$\lambda \circ S \mu^T = \mu^T S \circ T \lambda \circ \lambda T. \quad (\text{multiplication2})$$

These axioms can be visualised by the following commuting diagrams:

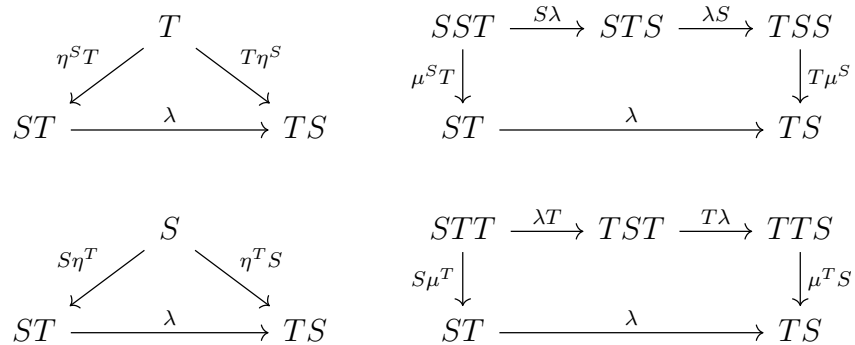

In string diagrammatic notation, the unit axioms are:

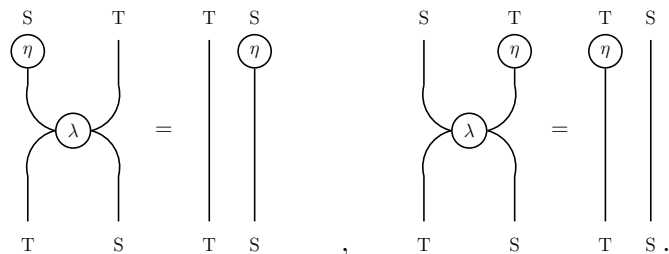

And the multiplication axioms are:

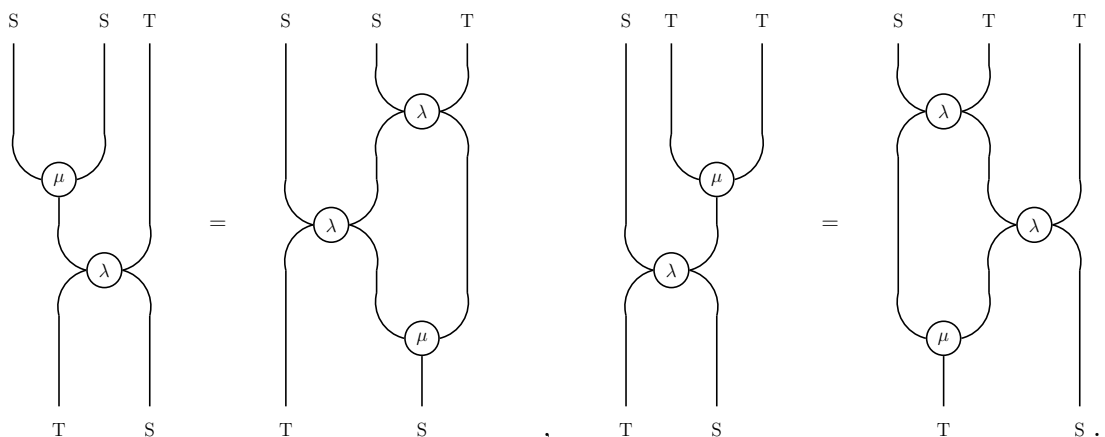

Remark 2.11. The string diagrams illustrate that in each of these equations, the unit or multiplication in the diagram on the left hand side is being ‘pulled through’ the distributive law to get the diagram on the right hand side. This intuitive way of representing distributive laws is further explored in *Dragging Proofs Out of Pictures* by Hinze and Marsden [26].

Remark 2.12. For a pair of monads S, T the expression ‘ S distributes over T ’ is often used. This phrasing is somewhat ambiguous: it could mean the underlying natural transformation has type $TS \Rightarrow ST$ or of type $ST \Rightarrow TS$, and conventions are applied inconsistently in the literature. We will therefore avoid this phrasing, and explicitly state the type of the natural transformation, for example ‘there is a distributive law of type $ST \Rightarrow TS$ ’.

Example 2.13 (Ring Monad). The most famous example of a distributive law involves the list monad and the Abelian group monad, and has type $LA \Rightarrow AL$ [5]. It captures exactly the distributivity of multiplication over addition. Writing a list as a formal product and a multiset with integer values as a formal sum, the distributive law can be written as:

$$\lambda \left(\prod_{i=0}^n \sum_{j_i=0}^{m_i} x_{ij_i} \right) = \sum_{j_0=0}^{m_0} \cdots \sum_{j_n=0}^{m_n} \prod_{i=0}^n x_{ij_i},$$

or more simply:

$$\lambda(a \cdot (b + c)) = (a \cdot b) + (a \cdot c). \tag{2.1}$$

The resulting composite monad is the ring monad. Note that a ring in algebra $(R, +, \times, 0, 1)$ consists of a monoid $(R, \times, 1)$ and an Abelian group $(R, +, 0)$. We explore this connection in more depth in Section 2.4.3.

In his paper, Beck remarks that he thinks it unlikely that a distributive law of type $AL \Rightarrow LA$ exists [5], that is, he believes that addition does not distribute over multiplication. In Chapter 5 we prove that Beck’s intuition is correct.

The term ‘distributive law’ is motivated by the ring monad example, and many other distributive laws are based on what we will call the ‘times over plus’ distributivity. An example is the distributive law for the multiset monad over itself:

Example 2.14 (Multiset Monad composed with itself). The multiset monad is well-known to distribute over itself. The action of the distributive law is exactly like the distribution of times over plus:

$$\lambda(\{\!\{a\}\!\}, \{\!\{b, c\}\!\}) = \{\!\{a, b\}\!\}, \{\!\{a, c\}\!\}.$$

More complicated multisets are distributed as if ‘multiplying out brackets’. For instance, applying the distributive law to $\wr(a, b, b) \cdot 2$ works exactly like multiplying out $(a + b + b) * (a + b + b)$:

$$\begin{aligned} \lambda(\wr(a, b, b) \cdot 2) &= \lambda(\wr(a, b, b), \wr(a, b, b)) \\ &= \wr(a, a), \wr(a, b), \wr(a, b), \\ &\quad \wr(b, a), \wr(b, b), \wr(b, b), \\ &\quad \wr(b, a), \wr(b, b), \wr(b, b) \\ &= \wr(a, a) \cdot 1, \wr(a, b) \cdot 4, \wr(b, b) \cdot 4. \end{aligned}$$

However, as we will see in Chapter 5, caution is needed: the validity of an equation such as (2.1) does not automatically imply the existence of a distributive law! Neither do all valid distributive laws resemble the distributivity of times over plus. Distributive laws need not even be unique. For example, Manes and Mulry have found three different distributive laws for the non-empty list monad over itself, none of which behave like times over plus:

Example 2.15 (Non-empty List Monad composed with itself). There are at least three distributive laws for the non-empty list monad over itself:

- [1] The first distributive law is given by a syntactic manipulation [44, Example 5.1.10]. It is best illustrated by an example. Given the list of lists $[[a], [b, c, d], [e, f]]$, every comma ‘,’ in between two elements is replaced by bracket-comma-bracket ‘], [’, and every occurrence of ‘], [’ in the list is replaced by a comma ‘,’:

$$\lambda([[a], [b, c, d], [e, f]]) = [[a, b], [c], [d, e], [f]].$$

- [2] The second distributive law for the non-empty list monad over itself [45, Example 4.10] is recursively defined as:

$$\begin{aligned} \lambda([[a_1, \dots, a_n]]) &= [[a_1], \dots, [a_n]], \\ \lambda(\mathcal{L}_1 \# \mathcal{L}_2) &= [\text{head}(\lambda(\mathcal{L}_1)) \# \text{head}(\lambda(\mathcal{L}_2))]. \end{aligned}$$

So for example:

$$\begin{aligned} \lambda([[a], [b, c], [d, e]]) &= [\text{head}(\lambda([a])) \# \text{head}(\lambda([b, c])) \# \text{head}(\lambda([d, e]))] \\ &= [\text{head}([a]) \# \text{head}([b], [c]) \# \text{head}([d], [e])] \\ &= [[a, b, d]]. \end{aligned}$$

More simply explained, this distributive law acts on a list of lists \mathcal{L} by taking the first element of each list L in \mathcal{L} . So $\lambda([[1], [2, 3, 4, 5, 6], [7, 8, 9]]) = [[1, 2, 7]]$. For functional programmers, in Haskell this distributive law can be written as: `wrap.map head`.

- [3] The third distributive law for the non-empty list monad over itself is similar to the second, but it consistently takes last element of a list instead of the first [45, Example 4.10].

2.2.3 Iterated Distributive Laws

Distribute laws aid in the composition of two monads. However, when composing three or more monads, distributive laws between each of them are no longer enough to coherently compose them. For monads T, S, R , the compositions $(TS)R$ and $T(SR)$ can be formed by finding a distributive law $R(TS) \Rightarrow (TS)R$ and $(SR)T \Rightarrow T(SR)$ respectively, after having found distributive laws to form the monads TS and SR . However, this by no means guarantees that the resulting monads $(TS)R$ and $T(SR)$ are the same. To guarantee associativity of composition, Cheng found that we need distributive laws $\lambda : ST \Rightarrow TS$, $\sigma : RT \Rightarrow TR$, and $\tau : RS \Rightarrow SR$, which additionally satisfy the Yang-Baxter equation [11]:

$$\lambda R \circ S \sigma \circ \tau T = T \tau \circ \sigma S \circ R \lambda.$$

That is, the following diagram commutes:

$$\begin{array}{ccccc}
 & & SRT & \xrightarrow{S\sigma} & STR & & \\
 & \nearrow^{\tau T} & & & & \searrow^{\lambda R} & \\
 RST & & & & & & TSR \\
 & \searrow_{R\lambda} & & & & & \\
 & & RTS & \xrightarrow{\sigma S} & TRS & & \\
 & & & & & \nearrow_{T\tau} &
 \end{array}$$

Written in string diagrams, this equation becomes:

Example 2.16. We can build the ring monad from Example 2.13 by composing three monads rather than two: the exception monad E with a single exception, the non-empty list monad L^+ and the Abelian group monad A . We know the following distributive laws:

$$\begin{aligned}\lambda &: L^+ A \Rightarrow AL^+ \\ \sigma &: EA \Rightarrow AE \\ \tau &: EL^+ \Rightarrow L^+ E,\end{aligned}$$

where λ is the distributive law from example Example 2.13, restricted to the non-empty list monad instead of the full list monad. σ and τ are the standard distributive laws for distributing the exception monad over any other monad, which maps exceptions to singleton exceptions and anything that is not an exception to itself.

The monad EL^+ is just the full list monad L , and so the monad $A(EL^+) = AL$ is the ring monad from Example 2.13. Since the distributive laws λ , σ , and τ satisfy Yang-Baxter, the monad $(AE)L^+$ also yields the ring monad. We leave it as an exercise to the reader to verify that these distributive laws indeed satisfy the Yang-Baxter equation.

Counterexample 2.17. In Example 2.14 we saw that the multiset monad distributes over itself to form the monad MM . To form the monad MMM , the distributive law for the multiset monad over itself would need to satisfy Yang-Baxter. Sadly, it does not. We found a counterexample using Haskell QuickCheck [13]. Consider the following element of MMM : $\{\emptyset, \{\emptyset\}\}$. For the distributive law to satisfy Yang-Baxter, the following equation must hold:

$$M\lambda \circ \lambda M \circ M\lambda \{\emptyset, \{\emptyset\}\} = \lambda M \circ M\lambda \circ \lambda M \{\emptyset, \{\emptyset\}\}.$$

However:

$$\begin{aligned}M\lambda \circ \lambda M \circ M\lambda \{\emptyset, \{\emptyset\}\} &= M\lambda \circ \lambda M \{\{\emptyset\}, \emptyset\} \\ &= M\lambda \emptyset \\ &= \emptyset,\end{aligned}$$

while:

$$\begin{aligned}\lambda M \circ M\lambda \circ \lambda M \{\emptyset, \{\emptyset\}\} &= \lambda M \circ M\lambda \emptyset \\ &= \lambda M \emptyset \\ &= \{\emptyset\}.\end{aligned}$$

The fact that this distributive law fails Yang-Baxter does not exclude the possibility of $(MM)M$ and $M(MM)$ to be monads via a distributive law. However, neither is true: in Theorem 5.4 we prove that there is no distributive law to form $(MM)M$, and in Theorem 5.10 we show that there is no distributive law to form the monad $M(MM)$.

2.3 Algebraic Theories

Monads and algebraic theories are two sides of the same coin. The intimate connection between them is well-known [38, 40, 42], and it forms the basis of most of the work presented in this thesis. In this section we recall the definition of an algebraic theory, after which, in the next section, we explain the connection between algebraic theories and monads.

Definition 2.18 (Algebraic Signature and Theory). An **algebraic signature** is a set Σ of operation symbols, each with an associated natural number referred to as its **arity**, denoted by a superscript (n) . That is, $+(^2)$ is an example of a binary operation symbol. The set of Σ -**terms** over a set X of variables is defined inductively as follows:

- Each element $x \in X$ is a term.
- If t_1, \dots, t_n are terms, and $\sigma \in \Sigma$ has arity n , then $\sigma(t_1, \dots, t_n)$ is a term.

An **algebraic theory** \mathbb{T} consists of:

- An algebraic signature $\Sigma^{\mathbb{T}}$.
- A set of pairs of Σ -terms over X , $E^{\mathbb{T}}$, referred to as the **equations** or **axioms** of \mathbb{T} . We will often write a pair $(s, t) \in E^{\mathbb{T}}$ as the more readable $s = t$ when convenient.

Two terms s and t are proven to be equal in the theory \mathbb{T} if their equality can be derived from the axioms of the theory using equational logic. Such a derivation is called a **proof in** \mathbb{T} . The inference rules of equational logic are summarised in Figure 2.1 below.

We will use the following terminology and notational conventions in this thesis:

- Operations of arity n will be referred to as **n -ary**. Operations of arity 1, 2 and 3 will be referred to as **unary, binary and ternary operations**. 0-ary terms will be referred to as **constants**.

Axiom:	$\frac{(s, t) \in E^{\mathbb{T}}}{s =_{\mathbb{T}} t}$
Reflexivity:	$\frac{}{t =_{\mathbb{T}} t}$
Symmetry:	$\frac{t =_{\mathbb{T}} t'}{t' =_{\mathbb{T}} t}$
Transitivity:	$\frac{t =_{\mathbb{T}} t' \quad t' =_{\mathbb{T}} t''}{t =_{\mathbb{T}} t''}$
Congruence:	
For any n -ary operation symbol σ :	$\frac{t_1 =_{\mathbb{T}} t'_1, \dots, t_n =_{\mathbb{T}} t'_n}{\sigma(t_1, \dots, t_n) =_{\mathbb{T}} \sigma(t'_1, \dots, t'_n)}$
Substitution:	
For any substitution f :	$\frac{t =_{\mathbb{T}} t'}{t[f] =_{\mathbb{T}} t'[f]}$

Figure 2.1: Inference rules of equational logic

- Variable contexts: If $Y \subseteq X$ is a set of variables and t is a term, then we write $Y \vdash t$ to mean that the free variables in t are a subset of Y . When we wish to make the algebraic theory of interest explicit, we will write $Y \vdash_{\mathbb{T}} t$ meaning t is a term of the algebraic theory \mathbb{T} in variable context Y .
- Set of free variables: If we need the precise set of free variables in a term t , we write $\text{var}(t)$. In addition, $\#\text{var}(t)$ denotes the cardinality of the set $\text{var}(t)$.
- Equality of terms: When two terms t_1, t_2 in \mathbb{T} can be proved equal using equational logic and axioms of \mathbb{T} as outlined in Figure 2.1, we write $t_1 =_{\mathbb{T}} t_2$. When we wish to be specific about which variables may appear in t_1 and t_2 , we will write:

$$X \vdash t_1 =_{\mathbb{T}} t_2 \quad \text{iff} \quad X \vdash t_1 \quad \text{and} \quad X \vdash t_2 \quad \text{and} \quad t_1 =_{\mathbb{T}} t_2.$$

- Substitution: For a term in context $Y \vdash_{\mathbb{T}} t$ and partial function f mapping variables in Y to \mathbb{T} -terms, we will write $t[f]$ or $t[f(y)/y]$ for the corresponding substitution of terms for variables where f is defined.

- Infix and postfix notation: We will extend our notation in the natural way to include infix notation for binary operation symbols with symbolic names, for example $a + b$, and postfix notation when it is standard to do so, for example to indicate a multiplicative inverse a^{-1} .

We give a few examples of common algebraic theories that will be of particular interest to us.

Example 2.19 (Inconsistent Theory). An inconsistent theory is an algebraic theory in which every term is equal to every other term, so it has only one equivalence class of terms. If any theory allows the derivation of $x = y$, then by substitution we know that the theory is inconsistent. We will use this frequently in our proofs, to show that the only possible composition of two theories is an inconsistent one, which is in general undesirable.

Example 2.20 (Pointed Sets). The algebraic theory of pointed sets has a signature with one constant, and no equations.

Example 2.21 (Monoids). The algebraic theory of monoids has a signature containing one constant e and one binary operation $*$, satisfying the axioms:

$$\begin{aligned} e * a &= a && \text{(left unit)} \\ a * e &= a && \text{(right unit)} \\ (a * b) * c &= a * (b * c). && \text{(associativity)} \end{aligned}$$

The theory of *commutative monoids* extends this theory with one further equation:

$$a * b = b * a. \quad \text{(commutativity)}$$

The theory of *join-semilattices* extends the theory of commutative monoids with the additional axiom:

$$a * a = a. \quad \text{(idempotence)}$$

These theories are part of a hierarchy of theories called the Boom hierarchy, which will be investigated in detail in Chapter 6.

Example 2.22 (Abelian Groups). The algebraic theory of Abelian groups has an additional operation beyond the signature of monoids. Its signature contains a constant e , a unary operation $(\cdot)^{-1}$ and binary operation $*$. The axioms are: left and right unit, associativity, commutativity, and:

$$\begin{aligned} a^{-1} * a &= e && \text{(left inverse)} \\ a * a^{-1} &= e. && \text{(right inverse)} \end{aligned}$$

In contexts where we are working with both monoids and Abelian groups, we will use the symbols $1, *$ for the constant and binary in monoids, and the symbols $0, -(\cdot), +$ for the constant, unary and binary in Abelian groups respectively.

2.4 Algebras and Algebras

Monads and algebraic theories are connected through their *algebras*. We first describe the algebras for an algebraic theory, then the algebras for a monad, and finally we explain the connection between them.

2.4.1 Algebras for an Algebraic Theory

Definition 2.23 (Σ -algebra). For a signature Σ , a Σ -**algebra** consists of:

- An underlying set A .
- For each n -ary operation $\sigma \in \Sigma^{\mathbb{T}}$ a function $\llbracket \sigma \rrbracket : A^n \rightarrow A$, called an **interpretation** of σ .

For a fixed Σ -algebra, every Σ -term $\{x_1, \dots, x_n\} \vdash t$ induces a function $\llbracket t \rrbracket : A^n \rightarrow A$, defined inductively as follows:

- For a variable $x_i \in A$, with $1 \leq i \leq n$:

$$\llbracket x_i \rrbracket(x_1, \dots, x_n) = x_i.$$

- For an m -ary operation $\sigma \in \Sigma$:

$$\llbracket \sigma(t_1, \dots, t_m) \rrbracket(x_1, \dots, x_n) = \llbracket \sigma \rrbracket(\llbracket t_1 \rrbracket(x_1, \dots, x_n), \dots, \llbracket t_m \rrbracket(x_1, \dots, x_n)).$$

A **homomorphism of Σ -algebras** of type $(A, \llbracket - \rrbracket^A) \rightarrow (B, \llbracket - \rrbracket^B)$ is a function $h : A \rightarrow B$ such that for each n -ary $\sigma \in \Sigma$:

$$h(\llbracket \sigma \rrbracket^A(x_1, \dots, x_n)) = \llbracket \sigma \rrbracket^B(h(x_1), \dots, h(x_n)).$$

Definition 2.24 ((Σ, E) -algebra). An **algebra for an algebraic theory** (Σ, E) is a Σ -algebra that satisfies all the equations in E . A Σ -algebra **satisfies the equation** $s =_{\mathbb{T}} t$ if:

$$\llbracket s \rrbracket = \llbracket t \rrbracket.$$

A (Σ, E) -**algebra homomorphism** is a Σ -algebra homomorphism between (Σ, E) -algebras. (Σ, E) -algebras and their homomorphisms form a category (Σ, E) -**Alg**.

Example 2.25 (Monoids on the Natural Numbers). The natural numbers with either addition and 0, or multiplication and 1, are algebras for the theory of monoids. That is, the following two form (Σ, E) -algebras for the theory of monoids:

$$\begin{array}{ll} \mathbb{N} & \mathbb{N} \\ \llbracket e \rrbracket = 0 & \llbracket e \rrbracket = 1 \\ \llbracket * \rrbracket = + & \llbracket * \rrbracket = \times \end{array}$$

Remark 2.26. It is not uncommon to have two algebraic theories that give rise to isomorphic categories of algebras. For instance, consider the following algebraic theory, having a signature with exactly one n -ary operation ϕ_n for each $n \in \mathbb{N}$, and flattening equations saying:

$$\phi_n(\phi_{m_1}(x_1^1, \dots, x_{m_1}^1), \dots, \phi_{m_n}(x_1^n, \dots, x_{m_n}^n)) = \phi_{\sum_i m_i}(x_1^1, \dots, x_{m_n}^n).$$

The category of algebras for this theory is isomorphic to the category of algebras for the theory of monoids.

Given a set A , there is a canonical way to construct a (Σ, E) -algebra on it.

Theorem 2.27. *For an algebraic theory \mathbb{T} , there is a left adjoint $F^{\mathbb{T}}$ to the obvious forgetful functor $U^{\mathbb{T}} : (\Sigma^{\mathbb{T}}, E^{\mathbb{T}})\text{-Alg} \rightarrow \mathbf{Set}$. The functor $F^{\mathbb{T}}$ is defined as follows:*

- For set A , $F^{\mathbb{T}}(A)$ is the set of equivalence classes of $\Sigma^{\mathbb{T}}$ -terms under provable equality in equational logic, as described in Figure 2.1.
- The action on a function $h : A \rightarrow B$ is defined inductively on representatives as follows:

$$\begin{aligned} F^{\mathbb{T}}(h)(a) &= h(a) \quad \text{for } a \in A, \\ F^{\mathbb{T}}(h)(\sigma(t_1, \dots, t_n)) &= \sigma(F^{\mathbb{T}}(h)(t_1), \dots, F^{\mathbb{T}}(h)(t_n)) \quad \text{for } n\text{-ary } \sigma \in \Sigma^{\mathbb{T}}. \end{aligned}$$

2.4.2 Algebras for a Monad

Monads also have a notion of algebra, which is defined as follows:

Definition 2.28 (Algebras for a Monad). Given a monad $\langle T, \eta, \mu \rangle$ on category \mathcal{C} , a T -algebra is a pair (X, h) , with X an object in \mathcal{C} and h a morphism of type $TX \rightarrow X$, such that the following equations hold:

$$\begin{aligned} h \circ \eta_X &= 1_X \\ h \circ Th &= h \circ \mu_X. \end{aligned}$$

These equations are visualised by the following commuting diagrams:

$$\begin{array}{ccc}
X & \xrightarrow{\eta_X} & TX \\
& \searrow & \downarrow h \\
& & X
\end{array}
\qquad
\begin{array}{ccc}
TTX & \xrightarrow{Th} & TX \\
\mu_X \downarrow & & \downarrow h \\
TX & \xrightarrow{h} & X
\end{array}$$

A **morphism** of T -algebras $(X, h_1) \rightarrow (Y, h_2)$ is a morphism $f : X \rightarrow Y$ such that:

$$h_2 \circ Tf = f \circ h_1,$$

or:

$$\begin{array}{ccc}
TX & \xrightarrow{Tf} & TY \\
h_1 \downarrow & & \downarrow h_2 \\
X & \xrightarrow{f} & Y
\end{array}$$

T -algebras and their morphisms form a category, called the **Eilenberg-Moore** (EM) category, usually denoted as \mathcal{C}^T , $\text{EM}(T)$, or $\text{Alg}(T)$. A T -algebra is also called an EM-algebra of T .

Example 2.29. A trivial example of a T -algebra is the pair (TX, μ_X) . This is called the free algebra on X . The category of all free algebras is called the **Kleisli** category, written as \mathcal{C}_T or $\text{Kl}(T)$.

Given an Eilenberg-Moore category \mathcal{C}^T , we can recover the monad T via the free-forgetful adjunction:

$$\mathcal{C} \begin{array}{c} \xrightarrow{F} \\ \xleftarrow{U} \end{array} \mathcal{C}^T,$$

where $T = U \circ F$.

2.4.3 Algebras *are* Algebras

We now have all the ingredients to describe monads algebraically. The key observation is that every category $(\Sigma^{\mathbb{T}}, E^{\mathbb{T}})\text{-Alg}$ is the Eilenberg-Moore category of some monad.

Definition 2.30 (Free Model Monad). For an algebraic theory $\mathbb{T} = (\Sigma^{\mathbb{T}}, E^{\mathbb{T}})$, the **free model monad** induced by \mathbb{T} is the monad induced by the free/forgetful adjunction $U^{\mathbb{T}} \circ F^{\mathbb{T}} : \mathbf{Set} \rightarrow (\Sigma^{\mathbb{T}}, E^{\mathbb{T}})\text{-Alg} \rightarrow \mathbf{Set}$.

It is well known that every finitary monad on the category of sets arises as a free model monad for some algebraic theory. In fact, every monad arises from a generalisation of algebraic theories, if we allow infinite arities [40, 42]. All the monads appearing in the present work are finitary, so we remain in the realm of conventional universal algebra.

Definition 2.31. We will say that **monad T has presentation/is presented by theory \mathbb{T}** or that **monad T and theory \mathbb{T} correspond to each other** if T is a free model monad induced by \mathbb{T} . In general, a monad has more than one presentation. Even so, if a certain presentation is commonly used for a monad, we refer to it as *the* theory presenting the monad.

Example 2.32. Many of the monads we have seen so far correspond to familiar algebraic theories. Some monads are even named in acknowledgment of this correspondence.

- [1] The maybe monad of Example 2.2 corresponds to the theory of pointed sets described in Example 2.20.
- [2] The list, multiset and finite powerset monads of Examples 2.3, 2.4 and 2.5 correspond respectively to the theories of monoids, commutative monoids and join-semilattices described in Example 2.21.
- [3] The Abelian group monad of Example 2.4 corresponds to the theory of Abelian groups described in Example 2.22.
- [4] The ring monad, which was constructed using a distributive law in Example 2.13, corresponds to the theory of rings.

Some monads have presentations that are less familiar:

- [5] The algebraic theory corresponding to the exception monad of Example 2.2 has a signature containing a constant for each exception, and no axioms.
- [6] The algebraic theory presenting the binary tree monad of Example 2.6 has a signature containing a constant and a binary operator. The axioms include the left and right unitality equations, but nothing else.
- [7] The algebraic theory corresponding to the distribution monad of Example 2.7 is the theory of convex, or barycentric, algebras [30,58]. These can be described as follows. For each $p \in (0, 1)$, the signature contains a binary operation $+^p$, and these satisfy the following axioms:

$$\begin{aligned}
 x +^p x &= x \\
 x +^p y &= y +^{1-p} x \\
 x +^p (y +^r z) &= (x +^{\frac{p}{p+(1-p)r}} y) +^{p+(1-p)r} z.
 \end{aligned}$$

Note that convex algebras are often described using binary operations for p in the closed interval $[0, 1]$, with an extra axiom stating that $x +^1 y = x$. The less redundant theory above is equivalent.

- [8] The algebraic theory corresponding to the reader monad has a signature containing just an n -ary operation, where n is the cardinality of the set of states R used in the reader monad. For the case $n = 2$ we introduce a binary operation $*$, with the intuitive reading of $x * y$ being “if the state is 1 do x else do y ”, the extension to larger state spaces has an analogous formulation describing how to proceed conditional on the state that is read. The axioms in the binary case are:

$$\begin{aligned}a * a &= a \\(a * b) * (c * d) &= a * d.\end{aligned}$$

The first axiom is idempotence and generalises easily to the general case. The second axiom generalises to taking a diagonal. The algebraic formulation of computational monads such as this one is described in *Notions of computation determine monads* by Plotkin and Power [53].

Chapter 3

Composite Theories

In this chapter we study composite theories and their relation to distributive laws for monads. A composite theory is an algebraic theory that is the result of ‘composing’ two other algebraic theories. In *Distributive laws for Lawvere theories*, Cheng has made this notion precise for Lawvere theories [12]. Piróg and Staton further developed Cheng’s ideas, formulating a concrete definition for universal algebra [52].

Intuitively, a composition of algebraic theories \mathbb{T} and \mathbb{S} should consist of exactly all the equivalence classes of \mathbb{T} -terms, using the equivalence classes of \mathbb{S} -terms as their variables. A naive way to try to achieve this would be to define:

$$\begin{aligned}\Sigma^{\mathbb{T}\circ\mathbb{S}} &= \Sigma^{\mathbb{T}} \uplus \Sigma^{\mathbb{S}} \\ E^{\mathbb{T}\circ\mathbb{S}} &= E^{\mathbb{T}} \cup E^{\mathbb{S}}.\end{aligned}$$

Unfortunately this is too simple, as the following example illustrates:

Non-Example 3.1. Consider the following theories, both consisting of a single binary operator and no equations:

$$\begin{array}{ll}\Sigma^{\mathbb{S}} = \{*(^{(2)})\} & \Sigma^{\mathbb{T}} = \{+(^{(2)})\} \\ E^{\mathbb{S}} = \emptyset & E^{\mathbb{T}} = \emptyset\end{array}$$

The naive attempt to form a composite theory gives:

$$\begin{aligned}\Sigma^{\mathbb{T}\circ\mathbb{S}} &= \{*(^{(2)}), +(^{(2)})\} \\ E^{\mathbb{T}\circ\mathbb{S}} &= \emptyset.\end{aligned}$$

We would like our composite theory to consist of terms made of $+$, using terms made of $*$ as variables. So a typical term would be $(a*b)+(c*d)$, but not $(a+b)*c$. The naive theory $\Sigma^{\mathbb{T}\circ\mathbb{S}}, E^{\mathbb{T}\circ\mathbb{S}}$ unfortunately has both of these terms. Since there are no equations

in this theory, every term is its own equivalence class, and terms ‘in the wrong order’ like $(a + b) * c$ form unwanted equivalence classes in our naive composition. In fact, the theory $\Sigma^{\mathbb{T} \circ \mathbb{S}}, E^{\mathbb{T} \circ \mathbb{S}}$ forms the *sum* of the two theories, rather than a composition.

Defining a theory in which these unwanted terms are absent is impossible: any theory that has the terms $a + b$ and $d * c$ will by definition have the term $(a + b) * c$ as well. A solution is to introduce more equations, ensuring that every term ‘in the wrong order’, that is, with \mathbb{T} -terms inside \mathbb{S} -terms, is equal to a term ‘in the right order’: a single \mathbb{T} -term, with \mathbb{S} -terms as variables. Of course equating everything achieves this goal, but not in a useful way. Piróg and Staton’s definition of a composite theory strikes the perfect balance between adding enough equations to make every term equal to a term ‘in the right order’, while still preserving the properties of the individual theories. The following definition is a slight rephrasing of the original.

Definition 3.2 (Composite Theories [52]). Let \mathbb{U} be an algebraic theory that contains two theories \mathbb{S} and \mathbb{T} , that is, \mathbb{U} has all the functions, constants and equations of both \mathbb{S} and \mathbb{T} .

- A term in \mathbb{U} is **separated** if it is of the form $t [s_x/x]$, where $X \vdash_{\mathbb{T}} t$ and s_x is a family of \mathbb{S} -terms indexed by $x \in X$.
- If there are terms $X \vdash_{\mathbb{T}} t$ and $Y \vdash_{\mathbb{T}} t'$, and families of \mathbb{S} -terms $\{s_x \mid x \in X\}$ and $\{s'_y \mid y \in Y\}$, we say that $t [s_x/x]$ and $t' [s'_y/y]$ are **equal modulo** (\mathbb{S}, \mathbb{T}) if there are functions $h : X \rightarrow Z$, $h' : Y \rightarrow Z$ and terms $\{\bar{s}_z \mid z \in Z\}$, such that:

$$(a) \quad t [h(x)/x] =_{\mathbb{T}} t' [h'(y)/y].$$

$$(b) \quad \forall x \in X : s_x =_{\mathbb{S}} \bar{s}_{h(x)}.$$

$$(c) \quad \forall y \in Y : s'_y =_{\mathbb{S}} \bar{s}_{h'(y)}.$$

The theory \mathbb{U} is said to be a **composite of \mathbb{T} after \mathbb{S}** if every term u in \mathbb{U} is equal to a separated term, and moreover this term is **essentially unique** in the sense that if any two terms v, v' are separated and $v =_{\mathbb{U}} v'$ then v and v' are equal modulo (\mathbb{S}, \mathbb{T}) .

Remark 3.3. Note that composite theories are oriented: a composite of \mathbb{S} after \mathbb{T} is not equivalent to a composite of \mathbb{T} after \mathbb{S} , since it matters which terms are used as variables for the other.

Also notice that a composite of two theories is not necessarily unique. Given two algebraic theories \mathbb{S} and \mathbb{T} , we therefore speak of *a composite theory* \mathbb{U} , not of *the composite theory* $\mathbb{T} \circ \mathbb{S}$. Composite theories correspond one-to-one to distributive laws between monads [52]. In Section 3.1 we prove this connection constructively.

Before proving the connection between distributive laws and composite theories, we introduce a few equivalent formulations of equality modulo (\mathbb{S}, \mathbb{T}) , which will be useful throughout this thesis. The third formulation will be particularly useful in our proofs, because it allows us to use the implications in both directions.

Proposition 3.4. *Let \mathbb{S} and \mathbb{T} be two algebraic theories, and let \mathbb{U} be an algebraic theory that contains both \mathbb{S} and \mathbb{T} . For terms $X \vdash_{\mathbb{T}} t$, $Y \vdash_{\mathbb{T}} t'$ and families of \mathbb{S} -terms $\{s_x \mid x \in X\}$, $\{s'_y \mid y \in Y\}$, the following are equivalent:*

1. *The terms $t[s_x/x]$ and $t'[s'_y/y]$ are equal modulo (\mathbb{S}, \mathbb{T}) . That is: there are functions $h : X \rightarrow Z$, $h' : Y \rightarrow Z$ and terms $\{\bar{s}_z \mid z \in Z\}$, such that:*

- (a) $t[h(x)/x] =_{\mathbb{T}} t'[h'(y)/y]$.
- (b) $\forall x \in X : s_x =_{\mathbb{S}} \bar{s}_{h(x)}$.
- (c) $\forall y \in Y : s'_y =_{\mathbb{S}} \bar{s}_{h'(y)}$.

2. *There are functions $h : X \rightarrow Z$, $h' : Y \rightarrow Z$ satisfying:*

- (a) $t[h(x)/x] =_{\mathbb{T}} t'[h'(y)/y]$.
- (b) $\forall x_1, x_2 \in X : h(x_1) = h(x_2) \Rightarrow s_{x_1} =_{\mathbb{S}} s_{x_2}$.
- (c) $\forall y_1, y_2 \in Y : h'(y_1) = h'(y_2) \Rightarrow s'_{y_1} =_{\mathbb{S}} s'_{y_2}$.
- (d) $\forall x \in X, y \in Y : h(x) = h'(y) \Rightarrow s_x =_{\mathbb{S}} s'_y$.

3. *There are functions $f : X \rightarrow Z$, $f' : Y \rightarrow Z$ satisfying:*

- (a) $t[f(x)/x] =_{\mathbb{T}} t'[f'(y)/y]$.
- (b) $\forall x_1, x_2 \in X : f(x_1) = f(x_2) \Leftrightarrow s_{x_1} =_{\mathbb{S}} s_{x_2}$.
- (c) $\forall y_1, y_2 \in Y : f'(y_1) = f'(y_2) \Leftrightarrow s'_{y_1} =_{\mathbb{S}} s'_{y_2}$.
- (d) $\forall x \in X, y \in Y : f(x) = f'(y) \Leftrightarrow s_x =_{\mathbb{S}} s'_y$.

4. *There are:*

- *Substitutions $f : X \rightarrow Z$, $f' : Y \rightarrow Z$,*
- *A substitution $g : Z \rightarrow \mathbb{S}$,*
- *A proof P in \mathbb{T} proving $t[f][g] =_{\mathbb{T}} t'[f'][g]$,*
- *For each $x \in X$ and $y \in Y$, proofs P_x and P'_y in \mathbb{S} proving $s_x =_{\mathbb{S}} g \circ f(x)$ and $s'_y =_{\mathbb{S}} g \circ f'(y)$,*

such that the following is a proof of $t[s_x/x] =_{\cup} t'[s'_y/y]$:

$$\frac{\frac{\frac{[P_x] \quad s_x = g \circ f(x)}{t[s_x/x] = t[f][g]} \text{ [gen]}}{t[s_x/x] = t'[f'][g]} \text{ [trans]}}{\frac{\frac{[P] \quad t[f] = t'[f']}{t[f][g] = t'[f'][g]} \text{ [sub]}}{t[s_x/x] = t'[f'][g]} \text{ [trans]}} \quad \frac{\frac{\frac{[P'_y] \quad s'_y = g \circ f'(y)}{t'[s'_y/y] = t'[f'][g]} \text{ [gen]}}{t'[f'][g] = t'[s'_y/y]} \text{ [sym]}}{t[s_x/x] = t'[s'_y/y]} \text{ [trans]}$$

Proof.

1 \Rightarrow 2: By transitivity of $=_{\mathbb{S}}$.

2 \Rightarrow 1: Taking Z' to be the union of the ranges of h and h' , requirements 2b-2d ensure that we can choose $\bar{s}_{z'}$ such that:

$$\bar{s}_{z'} = \begin{cases} s_x, & \text{if } h(x) = z' \\ s_y, & \text{if } h'(y) = z'. \end{cases}$$

2 \Rightarrow 3: We need to show that the reverse implications of properties 2a-2d hold. To this end, we pick a function $g : Z \rightarrow Z'$ such that:

- If $s_{x_1} =_{\mathbb{S}} s_{x_2}$, then $g(h(x_1)) = g(h(x_2))$.
- If $s'_{y_1} =_{\mathbb{S}} s'_{y_2}$, then $g(h'(y_1)) = g(h'(y_2))$.
- If $s_x =_{\mathbb{S}} s'_y$, then $g(h(x)) = g(h'(y))$.

The function g effectively takes a quotient of Z , defined by the three conditions above. Transitivity of equality ensures that the compositions $f = g \circ h$ and $f' = g \circ h'$ preserve properties 2a-2d. By definition, they also satisfy the reverse implications, and so they satisfy condition 3.

3 \Rightarrow 2: Trivial.

1 \Rightarrow 4: Given h and h' , we take these as the substitutions f, f' . We define the substitution g as $g(z) = \bar{s}_z$. Then property 1a ensures the existence of proof P , while properties 1b and 1c ensure the existence of proofs P_x and P'_y to complete the proof tree.

4 \Rightarrow 1: We take f and f' given by 4 as the functions h and h' asked for by 1. We set $\bar{s}_{h(x)} = g \circ f(x)$ and $\bar{s}_{h'(y)} = g \circ f'(y)$. Then the proof P witnesses property 1a and the proofs P_x and P'_y witness properties 1b and 1c respectively. \square

A property of composite theories worth mentioning is that they are never inconsistent (see Example 2.19), unless their component theories are inconsistent themselves.

Proposition 3.5. *If \mathbb{U} is a composite theory of theories \mathbb{T} after \mathbb{S} , and both \mathbb{S} and \mathbb{T} are consistent, then \mathbb{U} is consistent.*

Proof. Suppose for contradiction that \mathbb{U} is an inconsistent theory. Then for each pair of variables x, y we have $x =_{\mathbb{U}} y$. Since both x and y are separated terms, essential uniqueness gives us two substitutions $f : \{x\} \rightarrow Z$ and $g : \{y\} \rightarrow Z$ such that:

$$\begin{aligned} x[f] &=_{\mathbb{T}} y[g] \\ f(x) = g(y) &\Leftrightarrow x =_{\mathbb{S}} y. \end{aligned}$$

For the first equation to be satisfied without violating the consistency of \mathbb{T} , we must have that $f(x) = g(y)$. This implies, however, that $x =_{\mathbb{S}} y$, which contradicts the consistency of \mathbb{S} . We hence conclude that if \mathbb{U} is a composite theory of \mathbb{T} after \mathbb{S} , \mathbb{U} must be consistent. \square

3.1 The Constructive Connection

Composite theories are the algebraic equivalent of distributive laws between monads. That is, there is a one-to-one correspondence between composite theories \mathbb{U} of \mathbb{T} after \mathbb{S} and distributive laws λ of type $ST \Rightarrow TS$, where S and T are the free model monads of theories \mathbb{S} and \mathbb{T} respectively. This fact was already stated by Piróg and Staton [52], but they do not give the proof in their paper. Here, we present an explicit version of this proof, which allows us to construct a distributive law from a composite theory and vice versa. Similar observations have been made by Lack [37, Proposition 4.7], written up more explicitly by Zanasi in his thesis [63, Proposition 2.27]. Their results hold for symmetric monoidal theories.

Remark 3.6. The following proofs need substitutions $t[s_x/x]$, equivalence classes $[t]_{\mathbb{T}}$, and interpretations $[\sigma]$. All of these are traditionally denoted by square brackets. We trust that we have made them sufficiently distinct to avoid confusion. Still, the proofs are inherently fiddly, even though they are technically quite straightforward.

Theorem 3.7. *Let \mathbb{S} and \mathbb{T} be algebraic theories presenting monads S and T , and let \mathbb{U} be a composite theory of \mathbb{T} after \mathbb{S} . Then the free model monad U is isomorphic to the composition of $T \circ S$ via the distributive law mapping the equivalence class of representative $s[t_x/x]$ to the suitable equivalence class of a separated term in \mathbb{U} equal to $s[t_x/x]$.*

Proof. We first argue that the functor U is isomorphic to the functor TS by finding a natural isomorphism between them. We will use $[t]_{\mathbb{T}}$ to denote the equivalence class of term t in theory \mathbb{T} . Let $[u]_{\mathbb{U}}$ be any element of UX . Since \mathbb{U} is a composite theory, we know $[u]_{\mathbb{U}}$ has a representative that is separated, that is, of form $t[s_x/x]$ for some term t in \mathbb{T} and terms s_x in \mathbb{S} . We use this representative to define a natural transformation $\phi : U \Rightarrow TS$ as follows:

$$\phi [u]_{\mathbb{U}} = [t[[s_x]_{\mathbb{S}}/x]]_{\mathbb{T}}.$$

That is, ϕ maps the equivalence class of u to the equivalence class of term t in \mathbb{T} , with the equivalence classes of the terms s_x in theory \mathbb{S} as the variables in t . The essential uniqueness property of \mathbb{U} ensures that this is well-defined: if $t'[s'_y/y]$ is any other separated representative of $[u]_{\mathbb{U}}$, then by essential uniqueness we have:

$$[t[[s_x]_{\mathbb{S}}/x]]_{\mathbb{T}} = [t'[[s'_y]_{\mathbb{S}}/y]]_{\mathbb{T}}.$$

The natural transformation ϕ has inverse $\psi : TS \Rightarrow U$, given by:

$$\phi [t[[s_x]_{\mathbb{S}}/x]]_{\mathbb{T}} = [t[s_x/x]]_{\mathbb{U}}.$$

We conclude that the functor TS has a monad structure given by the monad structure of the free model monad U of theory \mathbb{U} . To prove that this monad structure comes from a distributive law, we use the following equivalent statement [5]:

- $\langle TS, \eta^T \eta^S, \mu^{TS} \rangle$ is a monad, with multiplication $\mu^{TS} = \phi \circ \mu^U \circ \psi TS \psi$.
- The natural transformations $\eta^T S$ and $T \eta^S$ are monad maps.
- The middle unitary law holds: $\mu^{TS} \circ T \eta^S \eta^T S = Id_{TS}$.

The distributive law is then given by:

$$\lambda = \mu^{TS} \circ \eta^T S T \eta^S.$$

We have established that $\langle TS, \eta^T \eta^S, \mu^{TS} \rangle$ is indeed monad, isomorphic to the free model monad of the theory \mathbb{U} . For the next bullet we need to show that $\eta^T S$ and $T \eta^S$ are monad maps. That is:

- $\mu^{TS} \circ \eta^T S \circ \eta^T S = \eta^T S \circ \mu^S$.
- $\mu^{TS} \circ T \eta^S \circ T \eta^S = T \eta^S \circ \mu^T$.

We show the first of these. Given any $[s[[s_x]_{\mathbb{S}}/x]]_{\mathbb{S}}$ in SSX , we have:

$$\begin{aligned}\eta^T S \circ \mu^S [s[[s_x]_{\mathbb{S}}]]_{\mathbb{S}} &= \eta^T S [s[s_x/x]]_{\mathbb{S}} \\ &= [[s[s_x/x]]_{\mathbb{S}}]_{\mathbb{T}}.\end{aligned}$$

On the other hand:

$$\begin{aligned}\mu^{TS} \circ \eta^T S \circ \eta^T S [s[[s_x]_{\mathbb{S}}/x]]_{\mathbb{S}} &= \mu^{TS} [[s[[[s_x]_{\mathbb{S}}]_{\mathbb{T}}/x]]_{\mathbb{S}}]_{\mathbb{T}} \\ &= \phi \circ \mu^U \circ \psi T S \psi [[s[[[s_x]_{\mathbb{S}}]_{\mathbb{T}}/x]]_{\mathbb{S}}]_{\mathbb{T}} \\ &= \phi \circ \mu^U [s[[s_x]_{\mathbb{U}}/x]]_{\mathbb{U}} \\ &= \phi [s[s_x/x]]_{\mathbb{U}} \\ &= [[s[s_x/x]]_{\mathbb{S}}]_{\mathbb{T}},\end{aligned}$$

which proves that $\eta^T S$ is a monad map. The proof for $T\eta^S$ is similar.

Finally, we need to show the middle unitary law: $\mu^{TS} \circ T\eta^S \eta^T S = Id_{TS}$. Let $[t[[s_x]_{\mathbb{S}}/x]]_{\mathbb{T}}$ be any element of TSX . Then:

$$\begin{aligned}\mu^{TS} \circ T\eta^S \eta^T S [t[[s_x]_{\mathbb{S}}/x]]_{\mathbb{T}} &= \mu^{TS} [t[[[[s_x]_{\mathbb{S}}]_{\mathbb{T}}/x]]_{\mathbb{T}}]_{\mathbb{T}} \\ &= \phi \circ \mu^U \circ \psi T S \psi [t[[[[s_x]_{\mathbb{S}}]_{\mathbb{T}}/x]]_{\mathbb{T}}]_{\mathbb{T}} \\ &= \phi \circ \mu^U [t[[s_x]_{\mathbb{U}}/x]]_{\mathbb{U}} \\ &= \phi [t[s_x/x]]_{\mathbb{U}} \\ &= [t[[s_x]_{\mathbb{S}}/x]]_{\mathbb{T}} \\ &= Id_{TS} [t[[s_x]_{\mathbb{S}}/x]]_{\mathbb{T}}.\end{aligned}$$

So the monad $\langle TS, \eta^T \eta^S, \mu^{TS} \rangle$ does indeed come from a distributive law. We find the distributive law through:

$$\lambda = \mu^{TS} \circ \eta^T S T \eta^S.$$

Let $[s[[t_x]_{\mathbb{T}}/x]]_{\mathbb{S}}$ be any element of STX , then:

$$\begin{aligned}\lambda [s[[t_x]_{\mathbb{T}}/x]]_{\mathbb{S}} &= \mu^{TS} \circ \eta^T S T \eta^S [s[[t_x]_{\mathbb{T}}/x]]_{\mathbb{S}} \\ &= \mu^{TS} [[s[[[t_x]_{\mathbb{S}}]_{\mathbb{T}}/x]]_{\mathbb{S}}]_{\mathbb{T}} \\ &= \phi \circ \mu^U \circ \psi T S \psi [[s[[[t_x]_{\mathbb{S}}]_{\mathbb{T}}/x]]_{\mathbb{S}}]_{\mathbb{T}} \\ &= \phi \circ \mu^U [s[[t_x]_{\mathbb{U}}/x]]_{\mathbb{U}} \\ &= \phi [s[t_x/x]]_{\mathbb{U}}.\end{aligned}$$

Let $t'[s'_x/x]$ be a separated term such that $t'[s'_x/x] =_{\mathbb{U}} s[t_x/x]$. By the separation axiom of composite theories, such a term $t'[s'_x/x]$ exists. Then:

$$\begin{aligned}\phi [s[t_x/x]]_{\mathbb{U}} &= \phi [t'[s'_x/x]]_{\mathbb{U}} \\ &= [t'[[s'_x]_{\mathbb{S}}/x]]_{\mathbb{T}},\end{aligned}$$

which is what the theorem claims $\lambda [s[[t_x]_{\mathbb{T}}/x]]_{\mathbb{S}}$ to be. The essential uniqueness property of composite theories ensures that λ is well-defined. \square

To prove the other direction, we build a composite theory from a distributive law.

Definition 3.8 (Theory \mathbb{U}^λ). Let S and T be the free model monads of algebraic theories \mathbb{S} and \mathbb{T} . If there is a distributive law $\lambda : ST \Rightarrow TS$, then we define the set of λ -equations E^λ as follows: Let $s[t_x/x]$ be a representative of an element in STX , and $t[s_y/y]$ a representative of an element in TSX . Then $s[t_x/x] = t[s_y/y] \in E^\lambda$ iff λ maps the equivalence class of $s[t_x/x]$ to the equivalence class of $t[s_y/y]$.

We can then define the **algebraic theory** \mathbb{U}^λ as:

$$\begin{aligned}\Sigma^{\mathbb{U}^\lambda} &= \Sigma^{\mathbb{S}} \uplus \Sigma^{\mathbb{T}} \\ E^{\mathbb{U}^\lambda} &= E^{\mathbb{S}} \cup E^{\mathbb{T}} \cup E^\lambda.\end{aligned}$$

Theorem 3.9. *Let S and T be the free model monads of algebraic theories \mathbb{S} and \mathbb{T} . If there is a distributive law $\lambda : ST \Rightarrow TS$, then the theory \mathbb{U}^λ is a composite theory of \mathbb{T} after \mathbb{S} , and the monad $\langle TS, \eta^T \eta^S, \mu^T \mu^S \circ T\lambda S \rangle$ is the free model monad of this theory.*

Proof. From Piróg and Station [52, Theorem 5], we already know that λ induces a monad that is the free model monad of a composite of \mathbb{T} after \mathbb{S} . What is left to show is that \mathbb{U}^λ is a representation of this composite theory. We prove this by establishing an isomorphism between the Eilenberg-Moore category of the monad TS and the category of algebras for \mathbb{U}^λ .

Define the functor $F : \mathcal{C}^{TS} \rightarrow \mathbb{U}^\lambda\text{-Alg}$ as follows:

- F maps an algebra (A, a) in \mathcal{C}^{TS} to the algebra $(A, [[\cdot]]^a)$, where $[[\cdot]]^a$ is defined by:

$$\begin{aligned}[[\sigma]]^a(x_1, \dots, x_n) &= \begin{cases} a \circ \eta^T S [\sigma(x_1, \dots, x_n)]_{\mathbb{S}}, & \text{if } \sigma \in \Sigma^{\mathbb{S}} \\ a \circ T \eta^S [\sigma(x_1, \dots, x_n)]_{\mathbb{T}}, & \text{if } \sigma \in \Sigma^{\mathbb{T}} \end{cases} \\ &= \begin{cases} a [[\sigma(x_1, \dots, x_n)]_{\mathbb{S}}]_{\mathbb{T}}, & \text{if } \sigma \in \Sigma^{\mathbb{S}} \\ a [\sigma([x_1]_{\mathbb{S}}, \dots, [x_n]_{\mathbb{S}})]_{\mathbb{T}}, & \text{if } \sigma \in \Sigma^{\mathbb{T}}. \end{cases}\end{aligned}$$

- F maps a morphism $h : (A, a) \rightarrow (B, b)$, which is a function $A \rightarrow B$, to itself, now interpreted as a morphism $h : (A, \llbracket \cdot \rrbracket^a) \rightarrow (B, \llbracket \cdot \rrbracket^b)$.

The interpretation $\llbracket \cdot \rrbracket^a$ extends to any term $u \in \mathbb{U}$ in the standard inductive way:

- For a variable x :

$$\llbracket x \rrbracket^a = x.$$

- For any m -ary operation $\sigma \in \Sigma^{\mathbb{U}^\lambda}$ and terms u_1, \dots, u_m in \mathbb{U}^λ :

$$\llbracket \sigma(u_1, \dots, u_m) \rrbracket^a = \llbracket \sigma \rrbracket^a(\llbracket u_1 \rrbracket^a, \dots, \llbracket u_m \rrbracket^a).$$

We will show that the interpretation $\llbracket \cdot \rrbracket^a$ behaves as you would expect, namely for any term u in \mathbb{U}^λ and any separated term $t[s_x/x]$ such that $u =_{\mathbb{U}^\lambda} t[s_x/x]$:

$$\llbracket u \rrbracket^a = a[t[\llbracket s_x \rrbracket_{\mathbb{S}}/x]]_{\mathbb{T}}. \quad (3.1)$$

That is, the interpretation of u according to a is the result of applying a to the equivalence class of the term t , with equivalence classes of the terms s_x as variables.

Notice that the essential uniqueness property ensures that Equation(3.1) is well-defined for equivalence classes: for any two separated terms $t[s_x/x] =_{\mathbb{U}^\lambda} u =_{\mathbb{U}^\lambda} t'[s'_x/x']$ we have by essential uniqueness that $[t[\llbracket s_x \rrbracket_{\mathbb{S}}/x]]_{\mathbb{T}} = [t'[\llbracket s'_x \rrbracket_{\mathbb{S}}/x']]_{\mathbb{T}}$.

The proof of Equation(3.1) is by induction. If u is a variable, the claim is trivial. Now suppose that the claim holds for terms u_1, \dots, u_m and let σ be an m -ary operation in $\Sigma^{\mathbb{U}^\lambda}$. Then either $\sigma \in \Sigma^{\mathbb{S}}$ or $\sigma \in \Sigma^{\mathbb{T}}$. We prove these two cases separately.

- $\sigma \in \Sigma^{\mathbb{S}}$. Then:

$$\begin{aligned} & \llbracket \sigma(u_1, \dots, u_m) \rrbracket^a \\ &= \{ \text{inductive definition of interpretations} \} \\ & \llbracket \sigma \rrbracket^a(\llbracket u_1 \rrbracket^a, \dots, \llbracket u_m \rrbracket^a) \\ &= \{ \text{definition of } \llbracket \sigma \rrbracket^a \text{ for } \sigma \in \Sigma^{\mathbb{S}} \} \\ & a[\llbracket \sigma(\llbracket u_1 \rrbracket^a, \dots, \llbracket u_m \rrbracket^a) \rrbracket_{\mathbb{S}}]_{\mathbb{T}} \\ &= \{ \text{IH, where } t_i[s_x/x] \text{ is a separated term equal to } u_i \} \\ & a[\llbracket \sigma(a[t_1[\llbracket s_x \rrbracket_{\mathbb{S}}/x]]_{\mathbb{T}}, \dots, a[t_m[\llbracket s_x \rrbracket_{\mathbb{S}}/x]]_{\mathbb{T}}) \rrbracket_{\mathbb{S}}]_{\mathbb{T}} \\ &= \{ \text{moving the application of } a \text{ to the front} \} \\ & a \circ T S a[\llbracket \sigma([t_1[\llbracket s_x \rrbracket_{\mathbb{S}}/x]]_{\mathbb{T}}, \dots, [t_m[\llbracket s_x \rrbracket_{\mathbb{S}}/x]]_{\mathbb{T}}) \rrbracket_{\mathbb{S}}]_{\mathbb{T}} \\ &= \{ a \circ T S a = a \circ \mu^{TS} \} \\ & a \circ \mu^{TS}[\llbracket \sigma([t_1[\llbracket s_x \rrbracket_{\mathbb{S}}/x]]_{\mathbb{T}}, \dots, [t_m[\llbracket s_x \rrbracket_{\mathbb{S}}/x]]_{\mathbb{T}}) \rrbracket_{\mathbb{S}}]_{\mathbb{T}} \end{aligned}$$

$$\begin{aligned}
&= \{ \mu^{TS} = \mu^T \mu^S \circ T\lambda S \} \\
&\quad a \circ \mu^T \mu^S \circ T\lambda S \llbracket \sigma([t_1 \llbracket [s_x]_{\mathbb{S}}/x \rrbracket]_{\mathbb{T}}, \dots, [t_m \llbracket [s_x]_{\mathbb{S}}/x \rrbracket]_{\mathbb{T}}) \rrbracket_{\mathbb{S}} \rrbracket_{\mathbb{T}}. \quad (3.2)
\end{aligned}$$

We know that λ maps equivalence classes of form $[s \llbracket [t_x]_{\mathbb{T}}/x \rrbracket]_{\mathbb{S}}$ to equivalence classes of form $[t \llbracket [s_y]_{\mathbb{S}}/y \rrbracket]_{\mathbb{T}}$. So suppose that

$$\lambda [\sigma([t_1]_{\mathbb{T}}, \dots, [t_m]_{\mathbb{T}})]_{\mathbb{S}} = [t' \llbracket [s'_y]_{\mathbb{S}}/y \rrbracket]_{\mathbb{T}}$$

for some term $t' [s'_y/y]$. We continue our reasoning from (3.2):

$$\begin{aligned}
(3.2) &= \{ \text{if } \lambda [\sigma([t_1]_{\mathbb{T}}, \dots, [t_m]_{\mathbb{T}})]_{\mathbb{S}} = [t' \llbracket [s'_y]_{\mathbb{S}}/y \rrbracket]_{\mathbb{T}} \} \\
&\quad a \circ \mu^T \mu^S \llbracket [t' \llbracket [s'_y]_{\mathbb{S}}/y \rrbracket]_{\mathbb{T}} \llbracket [s_x]_{\mathbb{S}}/x \rrbracket]_{\mathbb{S}} \rrbracket_{\mathbb{T}} \\
&= \{ \text{applying the multiplications} \} \\
&\quad a [t' \llbracket [s'_y]_{\mathbb{S}} [s_x/x] \rrbracket]_{\mathbb{T}}.
\end{aligned}$$

To finish the proof for this case we need to show that $t' [s'_y [s_x/x]]$ is a separated term equal to $\sigma(u_1, \dots, u_m)$. By the induction hypothesis, we know that all u_i are equal to the separated terms $t_i [s_x/x]$ so we can write:

$$\sigma(u_1, \dots, u_m) = \sigma(t_1 [s_x/x], \dots, t_m [s_x/x]) = \sigma(t_1, \dots, t_m) [s_x/x].$$

By definition of \mathbb{U}^λ and the axiom of substitution, this term is indeed equal to a TS -representative of $\lambda [\sigma([t_1]_{\mathbb{T}}, \dots, [t_m]_{\mathbb{T}})]_{\mathbb{S}}$, followed by the substitution $x \mapsto s_x$. We assumed this TS -representative to be $t' [s'_y/y]$, and hence:

$$\sigma(t_1, \dots, t_m) [s_x/x] =_{\mathbb{U}^\lambda} t' [s'_y/y] [s_x/x] = t' [s'_y [s_x/x]],$$

which is what we needed to show.

- $\sigma \in \Sigma^T$. Then:

$$\begin{aligned}
&\llbracket \sigma(u_1, \dots, u_m) \rrbracket^a \\
&= \{ \text{inductive definition of interpretations} \} \\
&\quad \llbracket \sigma \rrbracket^a (\llbracket u_1 \rrbracket^a, \dots, \llbracket u_m \rrbracket^a) \\
&= \{ \text{definition of } \llbracket \sigma \rrbracket^a \text{ for } \sigma \in \Sigma^{\mathbb{T}} \} \\
&\quad a [\sigma(\llbracket [u_1]_{\mathbb{S}} \rrbracket^a, \dots, \llbracket [u_m]_{\mathbb{S}} \rrbracket^a)]_{\mathbb{T}} \\
&= \{ \text{IH, where } t_i [s_x/x] \text{ is a separated term equal to } u_i \} \\
&\quad a [\sigma([a [t_1 \llbracket [s_x]_{\mathbb{S}}/x \rrbracket]_{\mathbb{T}}]_{\mathbb{S}}, \dots, [a [t_m \llbracket [s_x]_{\mathbb{S}}/x \rrbracket]_{\mathbb{T}}]_{\mathbb{S}})]_{\mathbb{T}} \\
&= \{ \text{moving the application of } a \text{ to the front} \} \\
&\quad a \circ T S a [\sigma(\llbracket [t_1 \llbracket [s_x]_{\mathbb{S}}/x \rrbracket]_{\mathbb{T}} \rrbracket_{\mathbb{S}}, \dots, \llbracket [t_m \llbracket [s_x]_{\mathbb{S}}/x \rrbracket]_{\mathbb{T}} \rrbracket_{\mathbb{S}})]_{\mathbb{T}}
\end{aligned}$$

$$\begin{aligned}
&= \{ a \circ T S a = a \circ \mu^{TS} \} \\
&\quad a \circ \mu^{TS} [\sigma([[t_1 [[s_x]_{\mathbb{S}}/x]]_{\mathbb{T}}]_{\mathbb{S}}, \dots, [[t_m [[s_x]_{\mathbb{S}}/x]]_{\mathbb{T}}]_{\mathbb{S}})]_{\mathbb{T}} \\
&= \{ \mu T S = \mu^T \mu^S \circ T \lambda S \} \\
&\quad a \circ \mu^T \mu^S \circ T \lambda S [\sigma([[t_1 [[s_x]_{\mathbb{S}}/x]]_{\mathbb{T}}]_{\mathbb{S}}, \dots, [[t_m [[s_x]_{\mathbb{S}}/x]]_{\mathbb{T}}]_{\mathbb{S}})]_{\mathbb{T}} \\
&= \{ \text{unit law for } \lambda : \eta^S T = T \eta^S \} \\
&\quad a \circ \mu^T \mu^S [\sigma([t_1 [[s_x]_{\mathbb{S}}/x]]_{\mathbb{T}}, \dots, [t_m [[s_x]_{\mathbb{S}}/x]]_{\mathbb{T}})]_{\mathbb{T}} \\
&= \{ \text{applying the multiplications} \} \\
&\quad a [\sigma(t_1 [[s_x]_{\mathbb{S}}/x], \dots, t_m [[s_x]_{\mathbb{S}}/x])]_{\mathbb{T}}.
\end{aligned}$$

By the axiom of congruence, $\sigma(t_1 [s_x/x], \dots, t_m [s_x/x])$ is indeed a separated term equal to $\sigma(u_1, \dots, u_m)$. Hence this is what we needed to show.

Now that we understand the mapping $F : \mathcal{C}^{TS} \rightarrow \mathbb{U}^\lambda\text{-Alg}$, we can prove it is indeed a functor:

- F maps objects to objects:

For $(A, [\cdot]^a)$ to be a \mathbb{U}^λ -algebra, $[\cdot]^a$ needs to preserve all the equations in $E^{\mathbb{U}^\lambda}$. Since $E^{\mathbb{U}^\lambda} = E^{\mathbb{S}} \cup E^{\mathbb{T}} \cup E^\lambda$, we check that $[\cdot]^a$ preserves the equations in each of these three sets.

- $s_1 =_{\mathbb{S}} s_2 \in E^{\mathbb{S}}$ is preserved by $[\cdot]^a$:

From Equation (3.1) and the fact that s_1 and s_2 are both separated we know:

$$\begin{aligned}
[[s_1]]^a &= a [[s_1]_{\mathbb{S}}]_{\mathbb{T}} \\
[[s_2]]^a &= a [[s_2]_{\mathbb{S}}]_{\mathbb{T}}.
\end{aligned}$$

Since $s_1 =_{\mathbb{S}} s_2$, we know $[[s_1]_{\mathbb{S}}]_{\mathbb{T}} = [[s_2]_{\mathbb{S}}]_{\mathbb{T}}$, and so indeed:

$$[[s_1]]^a = [[s_2]]^a.$$

- $t_1 =_{\mathbb{T}} t_2 \in E^{\mathbb{T}}$ is preserved by $[\cdot]^a$:

From Equation (3.1) and the fact that t_1 and t_2 are both separated we know that:

$$\begin{aligned}
[[t_1]]^a &= a [t_1 [[x]_{\mathbb{S}}/x]]_{\mathbb{T}} \\
[[t_2]]^a &= a [t_2 [[x]_{\mathbb{S}}/x]]_{\mathbb{T}}.
\end{aligned}$$

Since $t_1 =_{\mathbb{T}} t_2$, $[t_1 [[x]_{\mathbb{S}}/x]]_{\mathbb{T}} = [t_2 [[x]_{\mathbb{S}}/x]]_{\mathbb{T}}$, and so indeed:

$$[[t_1]]^a = [[t_2]]^a.$$

– $s[t_x/x] =_{\mathbb{U}^\lambda} t[s_x/x]$ is preserved by $[\![\cdot]\!]^a$:

From Equation (3.1) we know:

$$[\![s[t_x/x]]\!]^a = a[t'[[s'_{x'}]_{\mathbb{S}}/x']]_{\mathbb{T}}$$

for some separated term $t'[s'_{x'}/x'] =_{\mathbb{U}^\lambda} s[t_x/x]$. By essential uniqueness, we must have that $t'[s'_{x'}/x']$ and $t[s_x/x]$ are equal modulo (\mathbb{S}, \mathbb{T}) and so:

$$[t'[[s'_{x'}]_{\mathbb{S}}/x']]_{\mathbb{T}} = [t[[s_x]_{\mathbb{S}}/x]]_{\mathbb{T}}.$$

Hence:

$$[\![s[t_x/x]]\!]^a = [\![t[s_x/x]]\!]^a.$$

- F maps morphisms to morphisms:

Let $h : (A, a) \rightarrow (B, b)$ be a morphism in \mathcal{C}^{TS} . Then $F(h) : (A, [\![\cdot]\!]^a) \rightarrow (B, [\![\cdot]\!]^b)$ must be a morphism in $\mathbb{U}^\lambda\text{-Alg}$. Since F maps h to itself, all we need to show is that h is a homomorphism in $\mathbb{U}^\lambda\text{-Alg}$. That is, for any $\sigma \in \Sigma^{\mathbb{U}^\lambda}$:

$$h([\![\sigma]^a(x_1, \dots, x_n)]\!] = [\![\sigma]^b(h(x_1), \dots, h(x_n))]\!].$$

There are two cases, $\sigma \in \Sigma^{\mathbb{S}}$ and $\sigma \in \Sigma^{\mathbb{T}}$. We prove these separately.

– $\sigma \in \Sigma^{\mathbb{S}}$.

$$\begin{aligned} & h([\![\sigma]^a(x_1, \dots, x_n)]\!] \\ = & \{ \text{definition of } [\![\cdot]\!]^a \} \\ & h \circ a [[\sigma(x_1, \dots, x_n)]_{\mathbb{S}}]_{\mathbb{T}} \\ = & \{ h \text{ is a morphism in } \mathcal{C}^{TS}, \text{ so: } h \circ a = b \circ TSh \} \\ & b \circ TSh [[\sigma(x_1, \dots, x_n)]_{\mathbb{S}}]_{\mathbb{T}} \\ = & \{ \text{moving the application of } h \text{ inside} \} \\ & b [[\sigma(h(x_1), \dots, h(x_n))]_{\mathbb{S}}]_{\mathbb{T}} \\ = & \{ \text{definition of } [\![\cdot]\!]^b \} \\ & [\![\sigma]^b(h(x_1), \dots, h(x_n))]\!. \end{aligned}$$

– $\sigma \in \Sigma^{\mathbb{T}}$.

$$\begin{aligned} & h([\![\sigma]^a(x_1, \dots, x_n)]\!] \\ = & \{ \text{definition of } [\![\cdot]\!]^a \} \\ & h \circ a [\sigma([x_1]_{\mathbb{S}}, \dots, [x_n]_{\mathbb{S}})]_{\mathbb{T}} \\ = & \{ h \text{ is a morphism in } \mathcal{C}^{TS}, \text{ so: } h \circ a = b \circ TSh \} \\ & b \circ TSh [\sigma([x_1]_{\mathbb{S}}, \dots, [x_n]_{\mathbb{S}})]_{\mathbb{T}} \end{aligned}$$

$$\begin{aligned}
&= \{ \text{moving the application of } h \text{ inside} \} \\
&\quad b [\sigma([h(x_1)]_{\mathbb{S}}, \dots, [h(x_n)]_{\mathbb{S}})]_{\mathbb{T}} \\
&= \{ \text{definition of } \llbracket \cdot \rrbracket^b \} \\
&\quad \llbracket \sigma \rrbracket^b(h(x_1), \dots, h(x_n)).
\end{aligned}$$

- F trivially preserves identities and compositions, since it maps each morphism to itself.

We now define a functor $G : \mathbb{U}^\lambda\text{-Alg} \rightarrow \mathcal{C}^{TS}$ as follows:

- G maps the pair $(A, \llbracket \cdot \rrbracket^A)$ in $\mathbb{U}^\lambda\text{-Alg}$ to the algebra $(A, a_{\llbracket \cdot \rrbracket^A})$, where $a_{\llbracket \cdot \rrbracket^A}$ is defined on $u \in TSX$ as:

$$a_{\llbracket \cdot \rrbracket^A}(u) = \llbracket t[s_x/x] \rrbracket^A,$$

where $t[s_x/x]$ is a representative of u in TS : $u = [t \llbracket [s_x]_{\mathbb{S}}/x \rrbracket]_{\mathbb{T}}$.

- G maps a morphism $h : (A, \llbracket \cdot \rrbracket^A) \rightarrow (B, \llbracket \cdot \rrbracket^B)$, which is a function $A \rightarrow B$, to itself, now interpreted as a morphism $h : (A, a_{\llbracket \cdot \rrbracket^A}) \rightarrow (B, b_{\llbracket \cdot \rrbracket^B})$.

We show that this is indeed a functor.

- G maps objects to objects:

For $(A, a_{\llbracket \cdot \rrbracket^A})$ to be an EM-algebra, we need to show that it satisfies:

$$\begin{aligned}
a_{\llbracket \cdot \rrbracket^A} \circ \eta^{TS} &= Id_{TS} \\
a_{\llbracket \cdot \rrbracket^A} \circ TS a_{\llbracket \cdot \rrbracket^A} &= a_{\llbracket \cdot \rrbracket^A} \circ \mu^{TS}.
\end{aligned}$$

Starting with the unit equation, let x be any element of X , then:

$$\begin{aligned}
&a_{\llbracket \cdot \rrbracket^A} \circ \eta_X^{TS}(x) \\
&= \{ \eta_X^{TS} = \eta_X^T \eta_X^S \} \\
&\quad a_{\llbracket \cdot \rrbracket^A} \circ \eta_X^T \eta_X^S(x) \\
&= \{ \text{applying both units} \} \\
&\quad a_{\llbracket \cdot \rrbracket^A} \llbracket [x]_{\mathbb{S}} \rrbracket_{\mathbb{T}} \\
&= \{ \text{definition of } a_{\llbracket \cdot \rrbracket^A} \} \\
&\quad \llbracket [x] \rrbracket^A \\
&= x.
\end{aligned}$$

Next is the multiplication. Let $u \in TSTSX$ and let $t [s_x [t_y [s_z/z] /y] /x]$ be any representative of u , that is:

$$u = [t [s_x [[t_y [[s_z]_{\mathbb{S}}/z]]_{\mathbb{T}}/y]]_{\mathbb{S}}/x]_{\mathbb{T}}.$$

Then:

$$\begin{aligned} & a_{[\cdot]A} \circ T S a_{[\cdot]A}(u) \\ &= a_{[\cdot]A} \circ T S a_{[\cdot]A} [t [s_x [[t_y [[s_z]_{\mathbb{S}}/z]]_{\mathbb{T}}/y]]_{\mathbb{S}}/x]_{\mathbb{T}} \\ &= \{ \text{moving the application of } a_{[\cdot]A} \text{ inside} \} \\ & a_{[\cdot]A} [t [s_x [a_{[\cdot]A} ([t_y [[s_z]_{\mathbb{S}}/z]]_{\mathbb{T}})/y]]_{\mathbb{S}}/x]_{\mathbb{T}} \\ &= \{ \text{definition of } a_{[\cdot]A} \} \\ & a_{[\cdot]A} [t [s_x [[t_y [s_z/z]]^A /y]]_{\mathbb{S}}/x]_{\mathbb{T}} \\ &= \{ \text{definition of } a_{[\cdot]A} \} \\ & [[t [s_x [[t_y [s_z/z]]^A /y] /x]]^A \\ &= [[t [s_x [t_y [s_z/z] /y] /x]]^A. \end{aligned}$$

On the other hand:

$$\begin{aligned} & a_{[\cdot]A} \circ \mu^{TS}(u) \\ &= a_{[\cdot]A} \circ \mu^T \mu^S \cdot T \lambda S [t [s_x [[t_y [[s_z]_{\mathbb{S}}/z]]_{\mathbb{T}}/y]]_{\mathbb{S}}/x]_{\mathbb{T}} \\ &= \{ \text{if } \lambda [s_x [[t_y]_{\mathbb{T}}/y]]_{\mathbb{S}} = [t'_x [[s'_w]_{\mathbb{S}}/w]]_{\mathbb{T}} \} \\ & a_{[\cdot]A} \circ \mu^T \mu^S [t [t'_x [[s'_w [[s_z]_{\mathbb{S}}/z]]_{\mathbb{S}}/w]]_{\mathbb{T}}/x]_{\mathbb{T}} \\ &= \{ \text{applying the multiplications} \} \\ & a_{[\cdot]A} [t [t'_x [[s'_w [s_z/z]]_{\mathbb{S}}/w] /x]]_{\mathbb{T}} \\ &= \{ \text{definition of } a_{[\cdot]A} \} \\ & [[t [t'_x [s'_w [s_z/z] /w] /x]]^A. \end{aligned}$$

To finish the proof of the multiplication axiom, we need to show that:

$$[[t [s_x [t_y [s_z/z] /y] /x]]^A = [[t [t'_x [s'_w [s_z/z] /w] /x]]^A$$

Since $\lambda [s_x [[t_y]_{\mathbb{T}}/y]]_{\mathbb{S}} = [t'_x [[s'_w]_{\mathbb{S}}/w]]_{\mathbb{T}}$, we know that:

$$s_x [t_y/y] =_{\mathbb{U}^\lambda} t'_x [s'_w/w],$$

and hence by substitution and congruence:

$$t [s_x [t_y [s_z/z] /y] /x] =_{\mathbb{U}^\lambda} t [t'_x [s'_w [s_z/z] /w] /x].$$

Therefore:

$$\llbracket t [s_x [t_y [s_z/z] /y] /x] \rrbracket^A = \llbracket t [t'_x [s'_w [s_z/z] /w] /x] \rrbracket^A,$$

which proves that $a_{\llbracket \cdot \rrbracket^A} \circ TSh a_{\llbracket \cdot \rrbracket^A} = a_{\llbracket \cdot \rrbracket^A} \circ \mu^{TS}$.

- G maps morphisms to morphisms:

Let $h : (A, \llbracket \cdot \rrbracket^A) \rightarrow (B, \llbracket \cdot \rrbracket^B)$ be a morphism in $\mathbb{U}^\lambda\text{-Alg}$. Then $G(h) : (A, a_{\llbracket \cdot \rrbracket^A}) \rightarrow (B, b_{\llbracket \cdot \rrbracket^B})$ must be a morphism in \mathcal{C}^{TS} . Since G maps h to itself, all we need to show is that $h \circ a_{\llbracket \cdot \rrbracket^A} = b_{\llbracket \cdot \rrbracket^B} \circ TSh$:

$$\begin{aligned} & h \circ a_{\llbracket \cdot \rrbracket^A} [t \llbracket [s_x]_{\mathbb{S}} /x \rrbracket_{\mathbb{T}}] \\ &= \{ \text{definition of } a_{\llbracket \cdot \rrbracket^A} \} \\ & \quad h(\llbracket t [s_x/x] \rrbracket^A) \\ &= \{ \text{property of } \llbracket \cdot \rrbracket^A \} \\ & \quad \llbracket t [s_x [h(y)/y] /x] \rrbracket^B \\ &= \{ \text{definition of } b_{\llbracket \cdot \rrbracket^B} \} \\ & \quad b_{\llbracket \cdot \rrbracket^B} [t \llbracket [s_x [h(y)/y]_{\mathbb{S}} /x \rrbracket_{\mathbb{T}}] \\ &= \{ \text{moving } h \text{ to the front} \} \\ & \quad b_{\llbracket \cdot \rrbracket^B} \circ TSh [t \llbracket [s_x]_{\mathbb{S}} /x \rrbracket_{\mathbb{T}}]. \end{aligned}$$

- G trivially preserves identities and compositions.

The last step in this proof is showing that both $F \circ G = Id_{\mathbb{U}^\lambda\text{-Alg}}$ and $G \circ F = Id_{\mathcal{C}^{TS}}$. We only show this property for objects; it is trivial for the morphisms since both F and G map each morphism to itself. First we show that $F \circ G = Id_{\mathbb{U}^\lambda\text{-Alg}}$:

$$\begin{aligned} F \circ G (A, \llbracket \cdot \rrbracket^A) &= F (A, a_{\llbracket \cdot \rrbracket^A}) \\ &= (A, \llbracket \cdot \rrbracket^{a_{\llbracket \cdot \rrbracket^A}}). \end{aligned}$$

So we need to show that $\llbracket \cdot \rrbracket^A = \llbracket \cdot \rrbracket^{a_{\llbracket \cdot \rrbracket^A}}$:

$$\begin{aligned} & \llbracket \sigma(x_1, \dots, x_n) \rrbracket^{a_{\llbracket \cdot \rrbracket^A}} \\ &= \{ \text{definition of } \llbracket \cdot \rrbracket^{a_{\llbracket \cdot \rrbracket^A}} \} \\ & \quad \begin{cases} a_{\llbracket \cdot \rrbracket^A} \llbracket \llbracket \sigma(x_1, \dots, x_n) \rrbracket_{\mathbb{S}} \rrbracket_{\mathbb{T}}, & \text{if } \sigma \in \Sigma^{\mathbb{S}} \\ a_{\llbracket \cdot \rrbracket^A} \llbracket \llbracket \sigma([x_1]_{\mathbb{S}}, \dots, [x_n]_{\mathbb{S}}) \rrbracket_{\mathbb{T}} \rrbracket_{\mathbb{T}}, & \text{if } \sigma \in \Sigma^{\mathbb{T}} \end{cases} \end{aligned}$$

$$\begin{aligned}
&= \{ \text{definition of } a_{\llbracket \cdot \rrbracket^A}. \} \\
&\quad \begin{cases} \llbracket \sigma(x_1, \dots, x_n) \rrbracket^A, & \text{if } \sigma \in \Sigma^{\mathbb{S}} \\ \llbracket \sigma(x_1, \dots, x_n) \rrbracket^A, & \text{if } \sigma \in \Sigma^{\mathbb{T}} \end{cases} \\
&= \{ \text{definition of } \llbracket \cdot \rrbracket^A \} \\
&\quad \llbracket \sigma(x_1, \dots, x_n) \rrbracket^A.
\end{aligned}$$

Then we show that $G \circ F = Id_{\text{EMTS}}$:

$$\begin{aligned}
G \circ F (A, a) &= G (A, \llbracket \cdot \rrbracket^a) \\
&= (A, a_{\llbracket \cdot \rrbracket^a}).
\end{aligned}$$

So we need to show that $a = a_{\llbracket \cdot \rrbracket^a}$:

$$\begin{aligned}
&a_{\llbracket \cdot \rrbracket^a} [t \llbracket [s_x]_{\mathbb{S}}/x \rrbracket_{\mathbb{T}}] \\
&= \{ \text{definition of } a_{\llbracket \cdot \rrbracket^a} \} \\
&\quad \llbracket t [s_x/x] \rrbracket^a \\
&= \{ \text{definition of } \llbracket \cdot \rrbracket^a \} \\
&\quad a [t \llbracket [s_x]_{\mathbb{S}}/x \rrbracket_{\mathbb{T}}].
\end{aligned}$$

We may conclude that \mathcal{C}^{TS} and $\mathbb{U}^\lambda\text{-Alg}$ are isomorphic categories. \square

Theorems 3.7 and 3.9 together give us a concrete presentation for composite theories.

Corollary 3.10. *Let \mathbb{S} and \mathbb{T} be algebraic theories with presentations $(\Sigma^{\mathbb{S}}, E^{\mathbb{S}})$ and $(\Sigma^{\mathbb{T}}, E^{\mathbb{T}})$ respectively. Let \mathbb{U} be a composite theory of \mathbb{T} after \mathbb{S} . Then the following gives a presentation of \mathbb{U} :*

$$\begin{aligned}
\Sigma^{\mathbb{U}} &= \Sigma^{\mathbb{S}} \uplus \Sigma^{\mathbb{T}} \\
E^{\mathbb{U}} &= E^{\mathbb{S}} \cup E^{\mathbb{T}} \cup E^\lambda,
\end{aligned}$$

where E^λ consists of all provable equations in \mathbb{U} of form $s[t_x/x] = t[s_y/y]$.

Chapter 4

Characterising Idempotent Monads via Distributive Laws

Self-composition of monads is a fascinating subject that is often overlooked. We have already seen that the multiset monad distributes over itself (see Example 2.14), whereas the powerset monad does not self-compose at all [35], indicating that this is not a trivial subject.

It is tempting to believe that any monad will distribute over itself, because of the type of such a distributive law: $TT \Rightarrow TT$. There is an obvious natural transformation of that type: the identity! However, a quick check of the axioms shows that the identity cannot be a distributive law for most common monads. It fails for instance for monads such as multiset, list, probability distribution, etc. And so the idea of having the identity as a distributive law is quickly dismissed. But what if we take this naive idea seriously: could the identity natural transformation ever function as a distributive law?

In this chapter we show that the identity can only be a distributive law in the trivial case of self-composing an idempotent monad. In fact, having the identity as a self-distributive law is *equivalent* to being an idempotent monad. In addition, we show that two other obvious candidates for a distributive law characterise idempotent monads as well, namely $\eta T \circ \mu$ and $T\eta \circ \mu$.

In the following chapters we will return to the subject of self-distribution, showing that the list monad and the probability distribution monads do not distribute over themselves in Chapter 5 and using self-distribution as inspiration in Chapter 6.

4.1 Idempotent Monads

Idempotent monads are monads which, when applied twice, do the same as if they were applied just once.

$$T \circ T = T.$$

Idempotent monads can be characterised as follows [9]. A monad $\langle T, \eta, \mu \rangle$ is idempotent iff any of the following six statements are true:

- [1] The multiplication μ is a natural isomorphism.
- [2] All components of μ are monomorphisms.
- [3] The natural transformations ηT and $T\eta$ are equal.
- [4] For every algebra (X, h) in the Eilenberg-Moore category \mathcal{C}^T , the action $h : TX \rightarrow X$ is an isomorphism.
- [5] The forgetful functor $\mathcal{C}^T \rightarrow \mathcal{C}$ is full and faithful.
- [6] There exists a pair of adjoint functors $F \dashv U$ such that the induced monad $(UF, U\epsilon F)$ is isomorphic to (T, μ) and U is full and faithful.

Example 4.1. Reflective subcategories give rise to idempotent monads, since the reflector acts as a kind of completion operation. Completing a structure twice is the same as completing it once, which hence causes the idempotence of the monad. This is captured by the fifth characterisation above; the reflective subcategory is categorically equivalent to the Eilenberg-Moore category of the idempotent monad. For example, the category of Abelian groups, **Ab**, is a reflective subcategory of the category of groups, **Gp**. The embedding-reflection adjunction gives the idempotent monad. The embedding includes **Ab** into **Gp** and the reflection sends each group to its Abelianisation.

We will now add the following characterisations to the list:

- [7] *The identity natural transformation $Id : TT \Rightarrow TT$ is a distributive law for T over itself.*
- [8] *The natural transformation $\eta T \circ \mu : TT \Rightarrow TT$ is a distributive law for T over itself.*
- [9] *The natural transformation $T\eta \circ \mu : TT \Rightarrow TT$ is a distributive law for T over itself.*

4.2 The Identity as Distributive Law

Theorem 4.2. *For a monad T , the identity $Id : TT \Rightarrow TT$ is a distributive law for T over itself iff T is an idempotent monad.*

Proof. We will give this proof diagrammatically. Let T be a monad with unit η and multiplication μ . Recall that in string diagrams, η is denoted by a lollipop $\begin{array}{c} \circ \\ | \end{array}$ and μ by a fork $\begin{array}{c} \cup \\ | \end{array}$, and diagrams are read from top to bottom.

Suppose that the identity natural transformation $Id : TT \Rightarrow TT$ is a distributive law. We will indicate the appearance of this distributive law in a diagram by dashed boxes around identity wires.

The unit axioms of a distributive law then tell us that:

and

In other words, the maps $T\eta$ and ηT are equal, which is one of the characterisations of an idempotent monad.

Now suppose that T is an idempotent monad. We need to show that the identity natural transformation is a distributive law. Since T being idempotent means that the maps $T\eta$ and ηT are equal, the unit axioms are satisfied. For the multiplication axioms, we need to show that:

and

Both of these simplify to the identity:

Since T is idempotent, μ is a natural isomorphism, and therefore:

This proves both the multiplication axioms, showing that the identity is indeed a distributive law for an idempotent monad. \square

4.3 Two Other Extreme Cases of Distributive Laws

Theorem 4.3. *For a monad T , the natural transformations $T\eta \circ \mu$ and $\eta T \circ \mu$ are distributive laws of type $TT \Rightarrow TT$ iff T is an idempotent monad.*

Proof. Again, the proof is in terms of diagrams. We will only show the proof for $T\eta \circ \mu$, as the proof for $\eta T \circ \mu$ is similar.

Assume that $T\eta \circ \mu : TT \Rightarrow TT$ is a distributive law. Then by one of the unit axioms for distributive laws (first equality) and one of the unit axioms for monads (second equality), we have:

So $\eta T = T\eta$, proving that T is an idempotent monad.

Now suppose that T is an idempotent monad. Then by one of the unit axioms for monads (first equality), and the fact that $T\eta = \eta T$ for idempotent monads (second equality), we have:

which proves the first unit axiom of a distributive law. The second one is shown similarly:

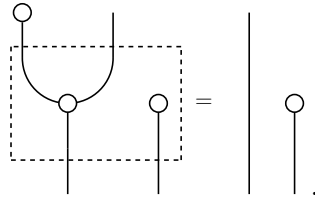

For the multiplication axioms, we need to show that:

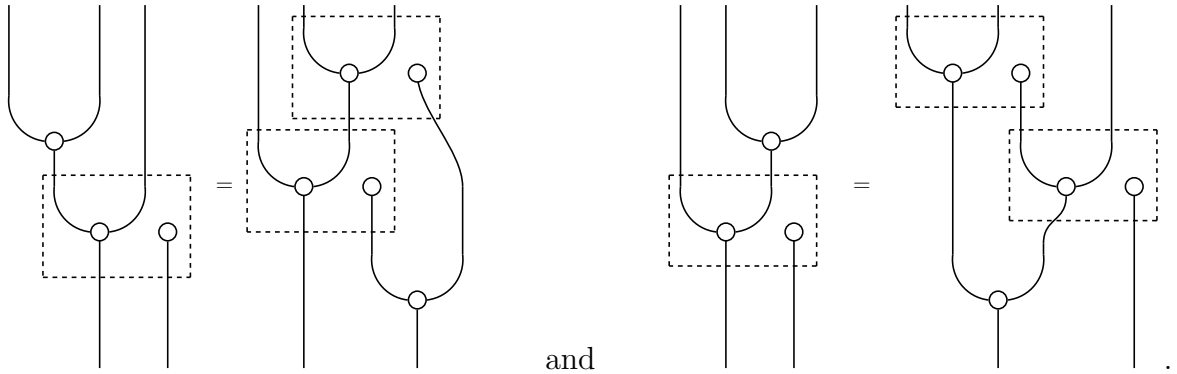

For both, we need an application of one of the unit axioms of a monad (first equality) and associativity of the multiplication (second equality). We prove the first multiplication axiom of a distributive law:

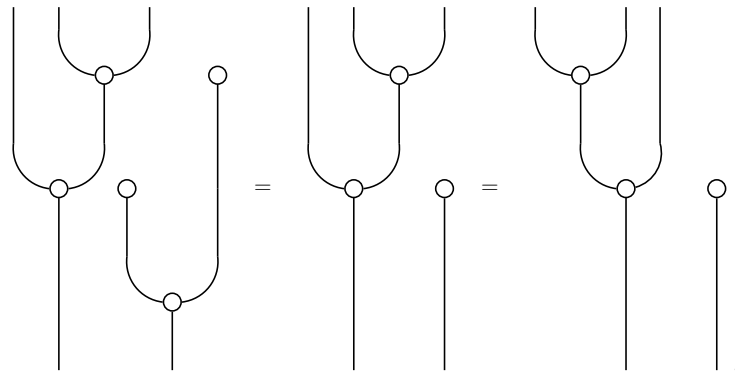

and the second:

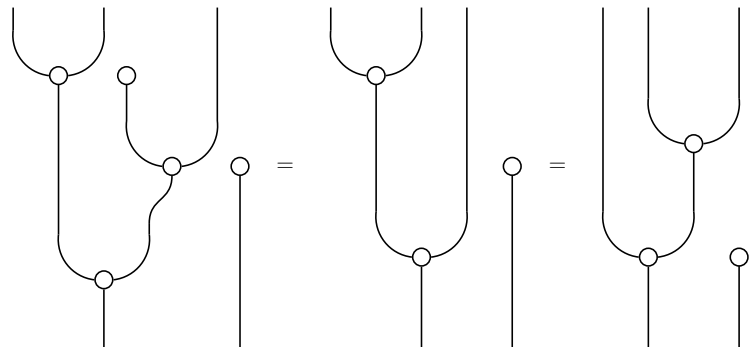

This proves that $T\eta \circ \mu : TT \Rightarrow TT$ is a distributive law. □

Now that we have seen some distributive laws that only work for the trivial monad composition of an idempotent monad with itself, we will start looking at proofs showing when no distributive laws are possible at all.

Chapter 5

No-Go Theorems for Distributive Laws

The ultimate goal of this line of research is to understand monad compositions completely: to know exactly which properties are necessary and sufficient for monads to compose via distributive laws. Significant progress has been made on the side of positive results, where certain properties of monads were found to be *sufficient* for the existence of a distributive law. The most well-known result of this type is by Manes and Mulry, stating that commutative monads distribute over monads that are presented by theories with only linear equations [44].

However, the properties found so far have not been proven to be *necessary* for monads to compose. One way to close this gap in knowledge is to prove which properties are sufficient for monad compositions to fail. These are the type of results that we study in this chapter.

The literature contains a few counterexamples of specific monads that do not compose via a distributive law. Plotkin famously proved that there is no distributive law for the powerset monad over the probability distribution monad $DP \Rightarrow PD$ [60], and a few other counterexamples involving the powerset monad have followed since [35, 61]. However, no general theorems matching Manes and Mulry’s positive results have showed up in the literature¹.

We found that by viewing monads algebraically rather than categorically, such general negative results are much easier to produce. In this chapter we show the theorems (and proofs) this algebraic viewpoint has produced so far. In Chapter 7 we analyse the method used in the proofs of this chapter, extracting a ‘template’ for an algebraic no-go theorem. We then compare the algebraic and categorical approaches.

¹The results by Klin and Salamanca are more general than Plotkin’s counterexample, but they remain limited to the specific case of the powerset monad.

5.1 Multiplicative Zeroes

The algebraic equivalent of a distributive law is a composite theory. To prove algebraically that there is no distributive law between two monads, we therefore have to show that there is no composite theory of their algebraic theories. We prove this by contradiction. We assume that there is a composite theory, and then show that this assumption is incompatible with various properties the two component theories may have. Proposition 3.4, the proposition stating various equivalent formulations of composite theories, will play a vital role in our proofs.

We start with a short but important proposition, which will form a key step in several no-go theorems in this thesis. Although it is not a full no-go theorem, it illustrates how we use the two properties of composite theories (separation and essential uniqueness) in our proofs.

We aim to generalise the concept of a multiplicative zero, which annihilates any term it appears in:

$$x * 0 = 0.$$

In the theory of rings, 0 comes from the theory of Abelian groups, and is substituted for y in the term $x * y$, which comes from the theory of monoids, see Example 2.13. Generalising this, we will look at a composite theory \mathbb{U} of theories \mathbb{T} after \mathbb{S} . Then we take a constant $e_{\mathbb{T}}$ from \mathbb{T} , and substitute it into a term s from \mathbb{S} , which yields a term of form $s[e_{\mathbb{T}}/x_i]$, where x_i is one of the variables appearing in s . The goal is then to find conditions for the theories \mathbb{S} and \mathbb{T} such that:

$$s[e_{\mathbb{T}}/x_i] =_{\mathbb{U}} e_{\mathbb{T}}.$$

The proposition captures the conditions of \mathbb{S} and \mathbb{T} that we found to imply this equation in any composite theory of \mathbb{T} after \mathbb{S} . We have formulated these conditions in their most general form, to ensure that the proposition has a wide applicability. An explanation of them can be found immediately below the proposition itself.

Proposition 5.1. *Let \mathbb{S} be an algebraic theory with an n -ary term s ($n \geq 1$) such that:*

- *There is a substitution $f : \text{var}(s) \rightarrow \mathbb{S}$ such that for any $x \in \text{var}(s)$:*

$$\Gamma \vdash s[f(y)/y \neq x] =_{\mathbb{S}} x.$$

And let \mathbb{T} be an algebraic theory with a constant $e_{\mathbb{T}}$ such that:

- For all terms $X \vdash t'$ and any variable substitution $f : X \rightarrow Y$:

$$Y \vdash t'[f] =_{\mathbb{T}} e_{\mathbb{T}} \quad \Rightarrow \quad X \vdash t' =_{\mathbb{T}} e_{\mathbb{T}}.$$

If \mathbb{U} is a composite theory of \mathbb{T} after \mathbb{S} , then we must have that, for any $x_i \in \text{var}(s)$:

$$s[e_{\mathbb{T}}/x_i] =_{\mathbb{U}} e_{\mathbb{T}}.$$

Remark 5.2 (Interpretation of Axioms). The assumption for \mathbb{S} is a generalisation of idempotence and unitality. It requires that terms can be reduced to variables via a suitable substitution. Idempotence and unitality are both instances of this. Idempotence requires the substitution to change all variables to x :

$$s(x, y)[x/x, x/y] = s(x, x) = x,$$

while unitality uses a substitution of a constant for all but one variable:

$$s(x, y)[e_s/y] = s(x, e_s) = x.$$

Notice that any variable (seen as a term in \mathbb{S}) satisfies this assumption, and trivially satisfies the conclusion of this proposition as well.

The assumption for the theory \mathbb{T} states that if a variable substitution of term t' is provably equal to a constant, then t' is already provably equal to that constant. Since variable substitutions exclude constants from being substituted into a term, this is quite a common property in algebraic theories. It does, however, exclude equations such as:

$$t(x, x, z) = z,$$

because $t(x, y, e_{\mathbb{T}})$ would be non-reducible, but:

$$t(x, y, e_{\mathbb{T}})[x/y] = t(x, x, e_{\mathbb{T}}) = e_{\mathbb{T}}.$$

So unless the term $t(x, y, e_{\mathbb{T}})$ is reducible to $e_{\mathbb{T}}$, this would violate the assumption stated for \mathbb{T} in the proposition.

We will now prove the proposition.

Proof. Let \mathbb{S} and \mathbb{T} be theories with the properties indicated above, let \mathbb{U} be any composite theory of \mathbb{T} after \mathbb{S} , and let s be any term in \mathbb{S} satisfying the requirement stated in the proposition. The conclusion of the proposition is trivial in the case that s has only one free variable, because our assumption for \mathbb{S} implies that we must have $s(x) =_{\mathbb{S}} x$. We may therefore assume that s has at least two free variables.

Consider the term $s[e_{\mathbb{T}}/x_i]$ in \mathbb{U} , where x_i is an arbitrary variable appearing in s and $e_{\mathbb{T}}$ is a constant of \mathbb{T} . Separation tells us that every term in a composite theory is equal to a separated term. Since $s[e_{\mathbb{T}}/x_i]$ is not separated, there is a term t' in \mathbb{T} and there are terms s'_x in \mathbb{S} such that:

$$s[e_{\mathbb{T}}/x_i] =_{\mathbb{U}} t'[s'_x/x].$$

We use substitutions to manipulate $s[e_{\mathbb{T}}/x_i]$ into a separated term. The substitution f given by the assumption for \mathbb{S} makes this easy to do:

$$e_{\mathbb{T}} =_{\mathbb{U}} s[e_{\mathbb{T}}/x_i][f(y)/y \neq x_i] =_{\mathbb{U}} t'[s'_x[f(y)/y \neq x_i]/x].$$

Hence:

$$e_{\mathbb{T}} =_{\mathbb{U}} t'[s'_x[f(y)/y \neq x_i]/x].$$

We now have two separated terms equal to each other, so we can use essential uniqueness to conclude that there are variable substitutions g_1, g_2 such that:

$$e_{\mathbb{T}}[g_1] =_{\mathbb{T}} t'[g_2]. \quad (\text{Proposition 3.4, 3a})$$

Of course g_1 has no effect on the constant $e_{\mathbb{T}}$, which has no variables to substitute. Since g_2 is a variable substitution, we can apply the assumption for \mathbb{T} , and conclude that $t' =_{\mathbb{T}} e_{\mathbb{T}}$. Going back to our original equation:

$$\begin{aligned} s[e_{\mathbb{T}}/x_i] &=_{\mathbb{U}} t'[s'_x/x] \\ \Rightarrow \quad \{ t' =_{\mathbb{T}} e_{\mathbb{T}} \} \\ s[e_{\mathbb{T}}/x_i] &=_{\mathbb{U}} e_{\mathbb{T}}[s'_x/x] \\ \Rightarrow \quad \{ e_{\mathbb{T}} \text{ has no variables} \} \\ s[e_{\mathbb{T}}/x_i] &=_{\mathbb{U}} e_{\mathbb{T}}, \end{aligned}$$

which is what we needed to show. □

Remark 5.3. If all terms in \mathbb{S} with ≥ 1 free variables satisfy the assumption stated in the proposition, then the constant $e_{\mathbb{T}}$ in \mathbb{T} annihilates any \mathbb{S} -term it appears in. We then say that $e_{\mathbb{T}}$ acts as a multiplicative zero in the composite theory.

If \mathbb{T} has more than one constant, this immediately leads to an inconsistency. We make this precise in our first no-go theorem.

Theorem 5.4 (No-Go Theorem: Too Many Constants). *Let \mathbb{S} be an algebraic theory with an n -ary term s , where $n \geq 2$, such that:*

- *There is a substitution $f : \text{var}(s) \rightarrow \mathbb{S}$ such that for any $x \in \text{var}(s)$:*

$$\Gamma \vdash s[f(y)/y \neq x] =_{\mathbb{S}} x.$$

And let \mathbb{T} be an algebraic theory with at least two constants e_1, e_2 such that for both constants:

- *For all terms $X \vdash t'$ and any variable substitution $f : X \rightarrow Y$:*

$$Y \vdash t'[f] =_{\mathbb{T}} e_i \quad \Rightarrow \quad X \vdash t' =_{\mathbb{T}} e_i,$$

where $e_i \in \{e_1, e_2\}$.

Then there exists no composite theory of \mathbb{T} after \mathbb{S} .

Proof. Suppose that \mathbb{U} is a composite theory of \mathbb{T} after \mathbb{S} , let e_1 and e_2 be distinct constants in \mathbb{T} , and let s be a term in \mathbb{S} satisfying the stated assumption. Suppose that $\{x, y\} \subseteq \text{var}(s)$. Then by Proposition 5.1 we have:

$$e_1 =_{\mathbb{U}} s[e_1/x, e_2/y] =_{\mathbb{U}} e_2.$$

By essential uniqueness we may conclude that:

$$e_1 =_{\mathbb{T}} e_2. \quad (\text{Proposition 3.4, 3a})$$

Contradiction. So \mathbb{U} cannot be a composite of \mathbb{T} after \mathbb{S} . □

The following corollary reflects our interest in monads. It relies on the one-to-one connection between composite theories and distributive laws explained in Chapter 3.

Corollary 5.5. *If monads S and T have presentations \mathbb{S} and \mathbb{T} such that the conditions of Theorem 5.4 are satisfied, then there is no distributive law of type $S \circ T \Rightarrow T \circ S$.*

Each of our subsequent no-go theorems will have a similar corollary, but we will not state these explicitly. Instead, we will use the statement “no composite theory exists for theory \mathbb{T} after \mathbb{S} ” as a synonym for “no distributive law of type $S \circ T \Rightarrow T \circ S$ exists”, where S is the free model monad of \mathbb{S} and T is the free model monad of \mathbb{T} .

Example 5.6 (Iterated Distributive Laws). Theorem 5.4 is remarkably useful for determining whether iterated distributive laws are possible. Recall from Chapter 2, Section 2.2.3, that three or more monads can be composed by composing pairwise distributive laws if these distributive laws satisfy the Yang-Baxter equation. Theorem 5.4 approaches the question of iterated distributive laws from the other end, by severely limiting the possibilities. If in a proposed composition of monads $C \circ B \circ A$, the monads B and C each have a constant (and the other mild requirements of Theorem 5.4 are satisfied), then there is no distributive law $A \circ (C \circ B) \Rightarrow (C \circ B) \circ A$, and hence any possible pairwise distributive laws will not satisfy Yang-Baxter.

We give a few concrete examples involving the list, multiset and powerset monads L, M, P , whose algebraic theories are monoids, commutative monoids, and join semi-lattices respectively (see Example 2.32). We know from Manes and Mulry [44, Theorem 4.3.4] that we can form the monads $M \circ L$, $M \circ M$, and $M \circ P$ via distributive laws. All of these monads have two constants, which satisfy the condition for \mathbb{T} in Theorem 5.4. By picking the term $x * y$ in each of the theories for L , M , and P , we see that these monads satisfy the condition for \mathbb{S} . We can therefore exclude all of the following compositions via distributive laws:

Table 5.1: Overview of possible distributive laws of type:
row \circ column \Rightarrow column \circ row, involving the monads
list (L), multiset (M), and powerset (P).

	$M \circ L$	$M \circ M$	$M \circ P$
L	×	×	×
M	×	×	×
P	×	×	×

Example 5.7 (An Error in the Literature). We saw in the previous example that the term $x * y$ from monoids (the list monad) satisfies the conditions for \mathbb{S} in Theorem 5.4. The exception monad satisfies the conditions for \mathbb{T} with each of its exceptions, so when the exception monad has more than one exception, Theorem 5.4 states that there is no distributive law $L \circ (- + E) \Rightarrow (- + E) \circ L$.

However, Manes and Mulry claim to have a distributive law of this type for the case where $E = \{a, b\}$ [45, Example 4.12], given by:

$$\begin{aligned}\lambda[] &= [] \\ \lambda[e] &= e \text{ for any exception } e \in E \\ \lambda L &= L \text{ if no element of } L \text{ is in } E \\ \lambda L &= a \text{ otherwise.}\end{aligned}$$

We check more concretely that this cannot be a distributive law by showing that it fails the first multiplication axiom from Definition 2.10:

$$\begin{array}{ccc} [[b], []] & \xrightarrow{L(\lambda_X)} & [b, []] \xrightarrow{\lambda_{LX}} a \\ \downarrow \mu_{EX}^L & & \downarrow E(\mu_X^L) \\ [b] & \xrightarrow{\lambda_X} & b \neq a \end{array}$$

The given distributive law follows directly from Manes and Mulry's Theorem 4.6 [45]. We suspect that the problem originates in Lemma 4.5 of this paper. Louis Parlant found that the proof of this lemma might use the isomorphism $(A \otimes I) \cong A$ implicitly if the signature of the theory has constants, while the lemma explicitly does not assume any monoidal properties of its functors. So the lemma, and hence also Theorem 4.6, may not be valid in the case that the theory has constants. In addition, the induction in the proof of Lemma 4.5 starts at $n = 1$, where n is the number of variables appearing in a term. This induction therefore excludes constants, which should be considered separately but are absent from the proof.

It is important to notice that Theorem 5.4 does not contradict the well-known result that the exception monad distributes over every set monad T ; that result is for the other direction $(- + E) \circ T \Rightarrow T \circ (- + E)$.

Non-Example 5.8 (Exception Monad). It is well known that the exception monad distributes over itself. In the algebraic theory for the exception monad, the only terms are constants and variables. Since there are no terms with two or more free variables, it fails the condition required for \mathbb{S} in Theorem 5.4, and hence this theorem does not prevent a distributive law for the exception monad over itself.

Theorem 5.4 is a direct and useful consequence of Proposition 5.1, providing us with many examples of non-existent distributive laws. In the following sections, we will see more applications of Proposition 5.1.

5.2 Inverses and Absorption: Playing with Variables

In this section, we use Proposition 5.1 to solve a question posed by Beck in his original paper about distributive laws: “Does the Abelian group monad distribute over the list monad?” [5]. We then generalise this example and find two no-go theorems, Theorem 5.10 and Theorem 5.14. These theorems are based on the equations of inverses and absorption respectively:

$$\begin{aligned} x + (-x) &= 0 && \text{(inverse)} \\ x \vee (x \wedge y) &= x && \text{(absorption)} \end{aligned}$$

5.2.1 No Distribution of Plus over Times

Can addition distribute over multiplication? Beck considered this question after introducing the classical example of distributive laws, which builds the ring monad from the list monad L , and the Abelian group monad A . The composition uses a distributive law of type $L \circ A \Rightarrow A \circ L$, which exploits the arithmetic distribution of multiplication over addition, see Example 2.13. Beck’s question effectively reverses the direction of distribution, asking whether a distributive law of type $A \circ L \Rightarrow L \circ A$ is possible. Beck’s intuition is that such a distributive law “would have the air of a universal solution to the problem of factoring polynomials into linear factors”. He suggests $L \circ A$ “has little chance of being a triple” [5, Example 4.1]. Unsurprisingly, Beck’s intuition is correct, and no such distributive law exists.

Counterexample 5.9. There is no distributive law of type $A \circ L \Rightarrow L \circ A$, distributing the Abelian Group monad over the list monad.

Proof. The theory of Abelian groups \mathbb{A} , yielding the Abelian group monad A , has presentation:

- Signature: $\Sigma^{\mathbb{A}} = \{0^{(0)}, -(\cdot)^{(1)}, +^{(2)}\}$.
- Equations: $E^{\mathbb{A}}$ contains the equations stating that 0 is the unit of $+$, $+$ is associative and commutative, and $-x$ is the additive inverse of x : $x + (-x) = 0$.

The theory of monoids \mathbb{M} , yielding the list monad L , has presentation:

- Signature: $\Sigma^{\mathbb{M}} = \{1^{(0)}, *^{(2)}\}$.
- Equations: $E^{\mathbb{M}}$ contains the equations stating that 1 is unit of $*$, and $*$ is associative.

The term $x + y$ in \mathbb{A} satisfies the conditions for \mathbb{S} in Proposition 5.1, and \mathbb{M} satisfies the conditions for \mathbb{T} . We conclude that in any composite theory \mathbb{U} of \mathbb{M} after \mathbb{A} , the following equation must hold:

$$x + 1 =_{\mathbb{U}} 1.$$

We prove that this implies that $x =_{\mathbb{U}} 0$:

$$\begin{aligned} & x \\ \stackrel{=_{\mathbb{U}}}{=} & \{ \text{unit} \} \\ & x + 0 \\ \stackrel{=_{\mathbb{U}}}{=} & \{ \text{inverse} \} \\ & x + (1 + (-1)) \\ \stackrel{=_{\mathbb{U}}}{=} & \{ \text{associativity} \} \\ & (x + 1) + (-1) \\ \stackrel{=_{\mathbb{U}}}{=} & \{ x + 1 =_{\mathbb{U}} 1 \} \\ & 1 + (-1) \\ \stackrel{=_{\mathbb{U}}}{=} & \{ \text{inverse} \} \\ & 0. \end{aligned}$$

Hence for any two variables: $x =_{\mathbb{U}} 0 =_{\mathbb{U}} y$, which means that any composite theory U is inconsistent. Since the component theories \mathbb{M} and \mathbb{A} are consistent, Proposition 3.5 tells us that there is no such composite theory. \square

This proof perfectly illustrates the usefulness of an algebraic approach. Beck's question has been open for 50 years, but the proof above involves algebraic manipulations that are near trivial. The key lies in gaining the right perspective. Having access to Proposition 5.1 made all the difference. Proposition 5.1 itself is proven by a fairly simple argument involving separation and essential uniqueness, the key properties of a composite theory.

The result of Counterexample 5.9 is an instance of a more general theorem, which we will prove in the next section.

5.2.2 Generalisations

We consider two variations on the inverse equation $x + (-x) = 0$. The first is a direct generalisation:

$$s = e_{\mathbb{S}},$$

where s is a term containing at least one variable and $e_{\mathbb{S}}$ is a constant. The second variation replaces the constant with a term s' with variables, but such that at least one variable in s does not appear in s' :

$$s = s'.$$

An example of such an equation is the absorption rule for lattices: $x \vee (x \wedge y) = x$.

These two equations give rise to two no-go theorems, which can both be seen as generalisations of Counterexample 5.9. Just as in the counterexample, all the work involving composite theories and essential uniqueness is concentrated in Proposition 5.1. The rest of the proof is just clever, but standard, algebraic manipulation of terms. The first theorem, requiring the equation $s = e_{\mathbb{S}}$, is the most direct generalisation of Counterexample 5.9.

Notice that the proof of Counterexample 5.9 used associativity. We could have avoided this by using the following alternative, but less intuitive, reasoning that applies Proposition 5.1 twice:

$$\begin{aligned}
 & x \\
 =_{\mathbb{U}} & \quad \{ \text{unit} \} \\
 & x + 0 \\
 =_{\mathbb{U}} & \quad \{ \text{inverse} \} \\
 & x + (1 + (-1)) \\
 =_{\mathbb{U}} & \quad \{ \text{substitution} \} \\
 & x + (1 + y)[-1/y] \\
 =_{\mathbb{U}} & \quad \{ \text{Proposition 5.1: } 1 + y =_{\mathbb{U}} 1 \} \\
 & x + 1[-1/y] \\
 =_{\mathbb{U}} & \quad \{ \text{no variable } y \} \\
 & x + 1 \\
 =_{\mathbb{U}} & \quad \{ \text{Proposition 5.1: } x + 1 =_{\mathbb{U}} 1 \} \\
 & 1.
 \end{aligned}$$

This argumentation uses fewer assumptions, so this is the proof we generalise below.

Theorem 5.10 (No-Go Theorem: Inverse Trouble). *Let \mathbb{S} be an algebraic theory such that:*

(S1) \mathbb{S} has a constant $e_{\mathbb{S}}$.

(S2) \mathbb{S} has a term s of arity ≥ 2 such that $e_{\mathbb{S}}$ is a unit of s , that is, for any variable $x \in \text{var}(s)$:

$$s[e_{\mathbb{S}}/y \neq x] =_{\mathbb{S}} x.$$

(S3) \mathbb{S} satisfies an equation of form

$$X \vdash s' =_{\mathbb{S}} e_{\mathbb{S}},$$

with $\text{var}(s') \neq \emptyset$, and s' can be written as $s''[s_i/x_i]$, such that $\text{var}(s'') \cap \text{var}(s') \neq \emptyset$, and there is a substitution $f : \text{var}(s'') \rightarrow \mathbb{S}$ such that for any $x \in \text{var}(s'')$:

$$\Gamma \vdash s''[f(y)/y \neq x] =_{\mathbb{S}} x.$$

Let \mathbb{T} be an algebraic theory such that:

(T1) \mathbb{T} has a constant $e_{\mathbb{T}}$.

(T2) For all terms t' and any variable substitution $f : X \rightarrow Y$:

$$Y \vdash t'[f] =_{\mathbb{T}} e_{\mathbb{T}} \quad \Rightarrow \quad X \vdash t' =_{\mathbb{T}} e_{\mathbb{T}}.$$

Then there does not exist a composite theory of \mathbb{T} after \mathbb{S} .

Remark 5.11 (Interpretation of Axioms). Axiom (S3) is the most difficult to parse. It is designed to generalise the proof technique illustrated above. We used the equation $x + (-x) = 0$, and the fact that $x + (-x)$ could be written as $x + y[(-x)/y]$. We then used Proposition 5.1 on $x + y$. In order for this argument to work in general, we hence require:

- a term s' which is equal to a constant, $s' = x + (-x)$ in the example above.
- a term s'' such that s' is equal to s'' under a certain substitution, $s'' = x + y$ in the example.
- since we want to apply Proposition 5.1, s'' needs to satisfy the conditions for this proposition.

- and lastly we require that s' and s'' share at least one variable, which is a technicality needed to make the proof go through.

We need axiom (T2) to be able to apply Proposition 5.1. As a reminder, it reads: “If a variable substitution of term t' is provably equal to a constant, then t' is already provably equal to that constant.”

Proof. Let \mathbb{U} be any (candidate) composite theory of \mathbb{T} after \mathbb{S} . Consider the equation $s' = e_{\mathbb{S}}$. We know from axiom (S2) that \mathbb{S} has a term s such that $e_{\mathbb{S}}$ is a unit of s . Choose variable x such that $x \notin \text{var}(s')$. Then we use both the unit equation for s and the fact that $s' = e_{\mathbb{S}}$:

$$\begin{aligned} & x =_{\mathbb{U}} s[e_{\mathbb{S}}/y \neq x] \\ \Rightarrow & \{ e_{\mathbb{S}} =_{\mathbb{S}} s' \} \\ & x =_{\mathbb{U}} s[s'/y \neq x]. \end{aligned}$$

Next, we substitute $e_{\mathbb{T}}$ into all variables in s' . Since we chose x such that $x \notin \text{var}(s')$, this substitution has no effect on the left hand side of our equation.

$$\begin{aligned} & x =_{\mathbb{U}} s[s'/y \neq x] \\ \Rightarrow & \{ \text{substitution} \} \\ & x[e_{\mathbb{T}}/z \in \text{var}(s')] =_{\mathbb{U}} s[s'[e_{\mathbb{T}}/z \in \text{var}(s')]/y \neq x] \\ \Rightarrow & \{ x \notin \text{var}(s') \} \\ & x =_{\mathbb{U}} s[s'[e_{\mathbb{T}}/z \in \text{var}(s')]/y \neq x]. \end{aligned}$$

We will now work on the term $s[s'[e_{\mathbb{T}}/z \in \text{var}(s')]/y \neq x]$. Recall that s' can be written as $s''[s_i/x_i]$ and s'' satisfies the conditions for Proposition 5.1. Also, since $\text{var}(s'') \cap \text{var}(s') \neq \emptyset$, we know that the substitution $s'[e_{\mathbb{T}}/z \in \text{var}(s')] =_{\mathbb{U}} s''[s_i/x_i][e_{\mathbb{T}}/z \in \text{var}(s')]$ yields a term where at least one of the variables of s'' gets substituted with $e_{\mathbb{T}}$. Hence by Proposition 5.1, this resulting term is equal to $e_{\mathbb{T}}$. Therefore:

$$\begin{aligned} & x =_{\mathbb{U}} s[s'[e_{\mathbb{T}}/z \in \text{var}(s')]/y \neq x] \\ \Rightarrow & \{ \text{writing } s' \text{ as } s''[s_i/x_i] \} \\ & x =_{\mathbb{U}} s[s''[s_i/x_i][e_{\mathbb{T}}/z \in \text{var}(s')]/y \neq x] \\ \Rightarrow & \{ \text{Proposition 5.1: } s''[s_i/x_i][e_{\mathbb{T}}/z \in \text{var}(s')] =_{\mathbb{U}} e_{\mathbb{T}} \} \\ & x =_{\mathbb{U}} s[e_{\mathbb{T}}/y \neq x] \\ \Rightarrow & \{ \text{Proposition 5.1 again} \} \\ & x =_{\mathbb{U}} e_{\mathbb{T}}. \end{aligned}$$

Notice that in the last step, we applied Proposition 5.1 to s instead of s'' . We are allowed to do this because s is unital by assumption (S2), and hence also satisfies Proposition 5.1.

From the equation $x =_{\mathbb{U}} e_{\mathbb{T}}$, we get by simple variable substitution that $y =_{\mathbb{U}} e_{\mathbb{T}}$ for any variable y , and so specifically: $x =_{\mathbb{U}} e_{\mathbb{T}} =_{\mathbb{U}} y$. We conclude that \mathbb{U} is inconsistent. As the original theories are assumed to be consistent, there is no such composite theory. \square

Example 5.12. In case of Abelian groups and monoids, the equation $s' = e_{\mathbb{S}}$ required from Abelian groups is the inverse equation $x + (-x) = 0$. Equation $x + (-x)$ can be written as $(x + y)[(-x)/y]$. Since the terms $x + y$ and $x + (-x)$ share the variable x , condition (S3) is satisfied.

Example 5.13. There are countless monads satisfying the criteria for \mathbb{T} . A few natural examples are the list, multiset, powerset, and the exception monads.

We have already seen that Abelian groups satisfy the criteria for \mathbb{S} . In addition, any theory with a multiplicative zero $x * 0 = 0$ can be a good candidate, if the binary operation $*$ is either idempotent or unital. Rings are an obvious example, but Proposition 5.1 gives us many more. The multiset monad satisfies all the criteria for \mathbb{S} and \mathbb{T} in Proposition 5.1. We know that there is a distributive law for the multiset monad over itself, see Example 2.14, so the unit of one of the binary operations in the composite theory corresponding to the monad $M \circ M$ must act a multiplicative zero for the other.

We can hence make the following table of example compositions Theorem 5.10 proves impossible via a distributive law:

Table 5.2: Overview of some distributive laws of type:
row \circ column \Rightarrow column \circ row, which are excluded by Theorem 5.10.

	List	Multiset	Powerset	Exception
Abelian groups	\times	\times	\times	\times
Rings	\times	\times	\times	\times
(Multiset) ²	\times	\times	\times	\times

More examples illustrating the scope of Theorem 5.10 will be given in Chapter 6.

The second theorem we find as a generalisation of Counterexample 5.9 focusses on the equation $s = s'$, where s has a variable that does not appear in s' . Although this is a slightly less direct abstraction of Counterexample 5.9 than Theorem 5.10 is, it does exploit the same technique of controlled introduction and elimination of

variables. Here the motivating example axiom is the absorption law $x \vee (x \wedge y) = x$, seen in lattices and similar structures.

Theorem 5.14 (No-Go Theorem: Absorption Trouble). *Let \mathbb{S} be an algebraic theory such that:*

(S1) \mathbb{S} satisfies an equation of form $X \vdash s =_{\mathbb{S}} s'$, where $\text{var}(s) \setminus \text{var}(s') \neq \emptyset$ (that is, s has a variable that does not appear in s').

(S2) There is a substitution $f : \text{var}(s) \rightarrow \mathbb{S}$ such that for any $x \in \text{var}(s)$:

$$\Gamma \vdash s[f(y)/y \neq x] =_{\mathbb{S}} x.$$

(S3) There is a substitution $f' : \text{var}(s') \rightarrow \mathbb{S}$ such that for any $x \in \text{var}(s')$:

$$\Gamma \vdash s'[f'(y)/y \neq x] =_{\mathbb{S}} x.$$

Let \mathbb{T} be an algebraic theory such that:

(T1) \mathbb{T} has a constant $e_{\mathbb{T}}$.

(T2) For all terms t' and any substitution $f : X \rightarrow Y$:

$$Y \vdash t'[f] =_{\mathbb{T}} e_{\mathbb{T}} \quad \Rightarrow \quad X \vdash t' =_{\mathbb{T}} e_{\mathbb{T}}.$$

Then there does not exist a composite theory of \mathbb{T} after \mathbb{S} .

Remark 5.15 (Interpretation of Axioms). (S2) and (S3) are again generalisations of idempotence/unitality equations, needed to apply Proposition 5.1, and (T2) is the now familiar axiom stating “If a variable substitution of term t' is provably equal to a constant, then t' is already provably equal to that constant.”

Proof. Let \mathbb{U} be any (candidate) composite theory of \mathbb{T} after \mathbb{S} . Consider the equation $s = s'$ from the assumptions. Let f' be a substitution of the variables in s' such that $s'[f'] =_{\mathbb{S}} x$, where $x \in \text{var}(s')$. Then:

$$\begin{aligned} & s =_{\mathbb{S}} s' \\ \Rightarrow & \{ \text{axiom of substitution} \} \\ & s[f'] =_{\mathbb{S}} s'[f'] \\ \Rightarrow & \{ s'[f'] =_{\mathbb{S}} x \text{ by construction of } f' \} \\ & s[f'] =_{\mathbb{S}} x. \end{aligned}$$

Now let g be the constant substitution $g : \text{var}(s) \setminus \text{var}(s') \rightarrow \{e_{\top}\}$, mapping all the variables that appear in s but not in s' to the constant e_{\top} . Since $\text{var}(s) \setminus \text{var}(s') \neq \emptyset$, at least one instance of e_{\top} will be present in $s[f'][g]$. Then:

$$\begin{aligned}
& s[f'] =_{\mathbb{U}} x \\
\Rightarrow & \quad \{ \text{axiom of substitution} \} \\
& s[f'][g] =_{\mathbb{U}} x[g] \\
\Rightarrow & \quad \{ x \in \text{var}(s') \text{ and therefore untouched by } g \} \\
& s[f'][g] =_{\mathbb{U}} x \\
\Rightarrow & \quad \{ \text{Proposition 5.1, since } s[f'][g] \text{ contains at least one } e_{\top} \} \\
& e_{\top} =_{\mathbb{U}} x.
\end{aligned}$$

Using substitution, we can hence show that $x =_{\mathbb{U}} e_{\top} =_{\mathbb{U}} y$, from which it follows that \mathbb{U} is inconsistent. As the original theories are assumed to be consistent, there is no such composite theory. \square

Theorem 5.14 solves a question Julian Salamanca posed in 2018 [55], asking whether there is a distributive law $bL \circ P \Rightarrow P \circ bL$, distributing the bounded lattice monad bL over the powerset monad P . The answer is no.

Example 5.16. There is no distributive law for the (bounded) lattice monad over the powerset monad. The presentation for the bounded lattice monad is given by:

- Signature: $\{\top^{(0)}, \perp^{(0)}, \vee^{(2)}, \wedge^{(2)}\}$.
- Equations: \top is the unit of \wedge , \perp is the unit of \vee , associativity of \vee and \wedge , commutativity of \vee and \wedge , idempotence of \vee and \wedge , absorption both ways: $x \vee (x \wedge y) = x$ and $x \wedge (x \vee y) = x$.

We see that the bounded lattice monad satisfies the criteria for \mathbb{S} in Theorem 5.14:

- The equation $s = s'$ is $x \vee (x \wedge y) = x$.
- The substitution f such that $s[f] = x$ uses the unit of \wedge and idempotence of \vee :

$$x \vee (x \wedge y)[\top/y] = x \vee (x \wedge \top) = x \vee x = x.$$

- The substitution f' such that $s'[f'] = x$ is the identity, since the term s' is just the variable x .

The presentation of the powerset monad is given by:

- Signature: $\{0^{(0)}, +^{(2)}\}$.
- Equations: 0 is unit of $+$, $+$ is associative, commutative, and idempotent.

The powerset monad satisfies the criteria for \mathbb{T} in Theorem 5.14, and so we conclude that there is no distributive law $bL \circ P \Rightarrow P \circ bL$.

Remark 5.17. The proofs of the two theorems above use intricate variable manipulations to reach their goal. This is a common theme in theorems about distributive laws: the well-known positive result of Manes and Mulry requires monads presented by theories with only linear equations [44, Theorem 4.3.4]. That is, with variables appearing exactly once on each side of the equation. These monads distribute over commutative monads in the direction $\text{linear} \circ \text{commutative} \Rightarrow \text{commutative} \circ \text{linear}$. Linear equations have the advantage that their variables are easy to manage and analyse, since variables can neither be duplicated nor be deleted. Similarly strict variable management properties will prove to be essential for some of our later no-go theorems, for instance those in Section 5.3.

In this regard, the inverse and absorption equations from this section are ‘wildly behaving’ equations, since they can make any variable appear or disappear. This makes it impossible to keep a tight bound on the variables that can appear in the terms we analyse in the proofs. But rather than seeing this behaviour as a nuisance, the theorems in this section use it to their advantage. The ability to make new variables appear means that we can introduce variables on one side of an equation but not the other, and hence we can define substitutions that affect only one side of an equation.

5.3 No-Go Theorems Based on Idempotence

In the previous section we gained two general no-go theorems by analysing a specific counterexample, namely the impossibility of ‘plus’ (the Abelian group monad A) to distribute over ‘times’ (the list monad L). In this section, we will again produce a class of no-go theorems based on the analysis of one specific counterexample. The counterexample central to this section was found by Plotkin [60], and proves that there is no distributive law for the distribution monad over the powerset monad: $DP \Rightarrow PD$.

Plotkin’s counterexample was originally presented categorically, so our first efforts will focus on translating its proof into our algebraic setting. This translation will make it easier to keep track of the assumptions that are being made in the proof, which will then lead us to our first general no-go theorem: Theorem 5.20. We then set out to generalise this theorem even further, resulting in Theorems 5.25, 5.28, and 5.30.

5.3.1 The Original Counterexample

We present Plotkin’s original counterexample [60], slightly rephrased to facilitate a translation from the categorical proof into our algebraic framework, and annotated with comments to explain the strategies that are used.

Counterexample 5.18. There is no distributive law of type $D \circ P \Rightarrow P \circ D$, where D is the finite probability distribution monad and P the finite powerset monad.

Remark 5.19. The original counterexample involves the free real cone monad (a.k.a. the finite valuation monad) instead of the finite probability distribution monad, because it requires slightly weaker assumptions. Since we are generalising the algebraic properties later on, we choose to restrict to the simpler probability distribution monad for now. Our later results are equally applicable to the free real cone monad.

Proof. Assume, by way of a contradiction, that there is a distributive law $\lambda : D \circ P \Rightarrow P \circ D$. Fix the set $X = \{a, b, c, d\}$, and consider the element $\Xi \in DP(X)$ defined as:

$$\Xi = \{a, b\} + \frac{1}{2} \{c, d\}.$$

We define three functions $f_1, f_2, f_3 : X \rightarrow X$:

$$\begin{array}{lll} f_1(a) = a & f_2(a) = a & f_3(a) = a \\ f_1(b) = b & f_2(b) = b & f_3(b) = a \\ f_1(c) = a & f_2(c) = b & f_3(c) = b \\ f_1(d) = b & f_2(d) = a & f_3(d) = b \end{array}$$

The plan of the proof is to analyse how Ξ travels around the naturality square for λ , for each of the three functions. The element Ξ and the three functions have been carefully chosen so that the distributive law unit axioms can be applied during the proof.

$$\begin{array}{ccc} DP(X) & \xrightarrow{\lambda_X} & PD(X) \\ DP(f_i) \downarrow & & \downarrow PD(f_i) \\ DP(X) & \xrightarrow{\lambda_X} & PD(X) \end{array} \quad (5.1)$$

We first trace Ξ around the naturality square (5.1) for f_1 . Since $+\frac{1}{2}$ is idempotent, we conclude:

$$\begin{aligned} DP(f_1)(\Xi) &= \{a, b\} + \frac{1}{2} \{a, b\} \\ &= \eta_{PX}^D \{a, b\}. \end{aligned}$$

We then apply the first distributive law unit axiom to conclude that:

$$\lambda_X \circ DP(f_1)(\Xi) = \{\eta_X^D(a), \eta_X^D(b)\}.$$

Now we consider the action of $PD(f_1)$, effectively reversing the right vertical arrow in the naturality square, by computing the preimage of f_1 : $f_1^{-1}(a) = \{a, c\}$, $f_1^{-1}(b) = \{b, d\}$. We conclude that any element in $\lambda(\Xi)$ that is mapped by $PD(f_1)$ to $\eta_X^D(a)$ can only contain the variables a and c , and any element that is mapped to $\eta_X^D(b)$ can only contain the variables b and d . Therefore, $\lambda_X(\Xi)$ must be a subset of:

$$\{a +^p c \mid p \in [0, 1]\} \cup \{b +^p d \mid p \in [0, 1]\}.$$

Next, we trace Ξ around the naturality square (5.1) for f_2 . We use commutativity of $\{-, -\}$ and idempotence of $+\frac{1}{2}$ to conclude:

$$\begin{aligned} DP(f_2)(\Xi) &= \{a, b\} + \frac{1}{2} \{b, a\} \\ &= \{a, b\} + \frac{1}{2} \{a, b\} \\ &= \eta_{PX}^D \{a, b\}. \end{aligned}$$

We then apply the first distributive law unit axiom again to conclude that:

$$\lambda_X \circ DP(f_2)(\Xi) = \{\eta_X^D(a), \eta_X^D(b)\}.$$

And again, we reverse the right vertical arrow in the naturality square by computing the preimage of f_2 : $f_2^{-1}(a) = \{a, d\}$, and $f_2^{-1}(b) = \{b, c\}$. We conclude that any element in $\lambda(\Xi)$ that is mapped by $PD(f_2)$ to $\eta_X^D(a)$ can only contain the variables a and d , and any element that is mapped to $\eta_X^D(b)$ can only contain the variables b and c . Therefore, $\lambda_X(\Xi)$ must be a subset of:

$$\{a +^p d \mid p \in [0, 1]\} \cup \{b +^p c \mid p \in [0, 1]\}.$$

This, together with our conclusion from tracing Ξ around the naturality square for f_1 , yields that $\lambda_X(\Xi)$ must be a subset of:

$$\{\eta_X^D(a), \eta_X^D(b), \eta_X^D(c), \eta_X^D(d)\}.$$

Lastly, we trace Ξ around the naturality square (5.1) for f_3 . In this case, we exploit the idempotence of the operation $\{-, -\}$ to conclude:

$$\begin{aligned} DP(f_3)(\Xi) &= \{a, a\} + \frac{1}{2} \{b, b\} \\ &= \eta_X^P(a) + \frac{1}{2} \eta_X^P(b). \end{aligned}$$

This time, we apply the second unit axiom for λ to conclude:

$$\lambda_X \circ DP(f_3)(\Xi) = \eta_{DX}^P(a + \frac{1}{2} b).$$

By considering the action of $PD(f_3)$ as before, we conclude that $\lambda_X(\Xi)$ must contain an element mapped onto $a + \frac{1}{2} b$ by $PD(f_3)$. That means that $\lambda_X(\Xi)$ must contain an element with at least two variables. However, we previously concluded that $\lambda_X(\Xi)$ must be a subset of $\{\eta_X^D(a), \eta_X^D(b), \eta_X^D(c), \eta_X^D(d)\}$, and none of these elements contain more than one variable. Contradiction, hence no distributive law of type $D \circ P \Rightarrow P \circ D$ can exist. \square

In summary, the proof considers the unknown action of a possible distributive law λ on the element Ξ . By chasing the naturality square for two different functions, it establishes an *upper bound* on the number of variables that can appear in each element of $\lambda_X(\Xi)$: each element in $\lambda_X(\Xi)$ can have at most one variable. Then, a third naturality square is used to establish a *lower bound* on the number of variables: $\lambda_X(\Xi)$ must contain an element with at least two variables. The upper and lower bounds contradict each other, which means such a distributive law cannot exist.

5.3.2 Generalising Plotkin's Counterexample

Some of the arguments used in the proof above clearly allude to algebraic properties, such as idempotence and commutativity. This strongly suggests that our algebraic framework is well-suited for analysing and generalising this example. Some other parts of the argument, however, are less straightforward to pin down. An essential part of the proof involves 'taking an inverse image' to reason about variables that may appear in as yet unknown elements. In principle this reasoning involves inverse images of equivalence classes of terms in one algebraic theory, with variables labelled by equivalence classes of terms in a second algebraic theory. It is not immediately obvious why this argument works for the powerset and distribution monads and not for other monads. This strongly motivates our move to an algebraic setting, where we can reason on terms directly, without equivalence classes obscuring any details and making things unnecessarily complicated.

We start by making a direct algebraic translation of the argument presented in Counterexample 5.18. This will reveal precisely which algebraic properties are used in the proof. In doing so, we produce our first general no-go theorem based on this counterexample. We then further generalise by considering which of the algebraic properties we used can be relaxed, without breaking the proof.

Some of the properties required in the following theorem may look unfamiliar; these are the ones required to make the ‘inverse image’ part of the proof work. They are explained in more detail in Remark 5.21 below.

Theorem 5.20. *Let \mathbb{S} and \mathbb{T} be two algebraic theories. If there are terms:*

$$2 \vdash_{\mathbb{S}} s \quad \text{and} \quad 2 \vdash_{\mathbb{T}} t,$$

such that:

(S1) *s is idempotent:*

$$\{a\} \vdash s(a, a) =_{\mathbb{S}} a.$$

(S2) *For all terms $s' \in \mathbb{S}$, and any variable a:*

$$\Gamma \vdash a =_{\mathbb{S}} s' \quad \Rightarrow \quad \{a\} \vdash s'.$$

(S3) *For all terms $s' \in \mathbb{S}$:*

$$\Gamma \vdash s(a, b) =_{\mathbb{S}} s' \quad \Rightarrow \quad \neg(\{a\} \vdash s' \vee \{b\} \vdash s').$$

(T1) *t is commutative:*

$$\{a, b\} \vdash t(a, b) =_{\mathbb{T}} t(b, a).$$

(T2) *t is idempotent:*

$$\{a\} \vdash t(a, a) =_{\mathbb{T}} a.$$

(T3) *For all terms $t' \in \mathbb{T}$:*

$$\Gamma \vdash t(a, b) =_{\mathbb{T}} t' \quad \Rightarrow \quad \{a, b\} \vdash t'.$$

Then there is no composite theory of \mathbb{T} after \mathbb{S} .

Remark 5.21. Properties (T3), (S2), and (S3) are constraints on the variables appearing in certain terms, which are needed for the ‘inverse image’ part of Counterexample 5.18. Property (T3) states that any term equal to the special binary term t can have at most two free variables. Property (S2) states that any term equal to a variable can only contain that variable, and property (S3) states that any term equal to the special binary term s must have at least two free variables. Notice that the upper/lower bound principle from the original argument is reflected in these conditions.

Proof. Assume by way of a contradiction that a composite theory \mathbb{U} of \mathbb{T} after \mathbb{S} exists. Consider the term:

$$s(t(a, b), t(c, d)).$$

Then as \mathbb{U} is composite and $s(t(a, b), t(c, d))$ is not a separated term, the separation axiom of composite theories says that there exist $X \vdash t'$ and $\Gamma \vdash s'_x$ for each $x \in X$ such that:

$$s(t(a, b), t(c, d)) =_{\mathbb{U}} t'[s'_x/x]. \quad (5.2)$$

As in Counterexample 5.18, we use three substitutions: two to establish an upper bound on variables appearing in certain terms, and one to establish a contradicting lower bound. Define the first substitution f_1 as follows:

$$\begin{aligned} f_1(a) &= a \\ f_1(b) &= b \\ f_1(c) &= a \\ f_1(d) &= b \end{aligned}$$

Then, using this substitution of variables and assumption (S1):

$$\begin{aligned} & s(t(a, b), t(c, d)) =_{\mathbb{U}} t'[s'_x/x] \\ \Rightarrow & \{ \text{axiom of substitution} \} \\ & s(t(a, b), t(c, d))[f_1] =_{\mathbb{U}} t'[s'_x[f_1]/x] \\ \Rightarrow & \{ \text{applying the substitution on the left hand side} \} \\ & s(t(a, b), t(a, b)) =_{\mathbb{U}} t'[s'_x[f_1]/x] \\ \Rightarrow & \{ \text{assumption (S1): } s \text{ is idempotent} \} \\ & t(a, b) =_{\mathbb{U}} t'[s'_x[f_1]/x]. \end{aligned}$$

We now have two separated terms that are equal to each other, so we can apply essential uniqueness. This gives us that there are functions $g_1 : \{a, b\} \rightarrow Z$ and $g_2 : X \rightarrow Z$ such that:

$$t[g_1] =_{\mathbb{T}} t'[g_2] \quad (\text{Proposition 3.4, 3a})$$

$$g_1(a) \neq g_1(b) \quad (\text{Proposition 3.4, 3b})$$

$$g_1(a) = g_2(x) \Leftrightarrow a =_{\mathbb{S}} s'_x[f_1] \quad (\text{Proposition 3.4, 3d})$$

$$g_1(b) = g_2(x) \Leftrightarrow b =_{\mathbb{S}} s'_x[f_1]. \quad (\text{Proposition 3.4, 3d})$$

By assumption (T3) we must have for all $x \in \text{var}(t')$: $g_2(x) = g_1(a)$ or $g_2(x) = g_1(b)$, which means for each s'_x :

$$s'_x[f_1] =_{\mathbb{S}} a \quad \text{or} \quad s'_x[f_1] =_{\mathbb{S}} b.$$

Then using assumption (S2) and the preimage of f_1 , we conclude that for all s'_x :

$$\{a, c\} \vdash s'_x \quad \text{or} \quad \{b, d\} \vdash s'_x. \quad (5.3)$$

We use the same strategy again with our second substitution f_2 , which is defined as follows:

$$f_2(a) = a$$

$$f_2(b) = b$$

$$f_2(c) = b$$

$$f_2(d) = a$$

Using this substitution and assumptions (T1) and (S1):

$$\begin{aligned} & s(t(a, b), t(c, d)) =_{\mathbb{U}} t'[s'_x/x] \\ \Rightarrow & \{ \text{axiom of substitution} \} \\ & s(t(a, b), t(c, d))[f_2] =_{\mathbb{U}} t'[s'_x[f_2]/x] \\ \Rightarrow & \{ \text{applying the substitution on the left hand side} \} \\ & s(t(a, b), t(b, a)) =_{\mathbb{U}} t'[s'_x[f_2]/x] \\ \Rightarrow & \{ \text{assumption (T1): } t \text{ is commutative} \} \\ & s(t(a, b), t(a, b)) =_{\mathbb{U}} t'[s'_x[f_2]/x] \\ \Rightarrow & \{ \text{assumption (S1): } s \text{ is idempotent} \} \\ & t(a, b) =_{\mathbb{U}} t'[s'_x[f_2]/x]. \end{aligned}$$

Again we have two separated terms that are equal, so we apply essential uniqueness. This gives us that there are functions $g_3 : \{a, b\} \rightarrow Z$ and $g_4 : X \rightarrow Z$ such that:

$$\begin{aligned}
t[g_3] &=_{\mathbb{T}} t'[g_4] && \text{(Proposition 3.4, 3a)} \\
g_3(a) &\neq g_3(b) && \text{(Proposition 3.4, 3b)} \\
g_3(a) = g_4(x) &\Leftrightarrow a =_{\mathbb{S}} s'_x[f_2] && \text{(Proposition 3.4, 3d)} \\
g_3(b) = g_4(x) &\Leftrightarrow 2 =_{\mathbb{S}} s'_x[f_2]. && \text{(Proposition 3.4, 3d)}
\end{aligned}$$

By assumption (T3) we must have for all $x \in \text{var}(t')$: $g_4(x) = g_3(a)$ or $g_4(x) = g_3(b)$, which means for each s'_x :

$$s'_x[f_2] =_{\mathbb{S}} a \quad \text{or} \quad s'_x[f_2] =_{\mathbb{S}} b.$$

and so, using assumption (S2) and the preimage of f_2 , we know that for all s'_x :

$$\{a, d\} \vdash s'_x \quad \text{or} \quad \{b, c\} \vdash s'_x. \quad (5.4)$$

We combine the two conclusions (5.3) and (5.4), yielding that for all s'_x :

$$\begin{aligned}
&(\{a, c\} \vdash s'_x \vee \{b, d\} \vdash s'_x) \wedge (\{a, d\} \vdash s'_x \vee \{b, c\} \vdash s'_x) \\
\Rightarrow &\{ \text{distributing } \wedge \text{ over } \vee \} \\
&(\{a, c\} \vdash s'_x \wedge \{a, d\} \vdash s'_x) \vee (\{a, c\} \vdash s'_x \wedge \{b, c\} \vdash s'_x) \vee \\
&(\{b, d\} \vdash s'_x \wedge \{a, d\} \vdash s'_x) \vee (\{b, d\} \vdash s'_x \wedge \{b, c\} \vdash s'_x) \\
\Rightarrow &\{ \text{this is only possible if } \} && (5.5)
\end{aligned}$$

$$\{a\} \vdash s'_x \vee \{c\} \vdash s'_x \vee \{d\} \vdash s'_x \vee \{b\} \vdash s'_x. \quad (5.6)$$

In other words, each s'_x can have at most one variable.

To get a contradiction, we will now find an s'_x that must have at least two variables. This is where we need assumption (S3). We make one more substitution. Define f_3 as follows:

$$\begin{aligned}
f_3(a) &= a \\
f_3(b) &= a \\
f_3(c) &= b \\
f_3(d) &= b
\end{aligned}$$

Using this final substitution and (T2):

$$\begin{aligned}
& s(t(a, b), t(c, d)) =_{\mathbb{U}} t'[s'_x/x] \\
\Rightarrow & \{ \text{axiom of substitution} \} \\
& s(t(a, b), t(c, d))[f_3] =_{\mathbb{U}} t'[s'_x[f_3]/x] \\
\Rightarrow & \{ \text{applying the substitution on the left hand side} \} \\
& s(t(a, a), t(b, b)) =_{\mathbb{U}} t'[s'_x[f_3]/x] \\
\Rightarrow & \{ \text{assumption (T2): } t \text{ is idempotent} \} \\
& s(a, b) =_{\mathbb{U}} t'[s'_x[f_3]/x] \\
\Rightarrow & \{ \text{making it more obvious that } s(a, b) \text{ is a separated term} \} \\
& y[s(a, b)/y] =_{\mathbb{U}} t'[s'_x[f_3]/x].
\end{aligned}$$

Again, we arrive at an equality between two separated terms, allowing us to apply essential uniqueness. This gives us that there are functions $g_5 : \{y\} \rightarrow Z$ and $g_6 : X \rightarrow Z$ such that:

$$y[g_5] =_{\mathbb{T}} t'[g_6] \quad (\text{Proposition 3.4, 3a})$$

$$g_5(y) = g_6(x) \Leftrightarrow s(a, b) =_{\mathbb{S}} s'_x[f_3]. \quad (\text{Proposition 3.4, 3d})$$

By consistency of \mathbb{T} , the variable $g_5(y)$ appears in $t'[g_6]$. If it did not, we could define a substitution h mapping $g_5(y)$ to any other variable z , and then conclude $z =_{\mathbb{T}} g_5(y)[h] =_{\mathbb{T}} t'[g_6][h] =_{\mathbb{T}} t'[g_6] =_{\mathbb{T}} g_5(y)$, which proves all variables are equal to each other in \mathbb{T} , which means \mathbb{T} is inconsistent. So we know that the variable $g_5(y)$ must appear in $t'[g_6]$. Hence, there is an x_0 such that $g_5(y) = g_6(x_0)$. And so:

$$s(a, b) =_{\mathbb{S}} s'_{x_0}[f_3].$$

By (S3), $s'_{x_0}[f_3]$ must have at least two variables. Which means s'_{x_0} must have at least two variables. This contradicts Equation (5.6), which claims that each s'_x can have at most one variable. Therefore the assumed composite theory cannot exist. \square

Example 5.22 (Powerset and Distribution Monad). Consider the terms $a * b$ and $a + \frac{1}{2} b$ in the theories representing the powerset and distribution monads of Example 2.32. Since both of these terms are binary, commutative, and idempotent, and the remaining axioms are satisfied, Theorem 5.20 captures the known results that there are no distributive laws of type $D \circ P \Rightarrow P \circ D$ [60], $P \circ P \Rightarrow P \circ P$ [35], or $P \circ D \Rightarrow D \circ P$ [61, stated without proof]. In addition, Theorem 5.20 yields the new result that there is no distributive law of type $D \circ D \Rightarrow D \circ D$, completing the picture for these monads. These results are summarised in the table below:

	P	D
P	\times	\times
D	\times	\times

Non-Example 5.23 (Reader Monad). It is well known that the reader monad distributes over itself. Looking at the presentation of the reader monad given in Example 2.32, we see that although it has idempotent terms, there is no commutative term and hence Theorem 5.20 does not apply.

A natural question to ask with regard to Theorem 5.20 is whether the choice of *binary* terms for both s and t is necessary. We thank Prakash Panangaden for posing this question during an informal presentation of this work [50]. The answer is that we can generalise to terms with any arities strictly greater than one. Before we prove this more general statement, we introduce a lemma that will help to establish the upper bound part of the argument.

Lemma 5.24. *Let n, m be strictly positive natural numbers, and σ a fixed-point free permutation of $\{1, \dots, m\}$. For distinct variables a_i^j , $1 \leq i \leq m$, $1 \leq j \leq n$, the sets:*

$$\begin{aligned} &\{a_{i_1}^1, a_{i_1}^2, a_{i_1}^3, \dots, a_{i_1}^n\} \\ &\{a_{i_2}^1, a_{\sigma(i_2)}^2, a_{i_2}^3, \dots, a_{i_2}^n\} \\ &\quad \vdots \\ &\{a_{i_n}^1, a_{i_n}^2, a_{i_n}^3, \dots, a_{\sigma(i_n)}^n\} \end{aligned}$$

have at most one common element. Here, each i_k is an element of $\{i \mid 1 \leq i \leq m\}$, not necessarily unique.

Proof. We proceed by induction on n . The base case $n = 1$ is trivially true. For $n = n' + 1$, we consider the first two rows of our table of sets. There are two cases.

1. If $i_1 = \sigma(i_2)$, then the first two rows can only agree at their second element, because each a_i^j is distinct, and from the assumption that σ is fixed-point free we know that i_1 is different from i_2 if $\sigma(i_2) = i_1$. The claim follows directly from this observation.
2. If $i_1 \neq \sigma(i_2)$ then the first two rows disagree in the second column. Therefore the elements common to all the sets cannot appear in the second column. We then remove both row and column 2, and invoke the induction hypothesis for $n = n'$.

□

We then get a more general variant of Theorem 5.20.

Theorem 5.25. *Let \mathbb{S} and \mathbb{T} be two algebraic theories. If there are terms:*

$$n \vdash_{\mathbb{S}} s \quad \text{and} \quad m \vdash_{\mathbb{T}} t,$$

such that:

(S4) *s is idempotent:*

$$\{a\} \vdash s[a/x_i] =_{\mathbb{S}} a.$$

(S5) *For all terms $s' \in \mathbb{S}$, and any variable a :*

$$\Gamma \vdash a =_{\mathbb{S}} s' \quad \Rightarrow \quad \{a\} \vdash s'.$$

(S6) *For all terms $s' \in \mathbb{S}$:*

$$\Gamma \vdash s =_{\mathbb{S}} s' \quad \Rightarrow \quad \neg \left(\bigvee_{x_i \in \Gamma} \{x_i\} \vdash s' \right).$$

(T4) *t is stable under a fixed-point free permutation σ :*

$$m \vdash t =_{\mathbb{T}} t[\sigma(x)/x].$$

(T5) *t is idempotent:*

$$\{a\} \vdash t[a/x_i] =_{\mathbb{T}} a.$$

(T6) *For all terms $t' \in \mathbb{T}$:*

$$\Gamma \vdash t =_{\mathbb{T}} t' \quad \Rightarrow \quad m \vdash t'.$$

Then there is no composite theory of \mathbb{T} after \mathbb{S} .

Remark 5.26. The required properties are generalisations of the binary conditions in Theorem 5.20. Most are straightforward, but axiom (T4), the analogue of binary commutativity, is perhaps slightly surprising. Here we only require stability under a single fixed-point free permutation.

Proof. Assume by way of a contradiction that a composite theory \mathbb{U} of \mathbb{T} after \mathbb{S} exists. Let a_i^j denote distinct variables, where $1 \leq i \leq m$ and $1 \leq j \leq n$. We consider the term

$$s(t(a_1^1, \dots, a_m^1), \dots, t(a_1^n, \dots, a_m^n)).$$

Then as \mathbb{U} is composite, the separation axiom of composite theories tells us that there exist $X \vdash t'$ and $\Gamma \vdash s'_x$ for each $x \in X$ such that:

$$s(t(a_1^1, \dots, a_m^1), \dots, t(a_1^n, \dots, a_m^n)) =_{\mathbb{U}} t'[s'_x/x].$$

We use the same approach as in the proof of Theorem 5.20, using substitutions to bound the variables that can appear in each of the s'_x . Define substitution f_1 as follows:

$$f_1(a_i^j) = a_i^1.$$

We then have:

$$s(t(a_1^1, \dots, a_m^1), \dots, t(a_1^1, \dots, a_m^1)) =_{\mathbb{U}} t'[s'_x[f_1]/x].$$

By assumption (S4), idempotence of s :

$$t(a_1^1, \dots, a_m^1) =_{\mathbb{U}} t'[s'_x[f_1]/x].$$

We have two separated terms that are equal to each other, so essential uniqueness tells us that there are substitutions g_1 and g_2 such that:

$$t[g_1] =_{\mathbb{T}} t'[g_2] \quad (\text{Proposition 3.4, 3a})$$

$$g_1(a_i^1) \neq g_1(a_j^1) (i \neq j) \quad (\text{Proposition 3.4, 3b})$$

$$g_1(a_i^1) = g_2(x) \Leftrightarrow a_i^1 =_{\mathbb{S}} s'_x[f_1], \quad (\text{Proposition 3.4, 3d})$$

and (T6) gives us that:

$$\forall x \exists i : a_i^1 =_{\mathbb{S}} s'_x[f_1].$$

Then by assumption (S5):

$$\forall x \exists i : \{a_i^1\} \vdash s'_x[f_1].$$

So our first approximation of the variables appearing in s'_x is:

$$\forall x \exists i : \{a_i^1, \dots, a_i^n\} \vdash s'_x. \quad (5.7)$$

Now we define a family of substitutions for $2 \leq k \leq n$ as follows:

$$f_k(a_i^j) = \begin{cases} a_{\sigma(i)}^k & \text{if } j = k \\ a_i^k & \text{otherwise.} \end{cases}$$

If we follow a similar argument as before, using essential uniqueness, (T6), (S5), and also exploiting assumption (T4), we conclude that:

$$\forall x, k \exists i_k : \{a_{i_k}^k\} \vdash s'_x[f_k].$$

And so:

$$\forall x, k \exists i_k : \{a_{\sigma^{-1}(i_k)}^j \mid j = k\} \cup \{a_{i_k}^j \mid j \neq k\} \vdash s'_x. \quad (5.8)$$

Then we note that by Lemma 5.24, conditions (5.7) and (5.8):

$$\forall x \exists i, j : \{a_i^j\} \vdash s'_x. \quad (5.9)$$

This provides an upper bound on the number of variables appearing in the s'_x , just like the first two substitutions did in the proof of Theorem 5.20. To finish the argument, we define another substitution:

$$f_{n+1}(a_i^j) = a_1^j.$$

Applying this substitution:

$$s(t(a_1^1, \dots, a_1^1), \dots, t(a_1^n, \dots, a_1^n)) =_{\mathbb{U}} t'[s'_x[f_{n+1}]/x].$$

Using assumption (T5):

$$s(a_1^1, \dots, a_1^n) =_{\mathbb{U}} t'[s'_x[f_{n+1}]/x].$$

By essential uniqueness and consistency:

$$\exists x_0 : s(a_1^1, \dots, a_1^n) =_{\mathbb{S}} s'_{x_0}[f_{n+1}].$$

Then by assumption (S6), s'_{x_0} must contain at least two variables, but this contradicts conclusion (5.9), and so the assumed composite theory cannot exist. \square

It is clear that the simpler Theorem 5.20 is a special case of Theorem 5.25. Besides providing greater generality, the main point of Theorem 5.25 is that it clearly demonstrates that there is nothing special about binary terms. This further clarifies our understanding of what abstract properties make the original counterexample of Plotkin work.

5.3.3 Regarding Idempotency

All theorems so far rely heavily on idempotent terms in both theories. The main advantage idempotent terms provide for our proofs is that they can be reduced to a variable in a controlled way. Idempotency is, however, not the only algebraic property with this effect. Compare idempotency:

$$x * x = x$$

to unitality:

$$x * 1 = x.$$

Both idempotency and unitality have x as the only variable appearing on either side of the equation, and both equations reduce a more complicated term to a single variable.

In Section 5.2 we used a property that was slightly more general, namely: “term s has a substitution f such that for any variable $x \in \text{var}(s)$, $s[f(x')/x' \neq x] = x$ ”. We will use this generalisation of idempotency and unitality once more, leading to Theorem 5.28. The proof technique used for Theorem 5.20 still works with this more general assumption, although extra care needs to be taken when substituting a \mathbb{T} -term into an \mathbb{S} -term, as this could turn a previously separated term into a term that is no longer separated. As in the previous proofs, we need extra assumptions such as commutativity to make the proof go through. Notice that we only generalise one of the two idempotent terms. For the other term, the current proof method requires the more specific properties of idempotency.

Remark 5.27. In Theorem 5.28 below we state and prove the theorem for *binary* terms. This is to make it easier to see where and how the more general assumption replaces the assumption of idempotency in the proof. By copying the strategy from Theorem 5.25, however, it is straightforward to generalise Theorem 5.28 to the case where s is an n -ary term and t and m -ary term. The more general proof can be found in the appendix, Theorem B.1.

Theorem 5.28. *Let \mathbb{S} and \mathbb{T} be two algebraic theories. If there are terms:*

$$2 \vdash_{\mathbb{S}} s \quad \text{and} \quad 2 \vdash_{\mathbb{T}} t,$$

such that:

(S1) *s is idempotent:*

$$\{a\} \vdash s(a, a) =_{\mathbb{S}} a.$$

(S2) *For all terms $s' \in \mathbb{S}$, and each variable a :*

$$\Gamma \vdash a =_{\mathbb{S}} s' \quad \Rightarrow \quad \{a\} \vdash s'.$$

(S3) *For all terms $s' \in \mathbb{S}$:*

$$\Gamma \vdash s(a, b) =_{\mathbb{S}} s' \quad \Rightarrow \quad \neg(\{a\} \vdash s' \vee \{b\} \vdash s').$$

(T1) t is commutative:

$$\{a, b\} \vdash t(a, b) =_{\mathbb{T}} t(b, a).$$

(T2)' t has a substitution $f_t : \text{var}(t) \rightarrow \mathbb{T}$ such that:

$$\Gamma \vdash t(a, f_t(b)) =_{\mathbb{T}} a.$$

(T3) For all terms $t' \in \mathbb{T}$:

$$\Gamma \vdash t(a, b) =_{\mathbb{T}} t' \quad \Rightarrow \quad \{a, b\} \vdash t'.$$

Then there is no composite theory of \mathbb{T} after \mathbb{S} .

Proof. Assume by way of a contradiction that a composite theory \mathbb{U} of \mathbb{T} after \mathbb{S} exists. Then as \mathbb{U} is composite, the separation axiom tells us that there exist $X \vdash t'$ and $\Gamma \vdash s'_x$ for each $x \in X$ such that:

$$s(t(a, b), t(c, d)) =_{\mathbb{U}} t'[s'_x/x]. \quad (5.10)$$

We make the following substitution of variables:

$$\begin{aligned} f_1(a) &= a \\ f_1(b) &= b \\ f_1(c) &= a \\ f_1(d) &= b \end{aligned}$$

This yields:

$$\begin{aligned} s(t(a, b), t(a, b)) &=_{\mathbb{U}} t'[s'_x[f_1]/x] \\ \Leftrightarrow \quad \{s \text{ is idempotent}\} \\ t(a, b) &=_{\mathbb{U}} t'[s'_x[f_1]/x]. \end{aligned}$$

By essential uniqueness and assumption (T3), we conclude that for all x :

$$s'_x[f_1] =_{\mathbb{S}} a \quad \text{or} \quad s'_x[f_1] =_{\mathbb{S}} b. \quad (5.11)$$

So, using assumption (S2):

$$\{a, c\} \vdash s'_x \quad \text{or} \quad \{b, d\} \vdash s'_x. \quad (5.12)$$

We make a second substitution:

$$\begin{aligned} f_2(a) &= a \\ f_2(b) &= b \\ f_2(c) &= b \\ f_2(d) &= a \end{aligned}$$

This yields:

$$\begin{aligned} s(t(a, b), t(b, a)) &=_{\mathbb{U}} t'[s'_x[f_2]/x] \\ \Leftrightarrow \{ t \text{ is commutative} \} \\ s(t(a, b), t(a, b)) &=_{\mathbb{U}} t'[s'_x[f_2]/x] \\ \Leftrightarrow \{ s \text{ is idempotent} \} \\ t(a, b) &=_{\mathbb{U}} t'[s'_x[f_2]/x]. \end{aligned}$$

By essential uniqueness and assumption (T3), we conclude that for all x :

$$s'_x[f_2] =_{\mathbb{S}} a \quad \text{or} \quad s'_x[f_2] =_{\mathbb{S}} b.$$

So, using assumption (S2):

$$\{a, d\} \vdash s'_x \quad \text{or} \quad \{b, c\} \vdash s'_x. \quad (5.13)$$

Taking Equations (5.12) and (5.13) together, we conclude for all x , s'_x can only contain a single variable:

$$\{a\} \vdash s'_x \quad \vee \quad \{b\} \vdash s'_x \quad \vee \quad \{c\} \vdash s'_x \quad \vee \quad \{d\} \vdash s'_x.$$

This implies that for each x , s'_x is equal to a variable:

- If $\{a\} \vdash s'_x$, then $s'_x[f_1] = s'_x$. From Equation 5.11 we know that $s'_x[f_1] =_{\mathbb{S}} a$ or $s'_x[f_1] =_{\mathbb{S}} b$. And so also $s'_x =_{\mathbb{S}} a$ or $s'_x =_{\mathbb{S}} b$.
- If $\{b\} \vdash s'_x$, then also $s'_x[f_1] = s'_x$, and so again $s'_x =_{\mathbb{S}} a$ or $s'_x =_{\mathbb{S}} b$.
- If $\{c\} \vdash s'_x$, then $s'_x[f_1][c/a, d/b] = s'_x$. From Equation 5.11 we know that $s'_x[f_1][c/a, d/b] =_{\mathbb{S}} c$ or $s'_x[f_1][c/a, d/b] =_{\mathbb{S}} d$. And so also $s'_x =_{\mathbb{S}} c$ or $s'_x =_{\mathbb{S}} d$.
- If $\{d\} \vdash s'_x$, then also $s'_x[f_1][c/a, d/b] = s'_x$, and so again $s'_x =_{\mathbb{S}} c$ or $s'_x =_{\mathbb{S}} d$.

We make a final substitution, using the substitution f_t from property (T2)′:

$$\begin{aligned} f_3(a) &= a \\ f_3(b) &= f_t(b) \\ f_3(c) &= c \\ f_3(d) &= f_t(d) \end{aligned}$$

This yields:

$$\begin{aligned} & s(t(a, f_t(b)), t(c, f_t(d))) =_{\mathbb{U}} t'[s'_x[f_3]/x] \\ \Rightarrow & \{ \text{property (T2)'} \} \\ & s(a, c) =_{\mathbb{U}} t'[s'_x[f_3]/x] \\ \Rightarrow & \{ \text{clarifying that } s(a, c) \text{ is a separated term} \} \\ & y[s(a, c)/y] =_{\mathbb{U}} t'[s'_x[f_3]/x]. \end{aligned}$$

Notice that the term $t'[s'_x[f_3]/x]$ is still separated: since every s'_x is just a variable, the substitution f_3 does not break separation, even though it might insert a \mathbb{T} term. We apply essential uniqueness: there are substitutions $g_1 : \{y\} \rightarrow Z, g_2 : X \rightarrow Z$ such that:

$$\begin{aligned} y[g_1] &=_{\mathbb{T}} t'[g_2] \\ g_1(y) = g_2(x) &\Leftrightarrow s(a, c) =_{\mathbb{S}} s'_x. \end{aligned}$$

By consistency of \mathbb{T} , we know that there is at least one x such that $g_1(y) = g_2(x)$. And hence there is at least one s'_x such that $s'_x =_{\mathbb{S}} s(a, c)$. But this contradicts assumption (S3), since for all x , s'_x is equal to a variable. We conclude that no composite theory of \mathbb{T} after \mathbb{S} can exist. \square

Theorem 5.28 precludes even more distributive laws:

Example 5.29 (Multiset and Powerset Monad: Filling in the Gap). The theory of commutative monoids, presenting the multiset monad, does not have an idempotent term. Therefore, it has so far been unaffected by our no-go theorems. It does, however, have a unital term, bringing it in scope of Theorem 5.28. From Manes and Mulry [44, Theorem 4.3.4] we know that there are distributive laws $M \circ M \Rightarrow M \circ M$ and $M \circ P \Rightarrow P \circ M$, where M is the multiset monad and P the powerset monad. We already know that the powerset monad does not distribute over itself, which leaves the combination $P \circ M \Rightarrow M \circ P$. Theorem 5.28 fills this gap, showing there is no distributive law of that type.

	M	P
M	✓	✓
P	×	×

5.3.4 Concerning Commutativity

In Theorems 5.20 and 5.28 we require the special term t to be commutative in order to establish that no composite theory exists. In Theorem 5.25 this commutativity was generalised to the weaker requirement of stability under the action of a fixed-point free permutation. This raises the question of whether commutativity-like axioms are needed in this type of proof at all. In fact, this is not the case, and a similar no-go theorem can be established under modified assumptions that make no use of commutativity.

Theorem 5.30. *Let \mathbb{S} and \mathbb{T} be two algebraic theories. If there are terms:*

$$2 \vdash_{\mathbb{S}} s \quad \text{and} \quad 2 \vdash_{\mathbb{T}} t,$$

such that axioms (S1), (S2), (S3), (T2), and (T3) hold, and:

(T7) For all terms $t' \in \mathbb{T}$, and each variable a :

$$\Gamma \vdash a =_{\mathbb{T}} t' \quad \Rightarrow \quad \{a\} \vdash t'.$$

(T8) For all terms $t' \in \mathbb{T}$:

$$\Gamma \vdash t(a, b) =_{\mathbb{T}} t' \quad \Rightarrow \quad \neg(\emptyset \vdash t').$$

Then there is no composite theory of \mathbb{T} after \mathbb{S} .

Remark 5.31. Axiom (T7) is the same as axiom (S2), but now we require it to hold for \mathbb{T} as well as \mathbb{S} . Axiom (T8) states that the term $t(a, b)$ is not equal to a constant in \mathbb{T} .

Proof. Assume by way of a contradiction that a composite theory \mathbb{U} of \mathbb{T} after \mathbb{S} exists. Then as \mathbb{U} is composite, the separation axiom tells us that there exist $X \vdash t'$ and $\Gamma \vdash s'_x$ for each variable $x \in \text{var}(t')$ such that:

$$s(t(a, b), t(c, d)) =_{\mathbb{U}} t'[s'_x/x]. \quad (5.14)$$

As in previous proofs, we use various substitutions to learn more about the terms t' and all s'_x . The first substitution reduces the left hand side of Equation (5.14)

to a term involving just $t(a, b)$. This allows us to use essential uniqueness to get information about s'_x . Define substitution f_1 as follows:

$$\begin{aligned} f_1(a) &= a \\ f_1(b) &= b \\ f_1(c) &= a \\ f_1(d) &= b \end{aligned}$$

Then from Equation (5.14) we conclude:

$$\begin{aligned} & s(t(a, b), t(c, d)) =_{\mathbb{U}} t'[s'_x/x] \\ \Rightarrow & \{ \text{axiom of substitution} \} \\ & s(t(a, b)[f_1], t(c, d)[f_1]) =_{\mathbb{U}} t'[s'_x[f_1]/x] \\ \Rightarrow & \{ \text{applying the substitution on the left hand side} \} \\ & s(t(a, b), t(a, b)) =_{\mathbb{U}} t'[s'_x[f_1]/x] \\ \Rightarrow & \{ \text{Assumption (S1) : } s \text{ is idempotent} \} \\ & t(a, b) =_{\mathbb{U}} t'[s'_x[f_1]/x]. \end{aligned}$$

We now have two separated terms that are equal to each other, so by essential uniqueness, there are functions $g_1 : \{a, b\} \rightarrow Z$ and $g_2 : X \rightarrow Z$ such that:

$$t[g_1] =_{\mathbb{T}} t'[g_2], \quad (5.15)$$

and, for all $x \in \text{var}(t')$:

$$\begin{aligned} g_1(a) = g_2(x) &\Leftrightarrow a =_{\mathbb{S}} s'_x[f_1] \\ g_1(b) = g_2(x) &\Leftrightarrow b =_{\mathbb{S}} s'_x[f_1]. \end{aligned}$$

By assumption (T3), we must have $g_2(x) = g_1(a)$ or $g_2(x) = g_1(b)$, which means:

$$a =_{\mathbb{S}} s'_x[f_1] \quad \text{or} \quad b =_{\mathbb{S}} s'_x[f_1].$$

Then using assumption (S2), for all s'_x :

$$\{a, c\} \vdash s'_x \quad \text{or} \quad \{b, d\} \vdash s'_x. \quad (5.16)$$

We can now split the set of variables $\text{var}(t')$ into two disjoint subsets:

$$X_1 = \{x \mid \{a, c\} \vdash s'_x\} \quad (5.17)$$

$$X_2 = \{x \mid \{b, d\} \vdash s'_x\}. \quad (5.18)$$

The aim of the rest of the proof will be to show that $\text{var}(t') = \emptyset$, which will give a contradiction with assumption (T8). For this, we will need some more substitutions. Define a second partial function f_2 as follows:

$$\begin{aligned} f_2(a) &= a \\ f_2(b) &= a \\ f_2(c) &= b \\ f_2(d) &= b \end{aligned}$$

Applying this substitution to Equation (5.14):

$$\begin{aligned} & s(t(a, b), t(c, d)) =_{\mathbb{U}} t'[s'_x/x] \\ \Rightarrow & \{ \text{axiom of substitution} \} \\ & s(t(a, b)[f_2], t(c, d)[f_2]) =_{\mathbb{U}} t'[s'_x[f_2]/x] \\ \Rightarrow & \{ \text{applying the substitution on the left hand side} \} \\ & s(t(a, a), t(b, b)) =_{\mathbb{U}} t'[s'_x[f_2]/x] \\ \Rightarrow & \{ \text{Assumption (T2) : } t \text{ is idempotent} \} \\ & s(a, b) =_{\mathbb{U}} t'[s'_x[f_2]/x]. \end{aligned}$$

This is the same as:

$$y[s(a, b)/y] =_{\mathbb{U}} t'[s'_x[f_2]/x].$$

Again we have two separated terms that are equal, allowing us to use essential uniqueness. We conclude that there are functions $g_3 : \{y\} \rightarrow Z$ and $g_4 : X \rightarrow Z$ such that:

$$y[g_3] =_{\mathbb{T}} t'[g_4],$$

and:

$$g_3(y) = g_4(x) \Leftrightarrow s(a, b) =_{\mathbb{S}} s'_x[f_2].$$

By assumption (T7):

$$\{g_3(y)\} \vdash t'[g_4].$$

So for all $x \in \text{var}(t')$:

$$s'_x[f_2] =_{\mathbb{S}} s(a, b). \tag{5.19}$$

That is, under substitution f_2 , all the s'_x are equal to $s(a, b)$. The next step is designed to negate the effect of substitution f_2 , and hence fully understand each s'_x . We know from Equation (5.16) that the variables appearing in s'_x are different depending on

whether $x \in X_1$ or $x \in X_2$, and we therefore need to treat those cases separately. Starting with $x \in X_1$, consider the partial function f_3 :

$$\begin{aligned} f_3(a) &= a \\ f_3(b) &= c \\ f_3(c) &= c \\ f_3(d) &= d \end{aligned}$$

This substitution will act as an ‘inverse’ for f_2 , as will become clear in the following argument. Combining Equations (5.16) and (5.19):

$$\begin{aligned} & s'_x[f_2][f_3] \\ = & \{ \text{writing out the substitutions} \} \\ & s'_x[a/a, a/b, b/c, b/d][a/a, c/b, c/c, d/d] \\ = & \{ \text{ignoring the identity substitutions} \} \\ & s'_x[a/b, b/c, b/d][c/b] \\ = & \{ x \in X_1 \text{ so } \{a, c\} \vdash s'_x \} \\ & s'_x[b/c][c/b] \\ = & \{ \text{the second substitution is the inverse of the first} \} \\ & s'_x. \end{aligned}$$

Since $s'_x[f_2] =_{\mathbb{S}} s(a, b)$ by Equation (5.19), we conclude for all $x \in X_1$:

$$\begin{aligned} & s'_x[f_2] =_{\mathbb{S}} s(a, b) \\ \Rightarrow & \{ \text{axiom of substitution} \} \\ & s'_x[f_2][f_3] =_{\mathbb{S}} s(a, b)[f_3] \\ \Rightarrow & \{ \text{by the above: } s'_x[f_2][f_3] = s'_x \} \\ & s'_x =_{\mathbb{S}} s(a, b)[f_3] \\ \Rightarrow & \{ \text{applying } f_3 \} \\ & s'_x =_{\mathbb{S}} s(a, c). \end{aligned} \tag{5.20}$$

So for $x \in X_1$, we know that $s'_x =_{\mathbb{S}} s(a, c)$. A similar line of reasoning can be followed for $x \in X_2$. To negate substitution f_2 for these s'_x , we need the following substitution:

$$\begin{aligned}
f_4(a) &= b \\
f_4(b) &= d \\
f_4(c) &= c \\
f_4(d) &= d
\end{aligned}$$

The rest of the argument is the same, leading to the conclusion that for all $x \in X_2$, $s'_x =_{\mathbb{S}} s(b, d)$. We now have all the information about the s'_x that we need. We start working towards a contradiction with yet another substitution. This time, it is a substitution of *terms* for variables:

$$\begin{aligned}
f_5(a) &= t(a, b) \\
f_5(b) &= t(a, b) \\
f_5(c) &= t(a, a) \\
f_5(d) &= t(b, b)
\end{aligned}$$

These terms are chosen in such a way that the left hand side of Equation (5.14) reduces to $t(a, b)$ after substitution with f_5 , so that we can use essential uniqueness. On the right hand side, the substitution creates \mathbb{S} -terms with \mathbb{T} -terms in them. Separating these terms into \mathbb{T} -terms of \mathbb{S} -terms will yield new information, and eventually the contradiction.

So, starting from Equation (5.14):

$$\begin{aligned}
& s(t(a, b), t(c, d)) =_{\mathbb{U}} t'[s'_x/x] \\
\Rightarrow & \{ \text{axiom of substitution} \} \\
& s(t(a, b)[f_5], t(c, d)[f_5]) =_{\mathbb{U}} t'[s'_x[f_5]/x] \\
\Rightarrow & \{ \text{applying the substitution on the left hand side} \} \\
& s(t(t(a, b), t(a, b)), t(t(a, a), t(b, b))) =_{\mathbb{U}} t'[s'_x[f_5]/x] \\
\Rightarrow & \{ t \text{ is idempotent} \} \\
& s(t(a, b), t(a, b)) =_{\mathbb{U}} t'[s'_x[f_5]/x] \\
\Rightarrow & \{ s \text{ is idempotent} \} \\
& t(a, b) =_{\mathbb{U}} t'[s'_x[f_5]/x]. \tag{5.21}
\end{aligned}$$

Before we can apply essential uniqueness to Equation (5.21), we need to separate the right hand side of this equation. Remember from Equation (5.20) that $s'_x =_{\mathbb{S}} s(a, c)$

or $s'_x =_{\mathbb{S}} s(b, d)$, depending on whether $x \in X_1$ or $x \in X_2$. So, for $x \in X_1$:

$$\begin{aligned}
& s'_x =_{\mathbb{S}} s(a, c) \\
\Rightarrow & \{ \text{axiom of substitution} \} \\
& s'_x[f_5] =_{\mathbb{U}} s(a, c)[f_5] \\
\Rightarrow & \{ \text{applying the substitution on the right hand side} \} \\
& s'_x[f_5] =_{\mathbb{U}} s(t(a, b), t(a, a)) \\
\Rightarrow & \{ \text{substitution: } a/c, a/d \} \\
& s'_x[f_5] =_{\mathbb{U}} s(t(a, b), t(c, d)[a/c, a/d]) \\
\Rightarrow & \{ \text{Equation (5.14)} \} \\
& s'_x[f_5] =_{\mathbb{U}} t'[s'_y[a/c, a/d]/y],
\end{aligned}$$

where we know from Equation (5.20) that for $y \in X_1$, $s'_y =_{\mathbb{S}} s(a, c)$ and for $y \in X_2$, $s'_y =_{\mathbb{S}} s(b, d)$. Similarly, for $x \in X_2$:

$$\begin{aligned}
& s'_x =_{\mathbb{S}} s(b, d) \\
\Rightarrow & \{ \text{axiom of substitution} \} \\
& s'_x[f_5] =_{\mathbb{U}} s(b, d)[f_5] \\
\Rightarrow & \{ \text{applying the substitution on the right hand side} \} \\
& s'_x[f_5] =_{\mathbb{U}} s(t(a, b), t(b, b)) \\
\Rightarrow & \{ \text{substitution: } b/c, b/d \} \\
& s'_x[f_5] =_{\mathbb{U}} s(t(a, b), t(c, d)[b/c, b/d]) \\
\Rightarrow & \{ \text{Equation (5.14)} \} \\
& s'_x[f_5] =_{\mathbb{U}} t'[s'_y[b/c, b/d]/y],
\end{aligned}$$

where we know from Equation (5.20) that for $y \in X_1$, $s'_y =_{\mathbb{S}} s(a, c)$ and for $y \in X_2$, $s'_y =_{\mathbb{S}} s(b, d)$. And so, continuing from Equation (5.21):

$$\begin{aligned}
& t(a, b) =_{\mathbb{U}} t'[s'_x[f_5]/x] \\
\Rightarrow & t(a, b) =_{\mathbb{U}} t'[t'[s'_y[a/c, a/d]/y]/x \in X_1, \\
& \quad t'[s'_y[b/c, b/d]/y]/x \in X_2],
\end{aligned}$$

where $s'_y =_{\mathbb{S}} s(a, c)$ for $y \in X_1$ and $s'_y =_{\mathbb{S}} s(b, d)$ for $y \in X_2$. We can now apply essential uniqueness, and use property (T3) to conclude that both:

$$a =_{\mathbb{S}} s'_y[a/c, a/d] \quad \text{or} \quad b =_{\mathbb{S}} s'_y[a/c, a/d] \quad (5.22)$$

$$a =_{\mathbb{S}} s'_y[b/c, b/d] \quad \text{or} \quad b =_{\mathbb{S}} s'_y[b/c, b/d]. \quad (5.23)$$

For $y \in X_1$, however:

$$\begin{aligned} s'_y[b/c, b/d] &=_{\mathbb{S}} s(a, c)[b/c, b/d] \\ &= s(a, b). \end{aligned}$$

So, to satisfy equation (5.23), we conclude that $s(a, b) =_{\mathbb{S}} a$ or $s(a, b) =_{\mathbb{S}} b$. By property (S2), this means that $\{a\} \vdash s(a, b)$ or $\{b\} \vdash s(a, b)$. This contradicts property (S3). And so we must conclude that $X_1 = \emptyset$. Similarly, for $y \in X_2$:

$$\begin{aligned} s'_y[a/c, a/d] &=_{\mathbb{S}} s(b, d)[a/c, a/d] \\ &= s(b, a). \end{aligned}$$

In order to satisfy equation 5.22, we must have $s(b, a) =_{\mathbb{S}} a$ or $s(b, a) =_{\mathbb{S}} b$. By property (S2), this means that $\{a\} \vdash s(b, a)$ or $\{b\} \vdash s(b, a)$, which contradicts property (S3). And so we must also conclude that $X_2 = \emptyset$. Therefore:

$$\begin{aligned} \text{var}(t') &= X_1 \cup X_2 \\ &= \emptyset \cup \emptyset \\ &= \emptyset. \end{aligned}$$

However, from Equation (5.15) we know: $t[g_1] =_{\mathbb{T}} t'[g_2]$, and from property (T8) we know that:

$$\neg(\emptyset \vdash t'[g_2]).$$

So, $\text{var}(t')$ cannot be empty. Contradiction! Hence no composite theory of \mathbb{T} after \mathbb{S} can exist. \square

Example 5.32. If we consider the algebraic theory of an idempotent binary operation, Theorem 5.30 shows that the induced monad cannot distribute over itself. This remains true if we add either units or associativity, showing various non-commutative variants of non-determinism cannot be distributed over themselves.

Similarly, if we denote any of these monads by T , there is no distributive law $D \circ T \Rightarrow T \circ D$, where D is the distribution monad.

Non-Example 5.33 (Reader Monad). The presentation of the binary reader monad given in Example 2.32 satisfies:

$$x = (x * y) * (z * x).$$

However, this theory has no term t satisfying both axioms (T2) and (T3). So as expected, we cannot apply Theorem 5.30 to the binary reader monad.

5.4 No-Go Theorems Based on Units

The next and last class of theorems we introduce forms again a set of generalisations of a specific counterexample, this time showing that there is no distributive law for the list monad over itself. However, we will not prove this counterexample separately as we did in previous sections, because its proof is as long and as complicated as its generalisations. So instead, we advise the reader to keep the list monad in mind when reading the theorems and proofs of this section for the first time.

The list monad is quite similar to the multiset monad, and we observed in Example 2.14 that the “times over plus” law of Equation (2.1) induces a distributive law for the multiset monad over itself. If we assume this also yields a distributive law for the list monad over itself, then from one of the multiplication axioms:

$$\lambda([[a, b], [c, d]]) = [[a, c], [a, d], [b, c], [b, d]],$$

whilst from the other:

$$\lambda([[a, b], [c, d]]) = [[a, c], [b, c], [a, d], [b, d]].$$

These two statements are incompatible, so the list monad cannot distribute over itself in this way. However, not all distributive laws resemble the distributivity of times over plus, so from this observation alone we cannot yet rule out the possibility of a distributive law for the list monad over itself. In fact, Manes and Mulry found three further distributive laws for the *non-empty* list monad over itself [44, Example 5.1.9], [45, Example 4.10], see also Example 2.15. However, all of these fail to extend to distributive laws for the full list monad over itself.

The theorems in this section first prove that *if* there is a distributive law for the list monad over itself, then it *has* to be the times over plus law. This is captured in Theorem 5.37 and the lemmas leading up to this theorem. Proposition 5.1 is once again a key ingredient in the proofs for these. The observation above then shows that this distributive law is impossible, and hence no distributive law exists for the list monad over itself. The general statement and precise argument are presented in Theorem 5.42.

The algebraic equation central to this section is unitality. In addition, the **abides** equation (**above-besides**, [6]) will be important:

$$(a * b) * (c * d) = (a * c) * (b * d). \tag{5.24}$$

We will be looking at theories in which this equation does *not* hold. This is made precise in property (T5)b below.

Throughout this section, we will consider two algebraic theories \mathbb{S} and \mathbb{T} . For \mathbb{S} we identify the following properties:

(S1) For any two terms s', s'' :

$$\emptyset \vdash s' \wedge \Gamma \vdash s' =_{\mathbb{S}} s'' \quad \Rightarrow \quad \emptyset \vdash s''.$$

(S2) For any term s' and variable x :

$$\Gamma \vdash s' =_{\mathbb{S}} x \quad \Rightarrow \quad \{x\} \vdash s'.$$

(S3) \mathbb{S} has an n -ary term s ($n \geq 1$), for which there is a substitution $f : \text{var}(s) \rightarrow \mathbb{S}$ such that for any $x \in \text{var}(s)$:

$$\Gamma \vdash s[f(y)/y \neq x] =_{\mathbb{S}} x.$$

(S4) For any n -ary term s' ($n \geq 1$), there is a substitution $f : \text{var}(s') \rightarrow \mathbb{S}$ such that for any $x \in \text{var}(s')$:

$$\Gamma \vdash s'[f(y)/y \neq x] =_{\mathbb{S}} x.$$

(S5) \mathbb{S} has a binary term s such that:

(a) e_s is a unit for s :

$$\{x\} \vdash s(x, e_s) =_{\mathbb{S}} x =_{\mathbb{S}} s(e_s, x).$$

(b) s is idempotent:

$$\{x\} \vdash s(x, x) =_{\mathbb{S}} x.$$

And for \mathbb{T} :

(T1) For all terms $X \vdash t'$, constant $e_{\mathbb{T}}$, and any variable substitution $f : X \rightarrow Y$:

$$Y \vdash t'[f] =_{\mathbb{T}} e_{\mathbb{T}} \quad \Rightarrow \quad X \vdash t' =_{\mathbb{T}} e_{\mathbb{T}}.$$

(T2) For any two terms t', t'' :

$$\emptyset \vdash t' \wedge \Gamma \vdash t' =_{\mathbb{T}} t'' \quad \Rightarrow \quad \emptyset \vdash t''.$$

(T3) For any term t' and variable x :

$$\Gamma \vdash t' =_{\mathbb{T}} x \quad \Rightarrow \quad \{x\} \vdash t'.$$

(T4) \mathbb{T} has a constant $e_{\mathbb{T}}$.

(T5) \mathbb{T} has a binary term t such that:

(a) e_t is a unit for t :

$$\{x\} \vdash t(x, e_t) =_{\mathbb{T}} x =_{\mathbb{T}} t(e_t, x).$$

(b) The abides equation does not hold in \mathbb{T} :

$$\begin{aligned} \Gamma \vdash t(t(x, y), t(z, w)) &=_{\mathbb{T}} t(t(x, z), t(y, w)) \\ \Rightarrow \exists \vdash t(t(x, y), t(z, w)). \end{aligned}$$

Remark 5.34 (Interpretation of Axioms). The properties (S1), (S2), (T2), (T3) are all constraints on the variables appearing in terms. (S1) and (T2) read: “Any term provably equal to a constant cannot have any variables itself”. This is, for example, not the case for any theory involving multiplicative zeroes. In the theory of rings, $0 * x = 0$, and since the term $0 * x$ has a variable, it does not satisfy (S1)/(T2).

(S2) and (T3) read: “Any term provably equal to a variable only contains that single variable”. Idempotent terms are examples of terms that equal a variable, satisfying this condition. In theories with absorption axioms, such as the equation $x \vee (x \wedge y) = x$ from bounded lattices, properties (S2)/(T3) do not hold.

Properties (S3) and (S4) are generalisations of idempotence and unital equations. They require that terms can be reduced to variables via a suitable substitution. Idempotence and unitality are both instances of this. Idempotence requires the substitution to change all variables to x : $s(x, y)[x/x, x/y] = s(x, x) = x$, while unitality uses a substitution of a constant for all but one variable: $s(x, y)[e_s/y] = s(x, e_s) = x$. The difference between (S3) and (S4) is the quantifier.

Property (T1) is a weaker version of (T2), focussing on the provability of an equality between a term and a constant, rather than restricting the variables appearing in that term. It reads: “If a variable substitution of term t' is provably equal to a constant, then t' is already provably equal to that constant.” The usefulness of this property compared to (T2) is that it allows for equations such as $0 * x = 0$, which were forbidden by (T2).

Notice that property (T2) implies (T1): if $t'[f] = e_{\mathbb{T}}$ then (T2) requires $t'[f]$ to contain no variables. Since f is a variable substitution, this means t' already had no variables, and hence $t' = t'[f] = e_{\mathbb{T}}$, so (T1) is satisfied. This justifies our claim that one is a weaker version of the other.

Also notice that (S5)a and (S5)b both imply (S3).

Example 5.35. If a theory \mathbb{S} has a presentation in which all operations are either idempotent or have a unit, then an easy induction shows that \mathbb{S} will satisfy (S4). More precisely, if for every $s' \in \Sigma^{\mathbb{S}}$, either:

- s' is idempotent, that is: $s'[x/y \neq x] =_{\mathbb{S}} x$, or:
- s' has a unit $e_{s'}$: $s'[e_{s'}/y \neq x] =_{\mathbb{S}} x$,

then \mathbb{S} satisfies (S4).

Example 5.36 (Algebraic Properties of Key Monads).

- The list monad, presented by the theory of monoids, satisfies (S1) and (S2). The monoid multiplication satisfies (S5)a and hence also (S3) and even (S4), but the theory of monoids does not satisfy (S5)b. The equation $(x*y)*(z*w) = (x*z)*(y*w)$ holds in the theory of monoids if and only if $y = z$, and so it satisfies all of (T1), (T2), (T3), (T4), (T5)a, and (T5)b.
- The powerset monad is presented by the theory of join semilattices, which satisfies (S5)b in addition to (S1), (S2), (S3), (S4), and (S5)a. However, this theory does not have property (T5)b as the join is commutative and associative and so satisfies the abides equation (5.24). Properties (T1), (T2), (T3), (T4), and (T5)a still hold.
- The exception monad corresponds to an algebraic theory with a signature containing constants for each exception, and no axioms. It satisfies (S1), (S2), and (S4). It does not satisfy (S3), (S5)a, and (S5)b as there are no binary terms. Similarly, it satisfies (T1), (T2), (T3), and (T4), but not (T5)a or (T5)b.

5.4.1 The One Distributive Law, If It Exists

Needing just the properties (S3), (T1), and (T4), Proposition 5.1 already greatly restricts the possibilities for a distributive law between monads S and T . We will now see that if both \mathbb{S} and \mathbb{T} have binary terms with units, then in a composite theory, the binary of \mathbb{S} distributes over the binary of \mathbb{T} like times over plus in Equation (2.1). For the monads corresponding to these theories, this means that there is only one candidate distributive law to consider.

Theorem 5.37 (Times over Plus Theorem). *Let \mathbb{S} and \mathbb{T} be two algebraic theories, satisfying (S1), (S2), (S4) and (T2), (T3), (T4) respectively. Assume furthermore that there are terms:*

$$2 \vdash_{\mathbb{S}} s \quad \text{and} \quad 2 \vdash_{\mathbb{T}} t,$$

satisfying (S5)a and (T5)a respectively. Finally, let \mathbb{U} be a composite theory of \mathbb{T} after \mathbb{S} . Then s distributes over t :

$$s(t(y_1, y_2), x_0) =_{\mathbb{U}} t(s(y_1, x_0), s(y_2, x_0)) \quad (5.25)$$

$$s(x_0, t(y_1, y_2)) =_{\mathbb{U}} t(s(x_0, y_1), s(x_0, y_2)). \quad (5.26)$$

We derive this distributional behaviour in three stages, relying as always on separation and essential uniqueness in a composite theory. Suppose that $t'[s'_x/x]$ is a separated term such that $s(t(y_1, y_2), x_0) =_{\mathbb{U}} t'[s'_x/x]$, then we derive the following about $t'[s'_x/x]$:

1. First we prove which variables appear in the terms s'_x of the separated term:
 $\text{var}(s'_x) = \{y_1, x_0\}$ or $\text{var}(s'_x) = \{y_2, x_0\}$.
2. Then, we prove that each of the s'_x is either equal to $s(y_1, x_0)$ or to $s(y_2, x_0)$.
3. Finally, we derive that the separated term $t'[s'_x/x]$ has to be equal to $t(s(y_1, x_0), s(y_2, x_0))$.

The proofs of these three stages are quite long. They are separated into lemmas to help keep track of the main line of reasoning.

Lemma 5.38. *Let \mathbb{S} and \mathbb{T} be two algebraic theories satisfying (S1), (S2), (S4), and (T2), (T4) respectively. Assume furthermore that there are terms:*

$$2 \vdash_{\mathbb{S}} s \quad \text{and} \quad 2 \vdash_{\mathbb{T}} t,$$

satisfying (S5)a and (T5)a respectively. Finally, let \mathbb{U} be a composite theory of \mathbb{T} after \mathbb{S} . Then there is a \mathbb{T} -term $X \vdash t'$ and there is a family of \mathbb{S} -terms $s'_x, x \in X$ such that:

$$s(t(y_1, y_2), x_0) =_{\mathbb{U}} t'[s'_x/x],$$

and for each $x \in \text{var}(t')$:

$$\text{var}(s'_x) = \{y_1, x_0\} \quad \text{or} \quad \text{var}(s'_x) = \{y_2, x_0\}.$$

Moreover, there is an x such that $\text{var}(s'_x) = \{y_1, x_0\}$ and an x such that $\text{var}(s'_x) = \{y_2, x_0\}$.

Similarly, there is a \mathbb{T} -term $X' \vdash t''$ and there is a family of \mathbb{S} -terms $s''_{x'}, x' \in X'$ such that:

$$s(x_0, t(y_1, y_2)) =_{\mathbb{U}} t''[s''_{x'}/x'],$$

and for each $x' \in \text{var}(t'')$:

$$\text{var}(s''_{x'}) = \{y_1, x_0\} \quad \text{or} \quad \text{var}(s''_{x'}) = \{y_2, x_0\}.$$

Furthermore, there is an x' such that $\text{var}(s''_{x'}) = \{y_1, x_0\}$ and an x' such that $\text{var}(s''_{x'}) = \{y_2, x_0\}$.

Proof. We only explicitly prove the statements for $s(t(y_1, y_2), x_0)$. The proof for $s(x_0, t(y_1, y_2))$ is similar, making the same substitutions and arguments, just having the variable x_0 on the left instead of on the right in the term s , and therefore using the left rather than the right unital equation to arrive at Equation(5.28).

From the fact that \mathbb{U} is a composite of the theories \mathbb{S} and \mathbb{T} , we know that every term in \mathbb{U} is equal to a separated term. And so, there is a $X \vdash t'$ and there is a family $s'_x, x \in X$ such that:

$$s(t(y_1, y_2), x_0) =_{\mathbb{U}} t'[s'_x/x]. \quad (5.27)$$

We substitute $x_0 \mapsto e_s$ in Equation (5.27). This yields:

$$\begin{aligned} s(t(y_1, y_2), e_s) &=_{\mathbb{U}} t'[s'_x[e_s/x_0]/x] \\ \Rightarrow \quad \{ e_s \text{ is the unit of } s \} \\ t(y_1, y_2) &=_{\mathbb{U}} t'[s'_x[e_s/x_0]/x]. \end{aligned} \quad (5.28)$$

By the essential uniqueness property, we conclude that there are functions:

$$f : \{y_1, y_2\} \rightarrow Z, \quad f' : X \rightarrow Z,$$

such that:

$$t(y_1, y_2)[f] =_{\mathbb{T}} t'[f']. \quad (5.29)$$

Furthermore, whenever $f(y_1) = f'(x)$ or $f(y_2) = f'(x)$, we have respectively:

$$y_1 =_{\mathbb{S}} s'_x[e_s/x_0] \quad (5.30)$$

$$y_2 =_{\mathbb{S}} s'_x[e_s/x_0]. \quad (5.31)$$

Since we assume variables y_1 and y_2 to be distinct, essential uniqueness also gives us $f(y_1) \neq f(y_2)$.

We analyse Equation (5.29) more closely, comparing the variables appearing in both $t(y_1, y_2)[f]$ and $t'[f']$. First, we show that $\{f'(x) \mid x \in \text{var}(t')\} \subseteq \{f(y_1), f(y_2)\}$. This follows from the following equalities:

$$\begin{aligned}
& e_t \\
& \stackrel{=_{\mathbb{T}}}{=} \{ e_t \text{ is the unit for } t \} \\
& \quad t(e_t, e_t) \\
& \stackrel{=_{\mathbb{T}}}{=} \{ \text{substitution} \} \\
& \quad t(f(y_1), f(y_2))[e_t/f(y_1), e_t/f(y_2)] \\
& \stackrel{=_{\mathbb{T}}}{=} \{ \text{Equation (5.29)} \} \\
& \quad t'[f'] [e_t/f(y_1), e_t/f(y_2)].
\end{aligned}$$

So: $e_t \stackrel{=_{\mathbb{T}}}{=} t'[f'] [e_t/f(y_1), e_t/f(y_2)]$. Then by assumption (T2):

$$\text{var}(t'[f'] [e_t/f(y_1), e_t/f(y_2)]) = \emptyset.$$

Therefore, $t'[f']$ can contain no other variables than $f(y_1)$ and $f(y_2)$. That is:

$$\{f'(x) \mid x \in \text{var}(t')\} \subseteq \{f(y_1), f(y_2)\}. \quad (5.32)$$

Next, we show that both $f(y_1)$ and $f(y_2)$ need to appear in $t'[f']$. Suppose that $f(y_1)$ does not appear in $t'[f']$. Then from Equation (5.32) we know that for all $x \in \text{var}(t')$, $f'(x) = f(y_2)$. Then:

$$\begin{aligned}
& f(y_1) \\
& \stackrel{=_{\mathbb{T}}}{=} \{ e_t \text{ is the unit for } t \} \\
& \quad t(f(y_1), e_t) \\
& \stackrel{=_{\mathbb{T}}}{=} \{ \text{substitution} \} \\
& \quad t(f(y_1), f(y_2))[e_t/f(y_2)] \\
& \stackrel{=_{\mathbb{T}}}{=} \{ \text{Equation (5.29)} \} \\
& \quad t'[f'] [e_t/f(y_2)] \\
& \stackrel{=_{\mathbb{T}}}{=} \{ \text{for all } x, f'(x) = f(y_2) \} \\
& \quad t'[e_t/x].
\end{aligned}$$

So: $f(y_1) \stackrel{=_{\mathbb{T}}}{=} t'[e_t/x]$, but this contradicts assumption (T2), because $\text{var}(t'[e_t/x]) = \emptyset$, since every free variable in t' has been substituted with the constant e_t , and $\text{var}(f(y_1)) = \{f(y_1)\} \neq \emptyset$.

So $f(y_1)$ has to appear in $t'[f']$. A similar line of reasoning yields the same conclusion for $f(y_2)$. Therefore, there is an x such that $f'(x) = f(y_1)$ and there is an x such that $f'(x) = f(y_2)$. In summary, if we define:

$$\begin{aligned} X_1 &= \{x \in \text{var}(t') \mid f'(x) = f(y_1)\} \\ X_2 &= \{x \in \text{var}(t') \mid f'(x) = f(y_2)\}, \end{aligned}$$

then we know that neither X_1 nor X_2 is empty and that $X_1 \cup X_2 = \text{var}(t')$.

We finally consider Equations (5.30) and (5.31) to reach a conclusion about the variables appearing in the terms s'_x . Since for all $x \in X_1 : f'(x) = f(y_1)$, we have by Equation (5.30) that $s'_x[e_s/x_0] =_{\mathbb{S}} y_1$. Similarly, for all $x \in X_2$, $s'_x[e_s/x_0] =_{\mathbb{S}} y_2$. By assumption (S2), we conclude that:

$$\forall x \in X_1 : \{x_0, y_1\} \vdash s'_x \quad (5.33)$$

$$\forall x \in X_2 : \{x_0, y_2\} \vdash s'_x. \quad (5.34)$$

In addition, since for any $x \in X_1$, $y_1 =_{\mathbb{S}} s'_x[e_s/x_0]$, we would have y_1 equal to a constant if y_1 would not appear in s'_x , contradicting assumption (S1). Similarly for y_2 and $s'_x, x \in X_2$. And so:

$$\forall x \in X_1 : y_1 \in \text{var}(s'_x) \quad (5.35)$$

$$\forall x \in X_2 : y_2 \in \text{var}(s'_x). \quad (5.36)$$

To prove that $x_0 \in \text{var}(s'_x)$ for all $x \in \text{var}(t')$, we substitute $x_0 \mapsto e_t$ in Equation (5.27):

$$s(t(y_1, y_2), e_t) =_{\mathbb{U}} t'[s'_x[e_t/x_0]/x].$$

By Proposition 5.1, $s(t(y_1, y_2), e_t) =_{\mathbb{U}} e_t$. Therefore we must have that also:

$$t'[s'_x[e_t/x_0]/x] =_{\mathbb{U}} e_t. \quad (5.37)$$

The left hand side of this equation might not be separated, since we substitute a \mathbb{T} -term inside \mathbb{S} -terms. We analyse the terms $s'_x[e_t/x_0]$ further to separate them into \mathbb{T} -terms of \mathbb{S} -terms. There are two cases: either $x_0 \in \text{var}(s'_x)$ or not.

- If $x_0 \in \text{var}(s'_x)$, then by property (S4): $s'_x[e_t/x_0] = e_t$, which is a separated term.
- If $x_0 \notin \text{var}(s'_x)$, then $s'_x[e_t/x_0] = s'_x$, which is also a separated term.

We conclude that $t'[s'_x[e_t/x_0]/x]$ is separated. It is our goal to show that we must have x_0 appearing in each s'_x . To this end, define:

$$X_3 = \{x \in \text{var}(t') \mid x_0 \in s'_x\}.$$

We will show that we must have $X_3 = \text{var}(t')$. We define:

$$t'' = t'[e_t/x \in X_3].$$

Then:

$$\begin{aligned} & t''[s'_x/x] \\ =_{\mathbb{U}} & \{ \text{definition of } t'' \} \\ & t'[e_t/x \in X_3, s'_x/x \notin X_3] \\ =_{\mathbb{U}} & \{ \text{for } x \in X_3 : s'_x[e_t/x_0] = e_t \\ & \quad \text{and for } x \notin X_3 : s'_x[e_t/x_0] = s'_x \} \\ & t'[s'_x[e_t/x_0]/x] \\ =_{\mathbb{U}} & \{ \text{Equation (5.37)} \} \\ & e_t. \end{aligned}$$

So we can apply essential uniqueness to the equation $t''[s'_x/x] =_{\mathbb{U}} e_t$. We conclude that there must be a variable substitution g such that $t''[g] =_{\mathbb{T}} e_t$. By property (T2) we conclude that $\text{var}(t''[g]) = \emptyset$ and hence also $\text{var}(t'') = \emptyset$. Since $t'' = t'[e_t/x \in X_3]$, we conclude that t' has no variables that are not in X_3 . In other words: $X_3 = \text{var}(t')$, and hence for all $x \in \text{var}(t')$, $x_0 \in \text{var}(s'_x)$.

This, together with Equations (5.33), (5.34), (5.35) and (5.36), proves that for all $x \in \text{var}(t')$:

$$\text{var}(s'_x) = \{y_1, x_0\} \quad \text{or} \quad \text{var}(s'_x) = \{y_2, x_0\}.$$

The fact that neither X_1 nor X_2 are empty means that this proves the lemma. \square

With the first step done, we move on to the second step:

Lemma 5.39. *Let \mathbb{S} and \mathbb{T} be two algebraic theories satisfying (S1), (S2), (S4) and (T2), (T3), (T4) respectively. Assume furthermore that there are terms:*

$$2 \vdash_{\mathbb{S}} s \quad \text{and} \quad 2 \vdash_{\mathbb{T}} t,$$

satisfying (S5)a and (T5)a respectively. Finally, let \mathbb{U} be a composite theory of \mathbb{T} after \mathbb{S} . Then there is a \mathbb{T} -term $X \vdash t'$ and there is a family of \mathbb{S} -terms $s'_x, x \in X$ such that:

$$s(t(y_1, y_2), x_0) =_{\mathbb{U}} t'[s'_x/x],$$

and for each $x \in \text{var}(t')$:

$$s'_x =_{\mathbb{S}} s(y_1, x_0) \quad \text{or} \quad s'_x =_{\mathbb{S}} s(y_2, x_0).$$

Moreover, there is an x such that $s'_x =_{\mathbb{S}} s(y_1, x_0)$ and an x such that $s'_x =_{\mathbb{S}} s(y_2, x_0)$.

Similarly, there is a \mathbb{T} -term $X' \vdash t''$ and there is a family of \mathbb{S} -terms $s''_{x'}, x' \in X'$ such that:

$$s(x_0, t(y_1, y_2)) =_{\mathbb{U}} t''[s''_{x'}/x'],$$

and for each $x' \in \text{var}(t'')$:

$$s''_{x'} =_{\mathbb{S}} s(x_0, y_1) \quad \text{or} \quad s''_{x'} =_{\mathbb{S}} s(x_0, y_2).$$

Moreover, there is an x' such that $s''_{x'} =_{\mathbb{S}} s(y_1, x_0)$ and an x' such that $s''_{x'} =_{\mathbb{S}} s(y_2, x_0)$.

Proof. Again, we only explicitly prove the statements for $s(t(y_1, y_2), x_0)$. The second half of the claim follows using the same arguments.

As \mathbb{U} is a composite theory, we know from the separation axiom that there is a \mathbb{T} -term $X \vdash t'$ and a family of \mathbb{S} -terms $s'_x, x \in X$ such that:

$$s(t(y_1, y_2), x_0) =_{\mathbb{U}} t'[s'_x/x].$$

We substitute $y_1 \mapsto e_t$:

$$\begin{aligned} & s(t(e_t, y_2), x_0) =_{\mathbb{U}} t'[s'_x[e_t/y_1]/x] \\ \Rightarrow & \quad \{ e_t \text{ is the unit of } t \} \\ & s(y_2, x_0) =_{\mathbb{U}} t'[s'_x[e_t/y_1]/x] \\ \Rightarrow & \quad \{ \text{showing that } s(y_2, x_0) \text{ is a separated term} \} \\ & z[s(y_2, x_0)/z] =_{\mathbb{U}} t'[s'_x[e_t/y_1]/x]. \end{aligned} \tag{5.38}$$

To use essential uniqueness, we need two separated terms. However, $t'[s'_x[e_t/y_1]/x]$ is a \mathbb{T} -term built out of \mathbb{S} -terms with possibly a \mathbb{T} -constant in them. So we need to separate this term. We use Proposition 5.1 in combination with our knowledge from Lemma 5.38 about the variables appearing in each s'_x to do this. Define:

$$\begin{aligned} X_1 &= \{x \in \text{var}(t') \mid \text{var}(s'_x) = \{y_1, x_0\}\} \\ X_2 &= \{x \in \text{var}(t') \mid \text{var}(s'_x) = \{y_2, x_0\}\}. \end{aligned}$$

From Lemma 5.38 we know that neither X_1 nor X_2 is empty and their union contains all variables in t' . For each $x \in X_1$, we use property (S4) to apply Proposition 5.1, which tells us $s'_x[e_t/y_1] =_{\mathbb{U}} e_t$. For each $x \in X_2$, we know that since y_1 does not appear in s'_x , we have $s'_x[e_t/y_1] =_{\mathbb{U}} s'_x$. Therefore:

$$t'[s'_x[e_t/y_1]/x] =_{\mathbb{T}} t'[e_t/x \in X_1, s'_x/x \in X_2]. \quad (5.39)$$

Next, define:

$$t'' = t'[e_t/x \in X_1].$$

Then $X_2 \vdash_{\mathbb{T}} t''$. We have:

$$\begin{aligned} & t''[s'_x/x] \\ =_{\mathbb{U}} & \{ \text{definition of } t'' \} \\ & t'[e_t/x \in X_1, s'_x/x \in X_2] \\ =_{\mathbb{U}} & \{ \text{Equation (5.39)} \} \\ & t'[s'_x[e_t/y_1]/x] \\ =_{\mathbb{U}} & \{ \text{Equation (5.38)} \} \\ & z[s(y_2, x_0)/z]. \end{aligned}$$

Now we can use the essential uniqueness property, and conclude that there are functions $f : \{z\} \rightarrow Z, f' : X_2 \rightarrow Z$ such that:

$$z[f(z)/z] =_{\mathbb{T}} t''[f'(x)/x]. \quad (5.40)$$

Furthermore, we have:

$$f'(x) = f(z) \Leftrightarrow s'_x =_{\mathbb{S}} s(y_2, x_0). \quad (5.41)$$

From Equation (5.40) and assumption (T3) we conclude that $\{f(z)\} \vdash t''[f'(x)/x]$. And hence for all $x \in X_2$, $f'(x) = f(z)$. So by Equation (5.41), for each $x \in X_2$: $s'_x =_{\mathbb{S}} s(y_2, x_0)$, which gives us half of the desired conclusion about each $s'_x, x \in \text{var}(t')$.

A similar argument using the substitution $y_2 \mapsto e_t$ instead of $y_1 \mapsto e_t$ leads to the conclusion that for each $x \in X_1$, we have $s'_x =_{\mathbb{S}} s(y_1, x_0)$. \square

And finally, we prove the last step, in which we show that s distributes over t . This yields a proof of Theorem 5.37. We restate the theorem for convenience:

Theorem 5.37 (Times over Plus Theorem). *Let \mathbb{S} and \mathbb{T} be two algebraic theories, satisfying (S1), (S2), (S4) and (T2), (T3), (T4) respectively. Assume furthermore that there are terms:*

$$2 \vdash_{\mathbb{S}} s \quad \text{and} \quad 2 \vdash_{\mathbb{T}} t,$$

satisfying (S5)a and (T5)a respectively. Finally, let \mathbb{U} be a composite theory of \mathbb{T} after \mathbb{S} . Then s distributes over t :

$$s(t(y_1, y_2), x_0) =_{\mathbb{U}} t(s(y_1, x_0), s(y_2, x_0)) \quad (5.25)$$

$$s(x_0, t(y_1, y_2)) =_{\mathbb{U}} t(s(x_0, y_1), s(x_0, y_2)). \quad (5.26)$$

Proof. Again, we only explicitly prove the first statement, the proof of the second statement is similar, using the appropriate parts of Lemmas 5.38 and 5.39.

From the separation axiom of composite theories and Lemma 5.39 we know that there is a \mathbb{T} -term $X \vdash t'$ and a family of \mathbb{S} -terms s'_x , $x \in X$ such that either $s'_x = s(y_1, x_0)$ or $s'_x = s(y_2, x_0)$ and:

$$s(t(y_1, y_2), x_0) =_{\mathbb{U}} t'[s'_x/x].$$

Define:

$$X_1 = \{x \in \text{var}(t') \mid s'_x = s(y_1, x_0)\}$$

$$X_2 = \{x \in \text{var}(t') \mid s'_x = s(y_2, x_0)\}.$$

Then, using the substitution $x_0 \mapsto e_s$, we get:

$$\begin{aligned} & t(y_1, y_2) \\ =_{\mathbb{U}} & \{ e_s \text{ is the unit of } s \} \\ & s(t(y_1, y_2), e_s) \\ =_{\mathbb{U}} & \{ \text{substitution} \} \\ & s(t(y_1, y_2), x_0)[e_s/x_0] \\ =_{\mathbb{U}} & \{ \text{Lemma 5.39} \} \\ & t'[s'_x[e_s/x_0]/x] \\ =_{\mathbb{U}} & \{ s'_x = s(y_1, x_0) \text{ or } s'_x = s(y_2, x_0) \\ & \text{and } e_s \text{ is the unit of } s \} \\ & t'[y_1/x \in X_1, y_2/x \in X_2]. \end{aligned}$$

So:

$$t(y_1, y_2) =_{\mathbb{U}} t'[y_1/x \in X_1, y_2/x \in X_2]. \quad (5.42)$$

We also have:

$$\begin{aligned}
& t'[s'_x/x] \\
& =_{\mathbb{U}} \{ \text{Lemma 5.39} \} \\
& \quad t'[s(y_1, x_0)/x \in X_1, s(y_2, x_0)/x \in X_2] \\
& =_{\mathbb{U}} \{ \text{Substitution: term = variable[term/variable]} \} \\
& \quad t'[y_1[s(y_1, x_0)/y_1]/x \in X_1, y_2[s(y_2, x_0)/y_2]/x \in X_2].
\end{aligned}$$

So we conclude:

$$\begin{aligned}
& t'[s'_x/x] \\
& =_{\mathbb{U}} \{ \text{by the reasoning above} \} \\
& \quad t'[y_1[s(y_1, x_0)/y_1]/x \in X_1, y_2[s(y_2, x_0)/y_2]/x \in X_2] \\
& =_{\mathbb{U}} \{ \text{Equation (5.42)} \} \\
& \quad t(y_1, y_2)[s(y_1, x_0)/y_1, s(y_2, x_0)/y_2] \\
& =_{\mathbb{U}} \{ \text{applying the substitution} \} \\
& \quad t(s(y_1, x_0), s(y_2, x_0)),
\end{aligned}$$

which proves the theorem. □

In suitable cases, Theorem 5.37 reduces the search space for distributive laws to a single possibility. From Proposition 3.7 we know that the action of distributive laws is determined by the separated terms in the composite theory. And so:

Corollary 5.40. *Let S and T be two monads presented by algebraic theories \mathbb{S} and \mathbb{T} , having signatures with at least one constant and one binary operation. If for both theories the constant acts as a unit for the binary operation and the theories further satisfy (S1), (S2), (S4), and (T2) and (T3) respectively, then any distributive law $S \circ T \Rightarrow T \circ S$ distributes the binary from \mathbb{S} over the binary from \mathbb{T} as in Equation (2.1).*

Example 5.41 (Unique Distributive Laws). Let S be any of the monads tree, list, or multiset. Then the corresponding algebraic theory \mathbb{S} contains only linear equations (see Example 2.32). Let T be either the multiset or powerset monad. Since the multiset and powerset monads are commutative monads, we know that there is a distributive law $S \circ T \Rightarrow T \circ S$ [44, Theorem 4.3.4]. Corollary 5.40 states that this distributive law is unique. In particular, the distributive law for the multiset monad over itself mentioned in Example 2.14 is unique.

5.4.2 Lacking the Abides Property: a No-Go Theorem

With Theorem 5.37 narrowing down the possible distributive laws for two monads, it is easier to find cases in which no distributive law can exist at all. We identify two properties that clash with Theorem 5.37, one for \mathbb{T} and one for \mathbb{S} . In this section we show that not satisfying the abides equation, property (T5)b, in combination with Theorem 5.37 prevents the existence of a distributive law. In the next section we do the same for idempotence, property (S5)b. Both properties are sufficiently common to cover a broad class of monads.

Theorem 5.42 (No-Go Theorem: Lacking Abides). *Let \mathbb{S} and \mathbb{T} be algebraic theories satisfying the conditions of Theorem 5.37, and assume that the binary t in \mathbb{T} promised by (T5)a additionally satisfies (T5)b, then there does not exist a composite theory of \mathbb{T} after \mathbb{S} .*

Proof. Suppose there exists a composite theory \mathbb{U} . Given Theorem 5.37, we compute a separated term equal in \mathbb{U} to $s(t(y_1, y_2), t(y_3, y_4))$:

$$\begin{aligned}
& s(t(y_1, y_2), t(y_3, y_4)) \\
=_{\mathbb{U}} & \{ \text{Substitution} \} \\
& s(t(y_1, y_2), x_0)[t(y_3, y_4)/x_0] \\
=_{\mathbb{U}} & \{ \text{Equation (5.25) from Theorem 5.37} \} \\
& t(s(y_1, x_0), s(y_2, x_0))[t(y_3, y_4)/x_0] \\
=_{\mathbb{U}} & \{ \text{Substitution} \} \\
& t(s(y_1, t(y_3, y_4)), s(y_2, t(y_3, y_4))) \\
=_{\mathbb{U}} & \{ \text{Equation (5.26) from Theorem 5.37} \} \\
& t(t(s(y_1, y_3), s(y_1, y_4)), t(s(y_2, y_3), s(y_2, y_4))). \tag{5.43}
\end{aligned}$$

Notice that we made a choice, taking out the right t term in

$$s(t(y_1, y_2), t(y_3, y_4)) =_{\mathbb{U}} s(t(y_1, y_2), x_0)[t(y_3, y_4)/x_0],$$

rather than the left:

$$s(t(y_1, y_2), t(y_3, y_4)) =_{\mathbb{U}} s(x_0, t(y_3, y_4))[t(y_1, y_2)/x_0].$$

The latter option yields:

$$\begin{aligned}
& s(t(y_1, y_2), t(y_3, y_4)) \\
=_{\mathbb{U}} & \{ \text{Substitution} \} \\
& s(x_0, t(y_3, y_4))[t(y_1, y_2)/x_0] \\
=_{\mathbb{U}} & \{ \text{Equation (5.26) from Theorem 5.37} \} \\
& t(s(x_0, y_3), s(x_0, y_4))[t(y_1, y_2)/x_0] \\
=_{\mathbb{U}} & \{ \text{Substitution} \} \\
& t(s(t(y_1, y_2), y_3), s(t(y_1, y_2), y_4)) \\
=_{\mathbb{U}} & \{ \text{Equation (5.25) from Theorem 5.37} \} \\
& t(t(s(y_1, y_3), s(y_2, y_3)), t(s(y_1, y_4), s(y_2, y_4))). \tag{5.44}
\end{aligned}$$

Of course, both computations are equally valid, so the terms in Equations (5.43) and (5.44) must be equal:

$$\begin{aligned}
& t(t(s(y_1, y_3), s(y_1, y_4)), t(s(y_2, y_3), s(y_2, y_4))) \\
=_{\mathbb{U}} & t(t(s(y_1, y_3), s(y_2, y_3)), t(s(y_1, y_4), s(y_2, y_4))).
\end{aligned}$$

Since these are two separated terms that are equal, we can apply the essential uniqueness property, stating that there exist functions:

$$\begin{aligned}
f & : \{x_1, x_2, x_3, x_4\} \rightarrow Z \\
f' & : \{x_5, x_6, x_7, x_8\} \rightarrow Z,
\end{aligned}$$

such that:

- Equality in \mathbb{T} :

$$\begin{aligned}
& t(t(f(x_1), f(x_2)), t(f(x_3), f(x_4))) \\
=_{\mathbb{T}} & t(t(f'(x_5), f'(x_6)), t(f'(x_7), f'(x_8))).
\end{aligned}$$

- $f(x_i) = f'(x_j)$ iff the \mathbb{S} -terms substituted for x_i and x_j in Equations (5.43) and (5.44) are equal in \mathbb{S} .

From the second part of essential uniqueness we get that:

$$\begin{aligned}
f(x_1) & = f'(x_5) & f(x_3) & = f'(x_6) \\
f(x_2) & = f'(x_7) & f(x_4) & = f'(x_8).
\end{aligned}$$

For readability of the next argument, set:

$$\begin{aligned} z_1 &= f(x_1) = f'(x_5) & z_3 &= f(x_3) = f'(x_6) \\ z_2 &= f(x_2) = f'(x_7) & z_4 &= f(x_4) = f'(x_8). \end{aligned}$$

Putting this in the equality in \mathbb{T} we found under the first bullet point yields:

$$t(t(z_1, z_2), t(z_3, z_4)) =_{\mathbb{T}} t(t(z_1, z_3), t(z_2, z_4)).$$

And so by property (T5)b:

$$\# \text{ var}(t(t(z_1, z_2), t(z_3, z_4))) \leq 3.$$

So there must be i, j such that $i \neq j$ and $z_i = z_j$. Suppose without loss of generality that $z_1 = z_2$. Then by essential uniqueness we must have that $s(y_1, y_3) =_{\mathbb{S}} s(y_1, y_4)$. But then we can reason:

$$\begin{aligned} & y_1 \\ =_{\mathbb{S}} & \{ e_s \text{ is a unit for } s \} \\ & s(y_1, e_s) \\ =_{\mathbb{S}} & \{ \text{substitution} \} \\ & s(y_1, y_3)[e_s/y_3] \\ =_{\mathbb{S}} & \{ s(y_1, y_3) = s(y_1, y_4) \} \\ & s(y_1, y_4)[e_s/y_3] \\ =_{\mathbb{S}} & \{ \text{substitution: no } y_3 \text{ in } s(y_1, y_4) \} \\ & s(y_1, y_4). \end{aligned}$$

We conclude that, by property (S2): $\{y_1\} \vdash s(y_1, y_4)$, and so we must have $y_4 = y_1$. Since these variables are assumed to be distinct, we have a contradiction. The same argument holds for any other i, j pair. Therefore, the existence of a composite theory leads to a contradiction. In other words, no such composite theory exists. \square

Example 5.43 (Resolving an Open Question). This finally settles the question of whether the list monad distributes over itself, posed repeatedly by Manes and Mulry [44, 45]. The theory of monoids satisfies all the conditions required of both theories in Theorem 5.42, and hence there is no distributive law for the list monad over itself.

Note that a distributive law for lists was claimed by King and Wadler [34], although it was subsequently shown to be incorrect by Jones and Duponcheel [32].

Remark 5.44. Although there is no distributive law for the list monad over itself, the functor LL does still carry a monad structure. We are very grateful to Bartek Klin for pointing this out to us. The monad structure on LL can be described as follows:

- There is a distributive law for the list monad over the non-empty list monad $L \circ L^+ \Rightarrow L^+ \circ L$ [44].
- There is a distributive law for the resulting monad over the maybe monad $(L^+L) \circ (-)_\perp \Rightarrow (-)_\perp \circ (L^+L)$, derived from general principles [44].
- The resulting functor $(-)_\perp \circ (L^+ \circ L)$ is isomorphic to $L \circ L$, and carries a monad structure. Hence $L \circ L$ carries a monad structure, but not one that can be derived from a distributive law $L \circ L \Rightarrow L \circ L$.

Non-Example 5.45 (Multiset Monad). The multiset monad is closely related to the list monad, with an algebraic theory having just one extra equation compared to the list monad: commutativity. Because of this equation, the theory does not have property (T5)b. As we have seen in Example 5.41, there is a unique distributive law for the multiset monad over itself.

5.4.3 Yet Another No-Go Theorem Caused by Idempotence

In Section 5.3 we saw a no-go theorem that had an idempotent term on one side, and a unital one on the other: Theorem 5.28. We will now see a second theorem of this type. Adding idempotence of the binary to the assumptions for \mathbb{S} yields yet another no-go theorem.

Theorem 5.46 (No-Go Theorem: Idempotence and Units). *Let \mathbb{S} and \mathbb{T} be algebraic theories satisfying (S1), (S2), (S4) and (T2), (T3), (T4) respectively. Assume furthermore that there are terms:*

$$2 \vdash_{\mathbb{S}} s \quad \text{and} \quad 2 \vdash_{\mathbb{T}} t,$$

satisfying (S5)a, (S5)b and (T5)a respectively. Then there exists no composite theory of \mathbb{T} after \mathbb{S} .

Proof. Suppose such a composite theory \mathbb{U} exists. Then we have:

$$\begin{aligned}
& t(y_1, y_2) \\
=_{\mathbb{U}} & \{ \text{(S5)b: } s \text{ is idempotent} \} \\
& s(t(y_1, y_2), t(y_1, y_2)) \\
=_{\mathbb{U}} & \{ \text{Substitution} \} \\
& s(t(y_1, y_2), x_0)[t(y_1, y_2)/x_0] \\
=_{\mathbb{U}} & \{ \text{Equation (5.25) from Theorem 5.37} \} \\
& t(s(y_1, x_0), s(y_2, x_0))[t(y_1, y_2)/x_0] \\
=_{\mathbb{U}} & \{ \text{Substitution} \} \\
& t(s(y_1, t(y_1, y_2)), s(y_2, t(y_1, y_2))) \\
=_{\mathbb{U}} & \{ \text{Equation (5.26) from Theorem 5.37} \} \\
& t(t(s(y_1, y_1), s(y_1, y_2)), t(s(y_2, y_1), s(y_2, y_2))) \\
=_{\mathbb{U}} & \{ \text{(S5)b: } s \text{ is idempotent} \} \\
& t(t(y_1, s(y_1, y_2)), t(s(y_2, y_1), y_2)).
\end{aligned}$$

So from the essential uniqueness property, we may conclude that there are functions $f : \{y_1, y_2\} \mapsto Z$, $f' : \{y'_1, y'_2, y'_3, y'_4\} \mapsto Z$ such that:

$$t(f(y_1), f(y_2)) =_{\mathbb{T}} t(t(f'(y'_1), f'(y'_2)), t(f'(y'_3), f'(y'_4))),$$

and $f(y_i) = f'(y'_j)$ if and only if the \mathbb{S} -terms substituted for y_i and y'_j in $t(y_1, y_2)$ and $t(t(y_1, s(y_1, y_2)), t(s(y_2, y_1), y_2))$ are equal. From this we immediately get:

$$\begin{aligned}
f(y_1) &= f'(y'_1) \\
f(y_2) &= f'(y'_4).
\end{aligned}$$

We know from essential uniqueness that $f(y_1) \neq f(y_2)$. We show that $\{f'(y'_2), f'(y'_3)\} \subseteq \{f(y_1), f(y_2)\}$. Since we have:

$$t(f(y_1), f(y_2)) =_{\mathbb{T}} t(t(f'(y'_1), f'(y'_2)), t(f'(y'_3), f'(y'_4))),$$

we also have:

$$\begin{aligned}
& t(f(y_1), f(y_2))[e_t/f(y_1), e_t/f(y_2)] \\
& =_{\mathbb{T}} t(t(f'(y'_1), f'(y'_2)), t(f'(y'_3), f'(y'_4)))[e_t/f(y_1), e_t/f(y_2)] \\
\Rightarrow & \{ \text{Substitution, and } f(y_1) = f'(y'_1), f(y_2) = f'(y'_4) \} \\
& t(e_t, e_t) =_{\mathbb{T}} t(t(e_t, f'(y'_2)), t(f'(y'_3), e_t))[e_t/f(y_1), e_t/f(y_2)] \\
\Rightarrow & \{ (\text{T5})\text{a: } e_t \text{ is the unit of } t \} \\
& e_t =_{\mathbb{T}} t(f'(y'_2), f'(y'_3))[e_t/f(y_1), e_t/f(y_2)].
\end{aligned}$$

So by (T2), $\text{var}(t(f'(y'_2), f'(y'_3))[e_t/f(y_1), e_t/f(y_2)]) = \emptyset$. We must have:

$$\{f'(y'_2), f'(y'_3)\} \subseteq \{f(y_1), f(y_2)\}.$$

But then, by the second part of the essential uniqueness property:

$$s(y_1, y_2) =_{\mathbb{S}} y_1 \quad \text{or} \quad s(y_1, y_2) =_{\mathbb{S}} y_2.$$

Both contradict (S2). Therefore, the composite theory \mathbb{U} cannot exist. \square

Example 5.47 (Powerset Monad Again). The theory of join semilattices satisfies all the axioms required of both theories in Theorem 5.46. Therefore, there is no distributive law for the powerset monad over itself. This was already shown by Klin and Salamanca [35] using similar methods as in Section 5.3. Theorem 5.46 gives a second, independent proof of this fact.

Remark 5.48. Theorems 5.46 and 5.28 both require an idempotent term in theory \mathbb{S} , and a unital term in theory \mathbb{T} , to preclude a composite theory of \mathbb{T} after \mathbb{S} . However, these theorems are neither equivalent, nor does one imply the other. Theorem 5.28 applies only if the unital term in \mathbb{T} is commutative, whereas Theorem 5.46 allows this term to be non-commutative. Conversely, Theorem 5.46 requires the idempotent term in \mathbb{S} to be unital, where Theorem 5.28 does not have this restriction.

Non-Example 5.49 (Multiset Monad: The Sweet Spot). We come back to the multiset monad. In Non-Example 5.45 we saw that the algebraic theory presenting the multiset monad had one extra equation compared to the theory for the list monad: commutativity. Because of this equation, property (T5)b did not hold, and therefore Theorem 5.42 did not apply.

There is a similar relation between the multiset monad and the powerset monad. Compared to the powerset monad, the theory presenting the multiset monad *lacks*

just one equation: idempotence, which is exactly what property (S5)b requires. The lack of this equation in the theory for the multiset monad therefore means that Theorem 5.46 does not apply to multiset either. So multiset holds a sort of ‘sweet spot’ in between the two no-go theorems, where a distributive law $M \circ M \Rightarrow M \circ M$ still can and does exist.

5.5 A Final Generalisation: Stable Universal Sets

To broaden the range of applicability of the theorems presented in this chapter we can make one more generalisation. Instead of considering the entire set of terms, we may restrict to a special set of terms which we call a *stable universal set*. These sets are defined as follows:

Definition 5.50. For an algebraic theory \mathbb{T} , we say that a set of terms \mathcal{T} is:

- **Universal** if every term is provably equal to a term in \mathcal{T} .
- **Stable** if \mathcal{T} is closed under substitution of variables for variables.

Example 5.51. Some examples of universal and stable sets:

- [1] For any theory, the set of all terms is a stable universal set.
- [2] For the theory of real vector spaces, every term is equal to a term in which scaling by the zero element does not appear. Terms that do not contain the scale by zero operation are clearly also stable under variable renaming. Therefore the terms not containing the scale by zero operation are a stable universal set.
- [3] In the theory of groups, every term is equal to a term in which no subterm and its inverse are ‘adjacent’, so not: $x * x^{-1}$. This set is therefore universal. It is not stable, as variable renaming may introduce a subterm adjacent to its inverse: $x * y^{-1}[x/y] = x * x^{-1}$.

All global properties that we require in the various theorems in Chapter 5 can be restricted to a stable universal set of terms. For example, instead of requiring: “for any term t and variable x , $\Gamma \vdash t = x$ implies $\{x\} \vdash t$ ”, we can ask: “for any stable universal set of terms \mathcal{T} , if $t \in \mathcal{T}$ then $\Gamma \vdash t = x$ implies $\{x\} \vdash t$ ”.

We return to Example 5.22, where we used a non-standard presentation of the distribution monad with binary operations $+^p$ with p in the open interval $(0, 1)$ (see Example 2.32). We can use the standard presentation of the distribution monad if we restrict to stable universal sets.

Example 5.52 (Powerset and Distribution Monads again). We can consider the distribution monad to be presented by binary operations $+^p$ with p in the *closed* interval $[0, 1]$, and in fact this is the standard formulation. In this case, Theorem 5.20 can still be directly applied, without having to move to the more parsimonious presentation. We simply note that the terms not involving the operations $+^1$ and $+^0$ form a stable universal set satisfying the required axioms for Theorem 5.20.

Chapter 6

The Boom Hierarchy: a Case Study for Distributive Laws

We now pursue a detailed investigation of when distributive laws exist between some natural families of monads. To do so, we shall combine the techniques developed in earlier sections with results from the wider literature. Our objectives are to illustrate that the absence of distributive laws is not at all unusual, to document many useful examples, and to develop some intuitions via concrete applications.

We shall begin with the Boom hierarchy, a small family of monads considered in the functional programming literature [48]. Later, to increase our available data points, we will expand the original Boom hierarchy to include more exotic data structures. Similar expansions of the Boom hierarchy have been studied by Uustalu [59].

The Boom hierarchy is a simple family of four monads, providing a pleasing connection between commonly used data structures and natural algebraic axioms. The hierarchy consists of the tree, list, multiset, and powerset monads. Each of these monads has the same signature, consisting of a constant and a binary operation. If the only axiom is the unitality axiom, the resulting monad is the binary tree monad. Adding associativity yields the list monad. Further adding commutativity yields the multiset monad, and finally adding idempotence results in the finite powerset monad, as shown in Table 6.1.

Remark 6.1. The Boom hierarchy is named after the Dutch Computer Scientist Hendrik Boom. The fact that ‘Boom’ also means ‘tree’ in Dutch is not entirely coincidental. Allegedly, the name was coined by Peter Grogono in a meeting with Stephen Spackman and Hendrik Boom. Spackman was a MSc student co-supervised by Grogono and Boom, working on this hierarchy of data structures. When Grogono suggested the name for the hierarchy, Boom’s response was “What, because it is about

trees?”. The name has stuck ever since [57]. Lambert Meertens is the first to mention this hierarchy in the literature [48], citing an unpublished working paper by Boom [8].

Table 6.1: The Boom hierarchy

theory	unit	associative	commutative	idempotent
tree	✓	×	×	×
list	✓	✓	×	×
multiset	✓	✓	✓	×
powerset	✓	✓	✓	✓

Studying the patterns of distributive laws in the Boom hierarchy provided some of the original inspiration for the abstract no-go theorems presented in earlier sections. We now use the same hierarchy, and generalisations of it, to demonstrate both their scope and limitations, and their relationship to the existing positive results we are aware of in the literature.

6.1 The Original Boom Hierarchy

For the original Boom hierarchy we have complete knowledge of possible compositions via distributive laws. An overview is presented in Table 6.2 below.

The negative result for $P \circ P \Rightarrow P \circ P$ was already shown by [35], and can also be recovered from both Theorems 5.20 and 5.46. The other negative results follow from either Theorem 5.42 or Theorem 5.46. Sometimes both theorems can be applied, for example to preclude a distributive law of type $P \circ L \Rightarrow L \circ P$.

The positive results are due to Manes and Mulry. They show that any monad with only linear equations in its presentation distributes over any commutative monad¹, via the times over plus distributivity [44, Theorem 4.3.4]. The multiset and powerset monads are both commutative, and the theories of the tree, list and multiset monads all have solely linear equations. This yields the six distributive laws indicated in the table. Theorem 5.37 proves that these distributive laws are in fact the only possible distributive laws for these monads.

¹A commutative monad is a strong monad for which the two possible double strengths coincide [36]. Algebraically, this means that all operations in the signature commute with one another. This is quite different from the algebraic property of commutativity that we consider in the Boom hierarchy.

Table 6.2: Possible compositions in the Boom hierarchy, with distributive laws of type: $\text{row} \circ \text{column} \Rightarrow \text{column} \circ \text{row}$.

	tree	list	multiset	powerset
tree	×	×	✓	✓
list	×	×	✓	✓
multiset	×	×	✓	✓
powerset	×	×	×	×

In this small sample, Manes and Mulry’s theorem is powerful enough to yield all the possible positive results. However, Table 6.2 is too small to draw general conclusions. To extract more information, we will expand the Boom hierarchy.

6.2 The Extended Boom Hierarchy

The original Boom hierarchy discussed in Section 6.1 consists of a small number of well motivated data structures. Unfortunately, this small size means that it provides limited scope for identifying patterns in distributive law phenomena. To address this, we now consider an extended hierarchy in which all possible combinations of the original algebraic axioms appear, rather than the axioms being gradually added in a fixed order. This yields a total of eight different monads: tree, idempotent tree, commutative tree (mobile), associative tree (list), idempotent and commutative tree, idempotent and associative tree (square-free list), associative and commutative tree (multiset), idempotent commutative and associative tree (powerset). If we additionally consider the non-empty versions of these monads, corresponding algebraically to removing the constant from the signature, the number of monads doubles to sixteen. Of course, some of these monads are less natural from a functional programming perspective, but they provide a convenient range of candidates for investigation.

An overview of these monads is given in Table 6.3 below. We have named the monads according to the axioms their theories satisfy: U (unitality), A (associativity), C (commutativity), I (idempotence). For example, multisets are associative and commutative trees with units, so they are denoted UAC in the table, whereas their non-empty version, which has no unit, is called AC . Note that this convention is unambiguous as we always impose the unitality axiom when the unit constant is present.

Table 6.3: The extended Boom hierarchy

theory	unital	associative	commutative	idempotent
non-empty tree	×	×	×	×
I	×	×	×	✓
C	×	×	✓	×
CI	×	×	✓	✓
A	×	✓	×	×
AI	×	✓	×	✓
AC	×	✓	✓	×
ACI	×	✓	✓	✓
U (tree)	✓	×	×	×
UI	✓	×	×	✓
UC (mobile)	✓	×	✓	×
UCI	✓	×	✓	✓
UA (list)	✓	✓	×	×
UAI (square-free list)	✓	✓	×	✓
UAC (multiset)	✓	✓	✓	×
UACI (powerset)	✓	✓	✓	✓

Within this extended Boom hierarchy, there are a total of 256 monad compositions to consider. Some distributive laws arise via Manes and Mulry’s positive general theorems [44, Theorem 4.3.4] [45, Example 4.9]. Other combinations are known to have a distributive law because an ad-hoc one has been found, for example for the non-empty list monad over itself [44, 45]. A large number of the combinations are proven impossible by theorems from this paper. Our current knowledge about the existence of distributive laws for this extended Boom hierarchy is given in Table 6.4.

Out of the 256 pairs of monads in Table 6.4:

- The 41 labelled with ✓ have a distributive law between them.
- The 122 labelled with × do not have a distributive law between them.
- The remaining 93 pairs labelled with ? remain to be understood.

That is, almost half of the combinations of monads from the extended Boom hierarchy do not have a distributive law between them. The bottom right corner of Table 6.4 is especially striking. Every possible combination is understood, and 56 out of 64 combinations do not have a distributive law. This provides further evidence that we should not assume “most” monads will compose via suitable distributive laws.

Table 6.4: Distributive laws in the extended Boom hierarchy,
with laws of type: row \circ column \Rightarrow column \circ row.

	\emptyset	I	C	CI	A	AI	AC	ACI	U	UI	UC	UCI	UA	UAI	UAC	UACI
\emptyset	✓	?	?	?	?	?	✓	✓	?	?	?	?	?	?	✓	✓
I	?	×	?	×	?	×	?	×	?	×	×	×	?	×	×	×
C	✓	?	?	?	?	?	✓	✓	?	?	?	?	?	?	✓	✓
CI	?	×	?	×	?	×	?	×	?	×	×	×	?	×	×	×
A	✓	?	?	?	✓	?	✓	✓	?	?	?	?	?	?	✓	✓
AI	?	×	?	×	?	×	?	×	?	×	×	×	?	×	×	×
AC	✓	?	?	?	?	?	✓	✓	?	?	?	?	?	?	✓	✓
ACI	?	×	?	×	?	×	?	×	?	×	×	×	?	×	×	×
U	✓	?	?	?	?	?	✓	✓	×	×	×	×	×	×	✓	✓
UI	?	×	?	×	?	×	?	×	×	×	×	×	×	×	×	×
UC	✓	?	?	?	?	?	✓	✓	×	×	×	×	×	×	✓	✓
UCI	?	×	?	×	?	×	?	×	×	×	×	×	×	×	×	×
UA	✓	?	?	?	?	?	✓	✓	×	×	×	×	×	×	✓	✓
UAI	?	×	?	×	?	×	?	×	×	×	×	×	×	×	×	×
UAC	✓	?	?	?	?	?	✓	✓	×	×	×	×	×	×	✓	✓
UACI	?	×	?	×	?	×	?	×	×	×	×	×	×	×	×	×

An unsurprising pattern that emerges from Table 6.4 is that the axioms of idempotence and units are ‘bad’ properties for monad compositions. Since all of our no-go theorems require at least one of these properties to hold, this observation does not lead to any new insights.

In the positive results, the most apparent patterns are the columns \emptyset , AC , ACI , UAC , and $UACI$. These are precisely the cases captured by Manes and Mulry.

For the remaining open cases, we cannot make any meaningful predictions. Our current techniques in no-go theorems require some way of bringing a term down to a variable, either via idempotence or via units. Whether this is the key property that prevents the existence of distributive laws remains an open question. On the other hand, all general positive results rely on one of the monads being commutative. The ad-hoc distributive law of the non-empty list monad over itself clearly indicates that commutativity is not a necessary condition for distributive laws to exist.

One thing is certain: to systematically fill in the gaps in Table 6.4 we will need additional ideas, supporting either further positive, or negative, theorems. As such, analysing these hierarchies highlights directions which will deepen our understanding of distributive laws.

6.3 Iterated Compositions

Another way to extend the original Boom hierarchy is to add the monads resulting from the six distributive laws appearing in Table 6.2. In order to study these additional monads, we first give concrete presentations for each of them:

Lemma 6.2. *The presentations of the composite monads MT , ML , MM , PT , PL , PM are as follows:*

- *The composite monad MT is presented by the following theory:*

- *Signature:* $\Sigma^{MT} = \{0^{(0)}, 1^{(0)}, +^{(2)}, *^{(2)}\}$.

- *Equations:* 0 is the unit of $+$, $+$ is associative and commutative, 1 is the unit of $*$, 0 is a multiplicative zero:

$$0 * x = 0 \tag{6.1}$$

$$x * 0 = 0, \tag{6.2}$$

and $$ distributes over $+$ from both left and right:*

$$x * (y + z) = (x * y) + (x * z) \tag{6.3}$$

$$(x + y) * z = (x * z) + (y * z). \tag{6.4}$$

- *ML has the same signature and equations as MT , with the additional equation that $*$ is associative.*
- *MM also has the same signature and equations as MT , with $*$ additionally being associative and commutative.*
- *PT , PL , and PM have the same signatures and equations as MT , ML , and MM respectively, with one additional equation: $+$ is idempotent.*

Proof. We prove only that the given presentation for the monad MT is correct, the others follow similarly. From Corollary 3.10, we know that the composite monad MT has presentation:

- *Signature:* $\Sigma^{MT} = \Sigma^M \uplus \Sigma^T = \{0^{(0)}, 1^{(0)}, +^{(2)}, *^{(2)}\}$.

- *Equations:* $E^{MT} = E^M \cup E^T \cup E^\lambda = \{0 \text{ is the unit of } +, + \text{ is associative and commutative}\} \cup \{1 \text{ is the unit of } *\} \cup \{s[t_x/x] =_{\mathbb{M}\mathbb{T}} t[s_y/y] \mid s, s_y \text{ terms in } \mathbb{M} \text{ } t, t_x \text{ terms in } \mathbb{T}\}$.

So all we need to show is that Equations (6.1), (6.2), (6.3), and (6.4) are enough to prove all equations in E^λ , that is, all equations of form $s[t_x/x] =_{\text{MT}} t[s_y/y]$.

To prove that all equations in E^λ are provable from the four given axioms, it is enough to show that each term of form $s[t_x/x]$ is separable via the given axioms. Essential uniqueness then does the rest: Suppose that both $s[t_x/x] =_{\text{MT}} t[s_y/y]$ and $s[t_x/x] =_{\text{MT}} t'[s'_y/y']$ are in E^λ , and the first of these equations is provable using Equations (6.1), (6.2), (6.3), and (6.4). Then by transitivity of $=_{\text{MT}}$ we know $t'[s'_y/y'] =_{\text{MT}} t[s_y/y]$. Since this is an equality between two separated terms, essential uniqueness gives us that it is provable using just the axioms in E^M and E^T . So once we have derived one equation in E^λ involving a particular term $s[t_x/x]$, we automatically gain all equations in E^λ involving this term.

To prove that every term of form $s[t_x/x]$ is separable using just the axioms Equations (6.1), (6.2), (6.3), and (6.4), we use induction on the term complexity of s :

Base cases: s is a constant or a variable. In these cases $s[t_x/x]$ is already separated. Induction step: Suppose that $s = s_1 * s_2$, and assume that $s_1[t_x/x]$ and $s_2[t_x/x]$ are both separable using the four equations described above. Then we need to show that $s[t_x/x]$ is separable. Let $t'_1[s'_y/y']$ and $t'_2[s'_y/y']$ be the terms resulting from separating s_1 and s_2 respectively. We need induction on both t'_1 and t'_2 :

- If t'_1 is a constant, $t'_1 = 0$, then by Equation (6.1): $s[t_x/x] = 0 * s_2 = 0$, and hence $s[t_x/x]$ is separable.
- If t'_1 is a variable, $t'_1 = x_1$, we use induction t'_2 :
 - If t'_2 is a constant, then by Equation (6.2): $s[t_x/x] = s_1 * 0 = 0$, and hence $s[t_x/x]$ is separable.
 - If t'_2 is a variable, $t'_2 = x_2$, then $s[t_x/x] = x_1 * x_2$, which is a separated term.
 - If t'_2 is a term of form $t'_3 + t'_4$, and we assume (induction hypothesis) that $x_1 * t'_3$ is separable and $x_1 * t'_4$ is separable, then $s[t_x/x] = x_1 * (t'_3 + t'_4)$. By Equation (6.3), we can write:

$$\begin{aligned} & s[t_x/x] \\ &= x_1 * (t'_3 + t'_4) \\ &= (x_1 * t'_3) + (x_1 * t'_4). \end{aligned}$$

Since both $(x_1 * t'_3)$ and $(x_1 * t'_4)$ are separable, this shows that $s[t_x/x]$ is separable.

- If t'_1 is a term of form $t'_5 + t'_6$, we may assume (induction hypothesis) that $t'_5 * t'_2$ and $t'_6 * t'_2$ are separable. By Equation (6.4), we know:

$$\begin{aligned}
& s[t_x/x] \\
&= (t'_5 + t'_6) * t'_2 \\
&= (t'_5 * t'_2) + (t'_6 * t'_2).
\end{aligned}$$

Since both $(t'_5 * t'_2)$ and $(t'_6 * t'_2)$ are separable, this shows that $s[t_x/x]$ is separable.

We conclude that the given presentation does indeed present the monad MT . \square

Checking these presentations against the various no-go theorems presented in this paper yields a new table of possible compositions, displayed in Table 6.5. Other than the six combinations we already discovered in the original Boom hierarchy, we find no new combinations of monads that compose via a distributive law. The results shown in the columns of the composite monads MT, ML, MM, PT, PL, PM are covered by Theorem 5.4, while Theorem 5.10 covers the rows containing these monads.

Table 6.5: Possible compositions in the Boom hierarchy, with distributive laws of type: row \circ column \Rightarrow column \circ row.

	tree	list	multiset	powerset	MT	ML	MM	PT	PL	PM
tree	×	×	✓	✓	×	×	×	×	×	×
list	×	×	✓	✓	×	×	×	×	×	×
multiset	×	×	✓	✓	×	×	×	×	×	×
powerset	×	×	×	×	×	×	×	×	×	×
MT	×	×	×	×	×	×	×	×	×	×
ML	×	×	×	×	×	×	×	×	×	×
MM	×	×	×	×	×	×	×	×	×	×
PT	×	×	×	×	×	×	×	×	×	×
PL	×	×	×	×	×	×	×	×	×	×
PM	×	×	×	×	×	×	×	×	×	×

6.4 Self-Distribution

For our final study of the Boom hierarchy we zoom in on a particular part of Table 6.4, namely that of self-distribution. In Chapter 4 we observed that only idempotent monads distribute over themselves via the identity distributive law, but there are plenty of monads that self-distribute in a non-trivial way. The multiset monad is probably

the best known example; it self-distributes via the times over plus distributivity. Self-distribution of monads has been a powerful drive in the discovery of no-go theorems: Klin and Salamanca focussed on distributing the powerset monad over itself [35], and my own early research concerned mainly the self-distribution of the probability distribution monad and the list monad.

Self-distribution is not always a good starting point. When the properties of two monads/theories under study are the same, it is easy to lose track of which monad's/theory's properties are applied at which point in a proof. This can make a proof of a specific counterexample harder to generalise: in the proofs of this thesis, the axioms for each of the two theories are quite different. Such differences are hard to spot when starting out from a symmetric situation.

The main power of self-distributions seems to be that they point to questions to be solved. Self-distributions in the Boom hierarchy in particular have been an inspiration before, and they have a final question for us left. Let us consider self-distributions of the extended Boom hierarchy:

\emptyset	I	C	CI	A	AI	AC	ACI	U	UI	UC	UCI	UA	UAI	UAC	UACI	
✓	×	?	×	✓	×	✓	×	×	×	×	×	×	×	×	✓	×

To get a better picture of the pattern, we visualise this data in a four dimensional cube. Starting from the top-left-back corner of the outer cube, each direction represents adding a certain axiom: going right adds associativity, going to the front adds commutativity, going down adds units, and going to the inner cube adds idempotence. Monads that self-distribute are printed in green, monads that do not are printed in red, and monads for which it is currently unknown whether they self-distribute or not are identified with a '?'.

From the theorems of this thesis, we know that idempotence is a ‘dangerous’ equation, which is reflected in the impossibility to distribute any of the monads with idempotence over themselves: the inner cube is completely red. Unitality is another dangerous equation, and indeed most of the monads in this hierarchy with units do not distribute over themselves. But curiously the monad UAC , better known as the multiset monad, *does* distribute over itself, breaking the pattern. We have observed before that the multiset monad seems to walk the fine line between several no-go theorems.

All monads without units or idempotence seem to distribute over themselves. However, there is one exception: C , commutative trees or *mobiles*. It is currently unknown if this monad distributes over itself. The monad C is not as commonly used as powerset and list are, so on its own, the question of whether C distributes over itself is not hugely interesting. However, looking at the patterns in the hypercube, I believe that it could provide the answer to a much bigger question:

- Are equations such as idempotence and units, where a more complicated term is reduced to a variable, necessary conditions for no-go theorems?

That is, do two theories automatically distribute over one another if neither theory has a way to reduce a more complicated term to a variable? We will return to this question in Section 7.4.

If C does not distribute over itself, then it would be the first monad known to have this property without having either unitality or idempotence as axioms. The proof would give us valuable insight in the behaviour of distributive laws, perhaps even leading to a new method for proving no-go theorems.

If, on the other hand, C does distribute over itself, then it would strengthen our current belief in the importance of the unitality and idempotence axioms. This would be the less dramatic, but more realistic, outcome.

Either way, determining whether C distributes over itself will give us another piece of information about when distributive laws do and do not exist between two monads.

Chapter 7

The Algebraic Method: a Reflection on our Techniques

The main focus of this thesis has been the application of the algebraic method in proofs of no-go theorems for distributive laws. We have proven many theorems using this method, gaining previously inaccessible insights into the behaviour of distributive laws. In this chapter, we study the method itself. We will compare it to the more standard categorical approach, and identify its strengths and its limitations.

7.1 The Algebraic Method: Techniques

Our algebraic method starts from the concept of a composite theory, the algebraic equivalent of a distributive law. The major advantage of working on the algebraic side is that it allows us to see and manipulate expressions on term level, whereas the more traditional categorical approach only gives access to equivalence classes of terms. We use this concreteness in our tactics for finding no-go theorems, which are all proven by way of contradiction: we assume that a composite theory exists, then we find a specific term and derive equations from it that are inconsistent with this assumption. The proofs in Chapter 5 all use the same techniques in roughly the same order to get to this contradiction. In this section, we summarise these techniques and explain them in detail. During this analysis, we also explain how we arrive at the specific axioms in our theorems, some of which may seem unusual to readers unfamiliar with this type of reasoning.

Our no-go theorems have mostly been inspired by concrete examples: Theorems 5.10 and 5.14 were inspired by the Abelian group monad and the list monad, Theorem 5.20 was inspired by the probability distribution and powerset monads, and Theorem 5.42 was again inspired by the list monad. In constructing a general no-go

theorem, we generally start with two concrete theories, and keep track of which of their properties we use in the proof. By then including these properties in the axioms of the theorem, the theorem is transformed from a simple counterexample to a general no-go theorem that holds for any monad satisfying the stated properties. We will therefore use two concrete example theories to illustrate our techniques in proving no-go theorems. These theories are used specifically as an illustration of the techniques; we do not derive a full no-go theorem for them.

Define \mathbb{S} to be the theory consisting of an idempotent binary operator and \mathbb{T} the theory of a unital binary operator with a constant as unit:

$$\begin{aligned} \Sigma^{\mathbb{S}} &= \{s^{(2)}\} & \Sigma^{\mathbb{T}} &= \{e^{(0)}, t^{(2)}\} \\ E^{\mathbb{S}} &= \{s(x, x) = x\} & E^{\mathbb{T}} &= \{t(e, x) = x = t(x, e)\} \end{aligned}$$

Proving a no-go theorem about the compositionality of these two theories in the order \mathbb{T} after \mathbb{S} would typically involve the following steps:

- [1] We assume that a composite theory of \mathbb{T} after \mathbb{S} exists, and call it \mathbb{U} . We study this composite theory in the hope to either derive a contradiction or prove that the theory is the trivial (inconsistent) theory in which all terms are equal to each other, which then contradicts Proposition 3.5.
- [2] To get started, we choose a particular term. Finding a suitable term involves some creativity, but there are two main guidelines:
 - It should be a non-separated term ('out of order'), so in the example it should be a term with t or e inside an s . By the separation axiom of composite theories, we then know that this term is equal to an as yet unknown separated term. Much of the proof effort will be to discover properties of this separated term.
 - It should be a simple term, but complicated enough to incorporate useful properties of the two theories. In our example, both theories have binaries with special properties, so these binaries should appear in the term, but only once or twice, and certainly not nested several times. Incorporating the constant could also be useful.

Based on these criteria, suitable terms for our example theories could be:

$$s(t(a, b), t(c, d)) \quad \text{or} \quad s(e, t(a, b)).$$

For the rest of the example, we pick the first of these two. We then know that this term is equal to some separated term of form $t'[s'_x/x]$:

$$s(t(a, b), t(c, d)) =_{\mathbb{U}} t'[s'_x/x].$$

- [3] We then use substitutions on our chosen term to gradually mould it into a separated term. In case of the term $s(t(a, b), t(c, d))$, the substitution $c \mapsto a, d \mapsto b$ is useful. This substitution, together with idempotence of s , yields:

$$\begin{aligned} s(t(a, b), t(c, d))[a/c, b/d] &=_{\mathbb{U}} s(t(a, b), t(a, b)) \\ &=_{\mathbb{U}} t(a, b). \end{aligned}$$

The term $t(a, b)$ is indeed separated. The usefulness of having manipulated our chosen term into a separated term becomes clear in the next step.

- [4] We use essential uniqueness. We now have a chain of equations of the form “known separated term $=_{\mathbb{U}}$ chosen term under certain substitutions $=_{\mathbb{U}}$ unknown separated term under the same substitutions”. In our example:

$$t(a, b) =_{\mathbb{U}} s(t(a, b), t(c, d))[a/c, b/d] =_{\mathbb{U}} t'[s'_x[a/c, b/d]/x].$$

Applying essential uniqueness then gives us information about the unknown separated term. In our example, essential uniqueness gives us two substitutions, f_1, f_2 , such that:

$$t(a, b)[f_1] =_{\mathbb{T}} t'[f_2] \quad (\text{Proposition 3.4, 3a})$$

$$f_1(a) = f_1(b) \Leftrightarrow a =_{\mathbb{S}} b \quad (\text{Proposition 3.4, 3b})$$

$$f_2(x) = f_2(x') \Leftrightarrow s'_x =_{\mathbb{S}} s'_{x'} \quad (\text{Proposition 3.4, 3c})$$

$$f_1(a) = f_2(x) \Leftrightarrow a =_{\mathbb{S}} s'_x[a/c, b/d] \quad (\text{Proposition 3.4, 3d})$$

$$f_1(b) = f_2(x) \Leftrightarrow b =_{\mathbb{S}} s'_x[a/c, b/d]. \quad (\text{Proposition 3.4, 3d})$$

We immediately see that $f_1(a)$ cannot be equal to $f_1(b)$. We also gained possible information about the s'_x terms in the unknown separated term: if $f_1(a) = f_2(x)$ then we know $s'_x[a/c, b/d] =_{\mathbb{S}} a$, and if $f_1(b) = f_2(x)$, then we know $s'_x[a/c, b/d] =_{\mathbb{S}} b$. However, f_2 might not send any x to $f_1(a)$ or $f_1(b)$, so at this stage we cannot make any further conclusions.

- [5] We add assumptions to our theorem. These allow us to draw useful conclusions from the information we gained from essential uniqueness. The added assumptions should be properties of \mathbb{S} and/or \mathbb{T} . Assumptions come in two flavours:

- Algebraic properties, such as idempotence, commutativity, or unitality. These are properties we used earlier to manipulate our chosen term into a separated term.
- Variable management properties. These are less common properties to require, but turn out to be vital in our proofs. Some examples are: “if a term t is equal to the constant e , then t cannot have any variables”, or “if a term s' is equal to the binary s , then s' can have at most two variables”.

When reasoning about specific algebraic theories (or monads), assumptions of the second kind are rarely mentioned. However, noticing their use explicitly and adding all such properties that are used in a proof as assumptions to the theorem turns a no-go theorem from a specific theorem about the theories \mathbb{S} and \mathbb{T} into a general theorem, that holds for any pair of theories satisfying the final list of assumptions.

In our example, we may wish to add the following assumption about \mathbb{T} : “for any term t' in \mathbb{T} , if $t' =_{\mathbb{T}} t(a, b)$, then the only variables that can appear in t' are a and b ”. Since we know from essential uniqueness that $f_1(a) \neq f_1(b)$, we may use this assumption to conclude that the variables of $t'[f_2]$ must be either equal to $f_1(a)$ or $f_1(b)$. Therefore, for any variable x of t' , $f_2(x) = f_1(a)$ or $f_2(x) = f_1(b)$, and hence we can conclude from the previous step (essential uniqueness) that $s'_x[a/c, b/d] =_{\mathbb{S}} a$ or $s'_x[a/c, b/d] =_{\mathbb{S}} b$.

- [6] The proofs continue using this strategy, either by going back to the chosen term and executing a different substitution, or by making appropriate substitutions to other terms. Eventually, the conclusions we draw about terms give a contradiction, finishing the proof of the no-go theorem. For this example to become a finished no-go theorem, we need to add more assumptions and do a few more substitutions, see for instance Theorem 5.28.

7.2 Comparison to Categorical Methods

We compare the strategies from the categorical methods with our algebraic method. First, we translate the axioms of monads and distributive laws into algebra. Then we look at our algebraic methods from a categorical perspective, and at common categorical methods from an algebraic perspective.

7.2.1 Monad and Distributive Law Axioms Algebraically

We translate the axioms of monads and distributive laws into algebra.

Monads Algebraically

Recall that a monad is a triple consisting of a functor T , a unit natural transformation η and a multiplication natural transformation μ . Algebraically these can be interpreted as follows.

- The functor maps a set of variables X to the set TX of equivalence classes of all possible terms built from those variables.
- The unit η_X includes every variable $x \in X$ as a term in TX .
- The multiplication μ_X makes substitutions of terms for variables ‘legal’: a term with terms substituted for its variables $t[t_x/x]$ is still a term.

The monad axioms ensure that variables and substitutions behave in the expected way. To avoid needlessly complicated notation, we ignore equivalence classes, trusting that the reader can fill in the details if necessary.

$\mu \circ T\eta = Id_T$: $t[x/x] = t$. That is, a term t in which we substitute every variable with itself, yields just t itself.

$\mu \circ \eta T = Id_T$: $x[t/x] = t$. That is, a variable in which we substitute a term, yields exactly that term.

$\mu \circ T\mu = \mu \circ \mu T$: $t[t_x[t_y/y]/x] = t[t_x/x][t_y/y]$. That is, substitution is associative (assuming sensible naming of the variables appearing in t and all of the t_x).

Algebraically, these axioms are almost trivial. Yet they ensure that monads are well-behaved structures, which is vital for their applications.

Distributive Laws Algebraically

We have already seen the intimate connection between distributive laws and composite theories in Chapter 3. We now look at the axioms for distributive laws from an algebraic perspective.

The first thing to notice is that applying a distributive law is the categorical equivalent of separating a term:

$$\lambda(s[t_x/x]) = t'[s'_y/y].$$

Of course, there are equivalence classes involved, so in the notation from Chapter 3:

$$\lambda[s[[t_x]_{\mathbb{T}}/x]]_{\mathbb{S}} = [t'[[s'_y]_{\mathbb{S}}/y]]_{\mathbb{T}}.$$

We first consider the unit axioms of a distributive law. They are again trivial when seen from an algebraic perspective. We ignore equivalence classes, favouring a less cluttered notation.

$\lambda \circ \eta^S T = T \eta^S$: $x[t/x] = t[y/y]$, where on both sides of the equation the shown variables are interpreted as \mathbb{S} -terms. Since we know from above that $x[t/x] = t = t[y/y]$, this clearly must hold.

$\lambda \circ S \eta^T = \eta^T S$: $s[x/x] = y[s/y]$, similar to the first axiom, but with the roles of \mathbb{S} and \mathbb{T} reversed.

The multiplication axioms are where all the interesting action is. They are the categorical equivalent of essential uniqueness.

$\lambda \circ \mu^S T = T \mu^S \circ \lambda S \circ S \lambda$: Given a term of form $s[s_x[t_y/y]/x]$, this law states that it does not matter whether we view the term $s[s_x/x]$ as a single term s' and separate $s'[t_y/y]$ directly, or if we first separate each of the terms $s_x[t_y/y]$, resulting in terms $t'_x[s'_z/z]$, and then separate $s[t'_x/x][s'_z/z]$. Both methods yield the same term, up to equivalence.

$\lambda \circ S \mu^T = \mu^T S \circ T \lambda \circ \lambda T$: Given a term of form $s[t_x[t_y/y]/x]$, this law states that it does not matter whether we view the terms $t_x[t_y/y]$ as a single terms t'_x and separate $s[t'_x/x]$ directly, or if we first separate each of the terms $s[t_x/x]$, resulting in terms $t''[s'_z/z][t_y/y]$, and then separate $t''[s'_z/z][t_y/y]$. Both methods yield the same term, up to equivalence.

At first sight, these laws seem as trivial as the others. On the algebra side, separation is just an equality $=_{\mathbb{U}}$ between terms in a composite theory \mathbb{U} , so separating along two different paths is just a chain of equalities. Since equality is transitive, this will of course yield two terms equal to each other. However, on the categorical side, we are working with equivalence classes. These equivalence classes are not just equivalence classes of the free model monad U of the composite theory \mathbb{U} , they are equivalence classes of the monad TS , which consist of equivalence classes of \mathbb{T} -terms with equivalence classes of \mathbb{S} terms as variables. The equality that the multiplication axioms require is therefore an equality that must be provable using the axioms of

\mathbb{S} and \mathbb{T} alone. That is, it requires equality modulo (S, T) . This is exactly what essential uniqueness guarantees.

7.2.2 Algebraic Methods Categorically

Part of the beauty of using universal algebra comes from the limited number of options we have in algebraic reasoning. Recall from Figure 2.1 that the inference rules we can use are: reflexivity, symmetry, transitivity, substitution, congruence, and any axiom of the theories we are using. Axioms are specific to the theory and correspond directly to specific properties of the monads/categorical structure in question. The other methods are generally applicable. We will now look at how these methods are used in a categorical setting.

Reflexivity, Symmetry and Transitivity

The basic building blocks of any equational logic are the axioms of an equivalence relation. These axioms are considered so trivial that their use in proofs is rarely mentioned, and this thesis is no exception in that regard. Categorically, the uses of these axioms correspond to *diagram chases*. Any proof where a diagram is proved to commute by chaining several known commuting diagrams together, is just proving an equality using the axioms of reflexivity, symmetry and transitivity. Of course, the known commuting diagrams are often obtained from axioms or previously proven theorems/lemmas, but it is not uncommon for a diagram chase to explicitly include reflexivity.

Substitution

An important tool in algebraic reasoning is substitution. We used substitutions to manipulate terms, getting them into a specific form so that we can apply axioms or previous theorems on them. We will discuss two types of substitutions: variables-for-variables and more complicated terms-for-variables. Algebraically, substituting variables for variables is just a special case of substituting terms for variables, since every variable is a term. Categorically, however, there is a significant difference.

Variable-for-Variable Substitutions: Let us first consider variable-for-variable substitutions. If f is such a substitution, then f changes the underlying set of variables $\text{var}(t) = X$ of a term t to $\text{var}(t[f]) = Y$. We noticed previously that a monad T maps a set X to the set TX of equivalence classes of terms build out of the variables appearing in X . A variable for variable substitution $f : X \rightarrow Y$ is then executed

categorically by applying the monad to the function f , resulting in $Tf : TX \rightarrow TY$. However, in the categorical case, the variable substitution Tf works on equivalence classes. This is well-defined because of the algebraic axiom of substitution, which states that equality of terms is not affected by substitutions:

$$\frac{t =_{\mathbb{T}} t'}{t[f] =_{\mathbb{T}} t'[f]}$$

Term-for-Variable Substitutions: In a term-for-variable substitution, variables are substituted with terms, which themselves have variables. A term t with $\text{var}(t) = X$ is hence changed to have variables $\text{var}(t) = \mathcal{T}$, where \mathcal{T} is a set of terms, and each term in \mathcal{T} has variables in some set Y . The resulting term-of-terms is then interpreted as a single term t' , with variables $\text{var}(t') = Y$. Writing this out categorically, we see the type of a familiar map:

$$TX \mapsto TTY \mapsto TY.$$

It is the Kleisli-extension operator $(\cdot)^*$ used in the Kleisli formulation of monads, an equivalent definition of monads commonly used among functional programmers. Given a multiplication μ of a monad and a function $f : X \rightarrow TX$, the extension is defined by:

$$f^* = \mu \circ Tf.$$

This is exactly defining a term-for-variable substitution categorically. Again, the axiom of substitution ensures that this is well-defined on equivalence classes of terms.

Congruence

Congruences are what makes ‘substituting equals for equals’ possible. Its categorical use is most apparent in string-diagrammatic reasoning. Congruence allows us to replace part of a bigger diagram with a different diagram which we know is equal to that part. For instance, when applying one of the monad laws:

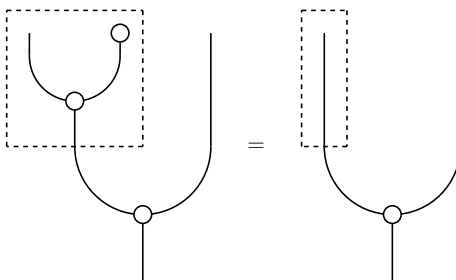

7.2.3 Categorical Methods Algebraically

Contrary to universal algebra, the categorical toolbox is vast. There are many axioms and theorems that are frequently applied, such as naturality, the Yoneda lemma, and universality, to name just a few. It is almost impossible to mention all methods available to the category theorist. We have already seen that diagram chasing is similar to equational reasoning in universal algebra. Here, we consider one other frequently used categorical method: naturality. This method is of particular interest because it is the main method used in the proof of Plotkin’s original counterexample, which showed that nondeterminism does not distribute over probability [60].

Naturality

Let $\{X_i \mid i \in I\}$ be a family of objects in a category \mathcal{C} , and $F, G : \mathcal{C} \rightarrow \mathcal{D}$ be two functors. Then a family of morphisms $\phi_{X_i} : FX_i \Rightarrow GX_i$, behaves ‘naturally’ when they commute with functions applied to the underlying objects X_i , as shown in the familiar naturality diagram below:

$$\begin{array}{ccc} FX_i & \xrightarrow{\phi_{X_i}} & GX_i \\ \downarrow Ff & & \downarrow Gf \\ FX_j & \xrightarrow{\phi_{X_j}} & GX_j \end{array}$$

When the functors are monads, and the objects X_i are sets, the objects FX_i can be understood algebraically as the set of terms build from variables $x \in X_i$, and as we saw in Section 7.2.2 above, the functions Ff and Gf can be interpreted as variable-for-variable substitutions. Naturality then says that the action of the morphism ϕ commutes with variable-for-variable substitutions.

7.3 Regarding the Scope of Theorems

Plotkin’s original proof, showing that non-determinism does not distribute over probability, uses only the naturality diagram and the unit axioms of a distributive law. The result therefore also holds for just the pointed endofunctors $\langle P, \eta^P \rangle$ and $\langle D, \eta^D \rangle$ instead of the full monads $\langle P, \eta^P, \mu^P \rangle$ and $\langle D, \eta^D, \mu^D \rangle$. The proofs by Klin and Salamanca also avoid the use of the multiplication axioms of distributive laws, which means their proofs apply to pointed endofunctors as well [35].

Categorically, it is trivial to derive the scope of a proof from the axioms that are used in the proof, as demonstrated in the following flowchart:

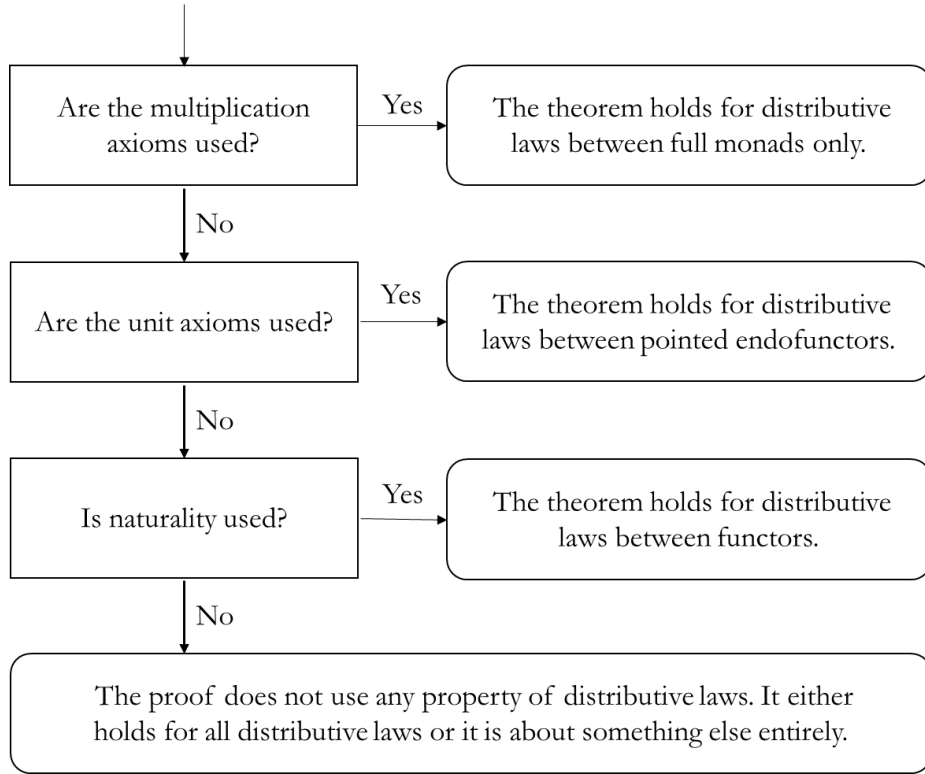

Algebraically, we have seen that many of the axioms of distributive laws are trivial, and so it is harder to spot where they are used in a proof. The most obvious difference is the type of substitutions that are used in a proof:

- Multiplications of monads flatten a term of terms to a single term. If substitutions of terms-for-variables are used in a proof, then they implicitly assume the monad multiplication axioms, hence the result holds for distributive laws between full monads only.
- Variable-for-variable substitutions do not interact with the multiplications of monads, but they are involved in both naturality and unit axioms of distributive laws.

Theorem 5.20 is a direct translation of Plotkin’s original proof, and so this result should hold for pointed endofunctors as well. We see that indeed the only substitutions required in the proof of Theorem 5.20 are variable-for-variable substitutions¹. Similarly, Theorems 5.25 and 5.28 only require variable-for-variable substitutions. Therefore, these theorems preclude the existence of distributive laws for pointed endofunctors as well, generalising Klin and Salamanca’s Theorem 2.4 [35].

¹Note that the ‘trivial’ term-for-variable substitution $x[t/x]$ is still allowed to appear, since this case is covered by the unit axioms rather than the multiplication axioms of distributive laws.

The unit axioms of a distributive law are used every time we change the interpretation of a term t from $x[t/x]$ to $t[x_i/x_i]$, or that of a term s from $s[x_i/x_i]$ to $x[s/x]$. This change in interpretation is implicitly applied when we reduce part of a non-separated term to a variable, and then conclude that the resulting term is separated. This step is used in every proof in this thesis, and so all of them are restricted to pointed endofunctors at minimum.

7.4 Regarding the Necessity of Reducing Terms to Variables in Proofs of No-Go Theorems

The proofs in Chapter 5 have one important thing in common: in all of them, we reduce a non-separated term to either a variable or a constant, gaining a separated term. We now consider this vital step in more detail.

Our main proof strategy to prove that no composite theory of theories \mathbb{T} after \mathbb{S} exists is briefly summarised as follows:

1. Assume by way of a contradiction that a composite theory \mathbb{U} of \mathbb{T} after \mathbb{S} exists.
2. Start with a non-separated term $s[t_y/y]$.
3. By the separation axiom of composite theories, this term is equal to some separated term: $s[t_y/y] =_{\mathbb{U}} t'[s'_x/x]$.
4. Manipulate $s[t_y/y]$ into a separated term using substitutions, while also applying these substitutions to $t'[s'_x/x]$.
5. Apply essential uniqueness to the resulting equality of two separated terms. This will yield some useful information about the term $t'[s'_x/x]$.
6. Repeat until a contradiction is derived.

In the fourth step of this plan, we need to transform the term $s[t_y/y]$ into a separated term, using only equational logic and the axioms of \mathbb{S} and \mathbb{T} .

One way to achieve this goal is to reduce either the term s or each of the t_y to a variable, using a substitution f :

$$\begin{aligned} s[t_y/y][f] &=_{\mathbb{U}} y[t_y/y], \\ \text{or } s[t_y/y][f] &=_{\mathbb{U}} s[x_i/y_i]. \end{aligned}$$

Both $y[t_y/y]$ and $s[x_i/y_i]$ are separated terms.

Another way is to prove the term $s[t_y/y]$ (under some substitution f) equal to a constant of one of the component theories:

$$\begin{aligned} s[t_y/y][f] &=_{\mathbb{U}} e_{\mathbb{S}}, \\ \text{or } s[t_y/y][f] &=_{\mathbb{U}} e_{\mathbb{T}}. \end{aligned}$$

Both $e_{\mathbb{S}}$ (a constant in \mathbb{S}) and $e_{\mathbb{T}}$ (a constant in \mathbb{T}) are separated terms.

All our proofs use one or both of these methods to complete this fourth step in the proof plan. An important question remains:

Is the reduction of a term to a variable or constant a crucial step in a no-go proof for distributive laws?

That is, are there no-go theorems that avoid this step in their proof? Can a non-separated term be separated using only the axioms of \mathbb{S} and \mathbb{T} without reducing a term to variable or constant? Are there no-go theorems that use a completely different strategy altogether? The answers to these questions are unknown at present.

7.4.1 Conjectures

Relying on the experience I have gained during my time as a DPhil student, I would like to share the following thoughts on the matter:

- A proof by contradiction seems the most obvious tactic for proving a no-go theorem, but it is not necessarily the only possible one.
- In a proof by contradiction, the only knowledge we can work with is provided by the axioms of composite theories, separation and essential uniqueness, and the axioms of the two theories \mathbb{S} and \mathbb{T} . A good strategy would therefore start with a term or terms to which we can apply either separation or essential uniqueness. Starting with a manipulation by applying axioms from \mathbb{S} or \mathbb{T} would be less useful, as we then could equally well start the proof with the term resulting from these manipulations.
 - Our method chooses to apply separation first. After applying separation, the only option left seems to be working towards a situation in which we can apply essential uniqueness, which is exactly what our method does.

- A different approach could be to choose two separated terms that are known to be equal in the composite theory, starting the proof with an application of essential uniqueness. However, the two starting terms need to form a non-trivial equation to allow any meaningful conclusions to be derived from them. Without the use of the separation axiom before the application of essential uniqueness, it might not be possible to arrive at such a non-trivial equation.

In conclusion, I think that our current method is by far the most obvious one, but not necessarily the only method for proving no-go theorems of this kind. For our method, I believe that reduction to a variable or constant is indeed a crucial step. Whether it is a crucial step in *all* no-go theorem proofs, I cannot say. If it were, this would imply that there is always a distributive law for two monads presented by theories in which such reductions are impossible. While this would be a powerful discovery, the current knowledge about the existence of distributive laws is too sparse to make an accurate prediction. Since all currently-known examples of non-existing distributive laws involve monads with either units or idempotence equations, it is my hope that these are the only cases in which distributive laws fail to exist. I will therefore conjecture this, to give others the motivation to prove my conjecture, or to prove me wrong. I am looking forward to either.

Conjecture 1. *Any theorem that proves the non-existence of a distributive law will involve at least one monad that is presented by an algebraic theory \mathbb{S} for which the following axiom holds:*

- \mathbb{S} has an n -ary term s ($n \geq 2$), for which there is a substitution $f : \text{var}(s) \rightarrow \mathbb{S}$ such that for any $x \in \text{var}(s)$:

$$\Gamma \vdash s[f(y)/y \neq x] =_{\mathbb{S}} x.$$

Chapter 8

Conclusion

In this thesis we have adopted an algebraic perspective on monads, using *composite theories* to study compositions of monads via distributive laws. This led us to discover a new and powerful method to prove no-go theorems for distributive laws, showing that certain monads cannot be composed in this way.

The key observation in this work is that the implications (\Rightarrow) in the original definition of composite theories are in fact bi-implications (\Leftrightarrow), which is a vital property in many of our proofs.

Using our method, we proved several no-go theorems, which together cover a large class of monads. Many of our no-go theorems are direct generalisations of concrete counterexamples, some of which were previously known, such as Counterexample 5.18. Others, such as Counterexample 5.9, are new.

Perhaps the most surprising theorem is Theorem 5.4, which rules out distributive laws between monads if one of them is presented by a theory that has more than one constant, and a few other conditions are met. The proof of this theorem is relatively simple, yet its implications are far-reaching: any composite monad falls within its scope if it comes from two structures that each have a constant (and some other niceness properties apply).

We have given various examples of monads that are shown not to compose via a distributive law by our theorems, including a large overview of such monads that are part of the Boom hierarchy. A few noteworthy examples of monads that are shown not to compose via a distributive law are:

- The Abelian group monad (A) and the list monad (L): There is no distributive law $A \circ L \Rightarrow L \circ A$. This finally answers the open question Beck posed in his original paper on distributive laws in 1969 [5].

- The list monad (L) with itself: There is no distributive law $L \circ L \Rightarrow L \circ L$. This has been an open question posed by Manes and Mulry in 2007 [44, 45].
- The list monad (L) and the exception monad ($- + E$): There is no distributive law $L(- + E) \circ \Rightarrow (- + E) \circ L$. Manes and Mulry erroneously claimed to have found a distributive law of this type [45].
- Any iterated composition of the multiset monad (M). There is no distributive law $(M \circ M) \circ M \Rightarrow M \circ (M \circ M)$ nor is there a distributive law $M \circ (M \circ M) \Rightarrow (M \circ M) \circ M$. This is slightly surprising, as the multiset monad is otherwise very well behaved.

In addition to this main line of research, we have studied a few extreme cases of distributive laws: the identity natural transformation $Id : TT \Rightarrow TT$, and the natural transformations $T\eta \circ \mu : TT \Rightarrow TT$ and $\eta T \circ \mu : TT \Rightarrow TT$. We showed that these natural transformations are distributive laws of type $TT \Rightarrow TT$ if and only if the monad T is idempotent. We hence found three new characterisations of idempotent monads, deepening our understanding of this class of monads.

Coming back to our no-go theorems, we compared the techniques we use in our algebraic approach to common techniques used in categorical proofs. While most observations are unsurprising, the comparison highlighted the difference between substitutions of *variables* for variables and *terms* for variables. Algebraically, these are considered the same and they are captured by a single axiom. Categorically, however, a substitution of variables for variables corresponds to just an application of the monad to the substitution function, while a substitution of terms for variables requires the Kleisli extension of that function. The difference between the two types of substitutions also affects the scope of the theorems: a proof using just variables-for-variables substitutions holds for pointed endofunctors as well as monads, whereas a proof using a terms-for-variables substitution is only valid for monads.

The main advantage of using composite theories is that they allow for manipulations on the term level, whereas traditional categorical methods that work directly with distributive laws only reach equivalence classes. Equivalence classes can be fiddly to work with, allowing small things to be overlooked, as evidenced for example by the faulty distributive law for the powerset monad over itself in the *Handbook of Algebra* [43, pages 78-79]. At term level, functions and variables are much more straightforward to manipulate, reducing the risk of errors.

Using universal algebra rather than category theory has also shown us which axioms we use, and when we use them. This allowed us to gain a deeper understanding

of the mechanics of our proofs, pinpointing exactly which properties and steps in the proofs are essential. The main conclusion we were able to draw from this analysis was that all our proofs require a way to reduce a term to a variable. Our overview of the extended Boom hierarchy illustrates this point beautifully: monads in this hierarchy need to have either an idempotent term or a unital term for our theorems to apply. It is currently not known if the reduction of a term to a variable is a crucial step in *every* possible no-go theorem. We conjectured that this is indeed the case, and we see this question as the most important remaining open question about monad compositions via distributive laws on the category **Set**.

This brings us to another limitation of our method: the fact that it is restricted to monads on the category **Set**. In **Set**, we have a one-to-one correspondence between finitary monads and algebraic theories, which is replaced by a correspondence between monads and *Lawvere* theories for monads on other categories. There is a concept of a composite Lawvere theory, due to Cheng [12], which could open a way for our method to generalise beyond **Set**. However, our method is based on explicit term manipulations, which is not possible in Lawvere theories in general. We therefore propose to find concrete presentations for these monads/Lawvere theories. There is some work in this direction [17–24, 33, 54], resulting in interesting and exotic algebraic theories, where terms may only be well-formed if their variables and operations obey some order relations. We need a better understanding of these exotic theories before we can apply our methods beyond **Set**, so we recommend this as a direction for future work.

Appendix A

Notation

X, Y, Z	sets
a, b, c, d	variables
x, y, z	variables
Γ	a set of variables
F, G	functors
S, T	monads
\mathbb{S}, \mathbb{T}	algebraic theories
\mathbb{U}	a composite algebraic theory
s, t, u	terms in an algebraic theory
\vdash	indicating variable context
$t[s_x/x]$	a substitution of terms s_x for the variables x
$t[f]$	a substitution according to the function f
$[t]_{\mathbb{T}}$	an equivalence class of terms in theory \mathbb{T} with representative t
$\llbracket \cdot \rrbracket^a$	interpretation function based on algebra a
$f : X \rightarrow Y$	a function from X to Y
$\phi : F \Rightarrow G$	a natural transformation from F to G
$\#$	concatenation of lists

Appendix B

Proofs

Theorem B.1. *Let \mathbb{S} and \mathbb{T} be two algebraic theories. If there are terms:*

$$n \vdash_{\mathbb{S}} s \quad \text{and} \quad m \vdash_{\mathbb{T}} t,$$

such that:

(S1) *s is idempotent:*

$$\{a\} \vdash s[a/x_i] =_{\mathbb{S}} a.$$

(S2) *For all terms $s' \in \mathbb{S}$, and each variable a:*

$$\Gamma \vdash a =_{\mathbb{S}} s' \quad \Rightarrow \quad \{a\} \vdash s'.$$

(S3) *For all terms $s' \in \mathbb{S}$:*

$$\Gamma \vdash s =_{\mathbb{S}} s' \quad \Rightarrow \quad \neg \left(\bigvee_{x_i \in \Gamma} \{x_i\} \vdash s' \right).$$

(T1) *t is stable under a fixed-point free permutation σ :*

$$m \vdash t =_{\mathbb{T}} t[\sigma(x)/x].$$

(T2) *t has a substitution $f_t : \text{var}(t) \rightarrow \mathbb{T}$ such that for any $x_i \in \text{var}(t)$:*

$$\Gamma \vdash t[f_t(x)/x \neq x_i] =_{\mathbb{T}} x_i.$$

(T3) *For all terms $t' \in \mathbb{T}$:*

$$\Gamma \vdash t =_{\mathbb{T}} t' \quad \Rightarrow \quad m \vdash t'.$$

Then there is no composite theory of \mathbb{T} after \mathbb{S} .

Proof. Assume by way of a contradiction that a composite theory \mathbb{U} of \mathbb{T} after \mathbb{S} exists. Let a_i^j denote distinct variables, where $1 \leq i \leq m$ and $1 \leq j \leq n$. We consider the term

$$s(t(a_1^1, \dots, a_m^1), \dots, t(a_1^n, \dots, a_m^n)).$$

Then as \mathbb{U} is composite, the separation axiom of composite theories tells us that there exist $X \vdash t'$ and $\Gamma \vdash s'_x$ for each $x \in X$ such that:

$$s(t(a_1^1, \dots, a_m^1), \dots, t(a_1^n, \dots, a_m^n)) =_{\mathbb{U}} t'[s'_x/x].$$

We use the same approach as in the proof of Theorem 5.25, using substitutions to bound the variables that can appear in each of the s'_x . Define substitution f_1 as follows:

$$f_1(a_i^j) = a_i^1.$$

We then have:

$$s(t(a_1^1, \dots, a_m^1), \dots, t(a_1^1, \dots, a_m^1)) =_{\mathbb{U}} t'[s'_x[f_1]/x].$$

By assumption (S1), idempotence of s :

$$t(a_1^1, \dots, a_m^1) =_{\mathbb{U}} t'[s'_x[f_1]/x].$$

We have two separated terms that are equal to each other, so essential uniqueness tells us that there are substitutions g_1 and g_2 such that:

$$t[g_1] =_{\mathbb{T}} t'[g_2] \quad (\text{Proposition 3.4, 3a})$$

$$g_1(a_i^1) \neq g_1(a_j^1) (i \neq j) \quad (\text{Proposition 3.4, 3b})$$

$$g_1(a_i^1) = g_2(x) \Leftrightarrow a_i^1 =_{\mathbb{S}} s'_x[f_1], \quad (\text{Proposition 3.4, 3d})$$

and (T3) gives us that:

$$\forall x \exists i : a_i^1 =_{\mathbb{S}} s'_x[f_1]. \quad (\text{B.1})$$

Then by assumption (S2):

$$\forall x \exists i : \{a_i^1\} \vdash s'_x[f_1].$$

So our first approximation of the variables appearing in s'_x is:

$$\forall x \exists i : \{a_i^1, \dots, a_i^n\} \vdash s'_x. \quad (\text{B.2})$$

Now we define a family of substitutions for $2 \leq k \leq n$ as follows:

$$f_k(a_i^j) = \begin{cases} a_{\sigma(i)}^k & \text{if } j = k \\ a_i^k & \text{otherwise.} \end{cases}$$

If we follow a similar argument as before, using essential uniqueness, (T3), (S2), and also exploiting assumption (T1), we conclude that:

$$\forall x, k \exists i_k : \{a_{i_k}^k\} \vdash s'_x[f_k].$$

And so:

$$\forall x, k \exists i_k : \{a_{\sigma^{-1}(i_k)}^j \mid j = k\} \cup \{a_{i_k}^j \mid j \neq k\} \vdash s'_x. \quad (\text{B.3})$$

Using Lemma 5.24, Equations (B.2) and (B.3), we conclude that for all x , s'_x can only contain a single variable:

$$\forall x \exists i, j : \{a_i^j\} \vdash s'_x. \quad (\text{B.4})$$

This implies that for each x , s'_x is equal to a variable:

- If for some i , $a_i^1 \vdash s'_x$, then $s'_x[f_1] = s'_x$. From Equation (B.1) we know that there is an i' such that $s'_x[f_1] =_{\mathbb{S}} a_{i'}^1$, and so also $s'_x =_{\mathbb{S}} a_{i'}^1$. Hence s'_x is equal to a variable.
- Otherwise, there is a $j \neq 1$ and an i such that $a_i^j \vdash s'_x$. In this case $s'_x[f_1][a_{i'}^j/a_{i'}^1] = s'_x$. From Equation (B.1) we know that there is an i'' such that $s'_x[f_1] =_{\mathbb{S}} a_{i''}^1$, and so by substitution there is an i'' such that $s'_x[f_1][a_{i'}^j/a_{i'}^1] =_{\mathbb{S}} a_{i''}^1[a_{i'}^j/a_{i'}^1] = a_{i''}^j$. Therefore also $s'_x = a_{i''}^j$, proving that s'_x is indeed equal to a variable.

To finish the argument, we define another substitution, using the substitution f_t from property (T2):

$$f_{n+1}(a_i^j) = \begin{cases} a_i^j, & \text{if } i = 1 \\ f_t(a_i^j), & \text{otherwise.} \end{cases}$$

Applying this substitution:

$$\begin{aligned} & s(t(a_1^1, f_t(a_2^1), \dots, f_t(a_m^1)), \dots, t(a_1^n, f_t(a_2^n) \dots, f_t(a_m^n))) =_{\mathbb{U}} t'[s'_x[f_{n+1}]/x] \\ \Rightarrow & \{ \text{property (T2)} \} \\ & s(a_1^1, \dots, a_1^n) =_{\mathbb{U}} t'[s'_x[f_{n+1}]/x]. \\ \Rightarrow & \{ \text{clarifying that } s \text{ is a separated term} \} \\ & y[s(a_1^1, \dots, a_1^n)/y] =_{\mathbb{U}} t'[s'_x[f_{n+1}]/x]. \end{aligned}$$

Notice that the term $t'[s'_x[f_{n+1}]/x]$ is still separated: since every s'_x is just a variable, the substitution f_{n+1} does not break separation, even though it might insert a \mathbb{T} term.

We can hence apply essential uniqueness. This gives us that there are substitutions $g_1 : \{y\} \rightarrow Z, g_2 : X \rightarrow Z$ such that:

$$\begin{aligned} y[g_1] &=_{\mathbb{T}} t'[g_2] \\ g_1(y) = g_2(x) &\Leftrightarrow s(a_1^1, \dots, a_1^n) =_{\mathbb{S}} s'_x. \end{aligned}$$

By consistency of \mathbb{T} , we know that there is at least one x such that $g_1(y) = g_2(x)$. And hence there is at least one s'_x such that $s'_x =_{\mathbb{S}} s(a_1^1, \dots, a_1^n)$. But this contradicts assumption (S3), since for all x , s'_x is equal to a variable. We conclude that no composite theory of \mathbb{T} after \mathbb{S} can exist. \square

References

- [1] S. Awody: *Category Theory*. Oxford University Press, 2010.
- [2] D. Ashoush and B. Coecke: *Dual Density Operators and Natural Language Meaning*. In: *Electronic Proceedings in Theoretical Computer Science*, vol. 221, pp. 1–10, 2016. doi: 10.4204/EPTCS.221.1.
- [3] J. Baez and M. Stay: *Physics, topology, logic and computation: a Rosetta Stone*. In: *New structures for physics*, Springer Berlin Heidelberg, pp. 95–172, 2010.
- [4] M. Barr and C. Wells: *Category theory for computing science*. Prentice Hall New York, 1990.
- [5] J. Beck: *Distributive Laws*. In: *Seminar on Triples and Categorical Homotopy Theory*, Springer Berlin Heidelberg, pp. 119-140, 1969.
- [6] R. S. Bird: *Lectures on Constructive Functional Programming*. In: *Constructive Methods in Computing Science*. NATO ASI Series (Series F: Computer and Systems Sciences), vol. 55, Springer Berlin Heidelberg, 1989. doi: 10.1007/978-3-642-74884-4_5
- [7] M. M. Bonsangue, H. H. Hansen, A. Kurz, and J. Rot: *Presenting Distributive Laws*. In: *International Conference on Algebra and Coalgebra in Computer Science*, Springer Berlin Heidelberg, pp. 95–109, 2013.
- [8] H. J. Boom: *Further Thoughts on Abstracto*. WG 2.1 working paper, ELC-9, unpublished, 1981.
- [9] F. Borceux: *Handbook of Categorical Algebra: Volume 2, Categories and Structures*. Cambridge University Press, 1994.
- [10] Youtube Channel: <https://www.youtube.com/user/TheCatsters/>

- [11] E. Cheng: *Iterated distributive laws*. In: Mathematical Proceedings of the Cambridge Philosophical Society, vol. 150, no. 3, pp. 459–487, 2011.
- [12] E. Cheng: *Distributive laws for Lawvere theories*. In: Compositionality, vol. 2, no. 1, 2020. doi: 10.32408/compositionality-2-1.
- [13] K. Claessen and J. Hughes: *QuickCheck: A Lightweight Tool for Random Testing of Haskell Programs*. In: ACM Sigplan Notices, vol. 46, no. 4, pp. 53–64, 2000.
- [14] B. Coecke, M. Sadrzadeh, and N. Clark: *Mathematical Foundations for a Compositional Distributional Model of Meaning*. In: Linguistic Analysis, vol. 36, pp. 345–384, 2011.
- [15] F. Dahlqvist, L. Parlant, and A. Silva: *Layer by layer - Combining Monads*. In: Proceedings of the International Colloquium on Theoretical Aspects of Computing (ICTAC2018), pp. 153-172, 2018. doi: 10.1007/978-3-030-02508-3_9.
- [16] F. Dahlqvist and R. Neves: *Compositional semantics for new paradigms: Probabilistic, hybrid and beyond*. arXiv:1804.04145 [cs.LO], 2018.
- [17] M. Fiore: *Second-order and dependently-sorted abstract syntax*. In: 23rd Annual IEEE Symposium on Logic in Computer Science (LiCS2008), pp. 57–68, 2008.
- [18] M. Fiore and C. K. Hur: *Term equational systems and logics*. In: Electronic Notes in Theoretical Computer Science, vol. 218, pp. 171–192, 2008.
- [19] M. Fiore and C. K. Hur: *On the construction of free algebras for equational systems*. In: Theoretical Computer Science, vol. 410, no. 18, pp. 1704–1729, 2009.
- [20] M. Fiore and C. K. Hur: *Second-order equational logic*. In: International Workshop on Computer Science Logic (CSL2010), pp. 320–335, 2010.
- [21] M. Fiore and C. K. Hur: *On the mathematical synthesis of equational logics*. In: arXiv:1107.3031 [cs.LO].
- [22] M. Fiore: *An equational metalogic for monadic equational systems*. In: Theory and Applications of Categories, vol. 27, no. 18, pp. 464–492, 2013.
- [23] R. Gordon and A. J. Power: *Enrichment through variation*. In: Journal of Pure and Applied Algebra, vol. 120, no. 2, pp. 167–185, 1997.

- [24] R. Gordon and A. Power: *Algebraic structure for bicategory enriched categories*. In: Journal of Pure and Applied Algebra, vol. 130, no. 2, pp. 119–132, 1998.
- [25] A. Hatcher: *Algebraic Topology*. Cambridge University Press, 2002.
- [26] R. Hinze and D. Marsden: *Dragging Proofs Out of Pictures*. In: A List of Successes That Can Change the World: Essays Dedicated to Philip Wadler on the Occasion of His 60th Birthday, pp. 152–168, 2016. doi: 10.1007/978-3-319-30936-1_8.
- [27] P. Hudak, S. Peyton Jones, P. Wadler, B. Boutel, J. Fairbairn, J. Fasel, M. M. Guzmán, K. Hammond, J. Hughes, T. Johnsson, and others: *Report on the programming language Haskell: a non-strict, purely functional language version 1.2*. In: ACM SigPlan notices, vol. 27, no. 5, pp. 1–164, 1992.
- [28] M. Hyland, G. Plotkin, and J. Power: *Combining effects: Sum and tensor*. In: Theoretical Computer Science, vol. 357, no. 1, pp. 70–99”, 2006. doi: 10.1016/j.tcs.2006.03.013.
- [29] B. Jacobs: *Semantics of weakening and contraction*. In: Annals of Pure and Applied Logic, vol. 69, pp. 73–106, 1994.
- [30] B. Jacobs: *Convexity, duality and effects*. In: Proceedings of the IFIP International Conference on Theoretical Computer Science (TCS2010), pp. 1–19, 2010.
- [31] P.T. Johnstone: *Stone Spaces*. Cambridge university press, 1982.
- [32] M. P. Jones and L. Duponcheel: *Composing monads*. Technical Report YALEU/DCS/RR-1004, Department of Computer Science, Yale. 1993.
- [33] G. M. Kelly and A. J. Power: *Adjunctions whose counits are coequalizers, and presentations of finitary enriched monads*. In: Journal of pure and applied algebra, vol. 89, no. 1-2, pp. 163–179, 1993.
- [34] D. J. King and P. Wadler: *Combining monads*. In: Functional Programming, Glasgow 1992, Springer London, pp. 134–143, 1993.
- [35] B. Klin and J. Salamanca: *Iterated covariant powerset is not a monad*. In: Proceedings of the 34th Conference on the Mathematical Foundations of Programming Semantics (MFPS2018), 2018.

- [36] A. Kock: *Monads on symmetric monoidal closed categories*. In: Archiv der Mathematik, vol. 21, no. 1, pp. 1–10, 1970.
- [37] S. Lack: *Composing props*. In: Theory and Applications of Categories, vol. 13, no. 9, pp. 147–163, 2004.
- [38] F. W. Lawvere: *Functorial Semantics of Algebraic Theories*. In: Proceedings of the National Academy of Sciences of the United States of America, vol. 50, no. 5, pp. 869–872, 1963.
- [39] M. Lenisa, J. Power, and H. Watanabe: *Distributivity for endofunctors, pointed and co-pointed endofunctors, monads and comonads*. In: Electronic Notes in Theoretical Computer Science, vol. 33, pp. 230–260, 2000.
- [40] F. E. J. Linton: *Some aspects of equational categories*. In: Proceedings of the Conference on Categorical Algebra, pp. 84–94, 1966.
- [41] S. Mac Lane: *Categories for the working mathematician*. Springer Science & Business Media, 2013.
- [42] E. Manes: *Algebraic theories*. Springer Science & Business Media, 2012.
- [43] E. Manes: *Monads of sets*. In: Handbook of algebra, Elsevier Amsterdam, vol. 3, pp. 67–153, 2003.
- [44] E. Manes and P. Mulry: *Monad compositions I: general constructions and recursive distributive laws*. In: Theory and Applications of Categories, vol. 18, pp. 172–208, 2007.
- [45] E. Manes and P. Mulry: *Monad compositions II: Kleisli strength*. In: Mathematical Structures in Computer Science, vol. 18, no. 3, pp. 613–643, 2008. doi: 10.1017/S0960129508006695.
- [46] Mathematics Genealogy Project: <https://genealogy.math.ndsu.nodak.edu/>
- [47] D. Marsden: *Ambiguity and Incomplete Information in Categorical Models of Language*. In: Proceedings of the 13th International Conference on Quantum Physics and Logic (QPL2016), EPTCS vol. 236, pp. 95–107, 2017. doi: 10.4204/EPTCS.236.7.

- [48] L. Meertens: *Algorithmics, towards programming as a mathematical activity*. In: Mathematics and Computer Science: Proceedings of the CWI Symposium, November 1983, pp. 289-334, 1986.
- [49] E. Moggi: *Notions of computation and monads*. In: Information and Computation, Selections from 1989 IEEE Symposium on Logic in Computer Science, vol. 93, no. 1, pp. 55–92, 1991. doi: 10.1016/0890-5401(91)90052-4.
- [50] P. Panangaden, private communication, 2018.
- [51] S. Peyton Jones: *Tackling the Awkward Squad: monadic input/output, concurrency, exceptions, and foreign-language calls in Haskell*. In: Engineering Theories of Software Construction, IOS press, pp. 47–96, 2001.
- [52] M. Piróg and S. Staton: *Backtracking with cut via a distributive law and left-zero monoids*. In: Journal of Functional Programming, vol. 27, 2017.
- [53] G. Plotkin and J. Power: *Notions of computation determine monads*. In: Proceedings of the International Conference on Foundations of Software Science and Computation Structures (FOSSACS2002), pp. 342–356, 2002.
- [54] E. Robinson: *Variations on algebra: Monadicity and generalisations of equational theories*. In: Formal Aspects of Computing, vol. 13, no. 3-5, pp. 308–326, 2002.
- [55] J. Salamanca, private communication, 2018.
- [56] P. Selinger: *A Survey of Graphical Languages for Monoidal Categories*. In: New Structures for Physics, Springer Berlin Heidelberg, pp. 289-355, 2011. doi: 10.1007/978-3-642-12821-9_4.
- [57] S. Spackman, private communication, 2019.
- [58] M. H. Stone: *Postulates for the barycentric calculus*. In: Annali di Matematica Pura ed Applicata, vol. 29, no. 1, pp. 25–30, 1949.
- [59] T. Uustalu: *A divertimento on MonadPlus and nondeterminism*. In: Journal of Logical and Algebraic Methods in Programming, vol. 85, no. 5 part 2, pp. 1086–1094, 2016. doi: 10.1016/j.jlamp.2016.06.004.
- [60] D. Varacca and G. Winskel: *Distributing probability over non-determinism*. In: Mathematical Structures in Computer Science, vol. 16, no. 1, pp. 87–113, 2006.

- [61] D. Varacca: *Probability, Nondeterminism and Concurrency: Two Denotational Models for Probabilistic Computation*. PhD Thesis at BRICS, Department of Computer Science, University of Aarhus, 2003.
- [62] P. Wadler: *Monads for functional programming*. In: *Advanced Functional Programming*, Springer Berlin Heidelberg, pp. 24–52, 1995.
- [63] F. Zanasi: *Interacting Hopf Algebras, the theory of linear systems*. PhD thesis at Laboratoire de l'Informatique du Parallélisme, École Doctorale en Informatique et Mathématiques de Lyon, Université de Lyon, 2015.
- [64] M. Zwart and B. Coecke: *Double dilation \neq double mixing*. In: *Proceedings of the 14th International Conference on Quantum Physics and Logic (QPL2017)*, 2017.